



### QUICK SELECTION / Selezione veloce

input speed ( $n_1$ ) = 1400 min<sup>-1</sup>

Output Speed $n_2$ [min <sup>-1</sup> ]	Ratio $i$	Motor power $P_{1M}$ [kW]	Output torque $M_{2M}$ [Nm]	Service factor f.s.	Nominal power $P_{1R}$ [kW]	Nominal torque $M_{2R}$ [Nm]	Available B5 motor flanges		Available B14 motor flanges			Output Shaft 	Ratios code		
							-B	-C	-O	-P	-Q				
891	<b>1.57</b>	0.37	4	3.3	1.2	13			C	C		2844	standard ø14	01	
493	<b>2.84</b>	0.37	7	3.3	1.2	23			C	C		1954		02	
425	<b>3.29</b>	0.37	8	3.2	1.2	26			C	C		1756		03	
362	<b>3.87</b>	0.37	10	2.9	1.1	28			C	C		1558		04	
303	<b>4.62</b>	0.37	11	2.6	0.97	30			C	C		1360		On request	05
222	<b>6.30</b>	0.37	16	2.2	0.83	35			C	C		1063		ø19	06
170	<b>8.22</b>	0.37	20	1.9	0.69	38			C	C		974		ø24	07
129	<b>10.86</b>	0.37	27	1.0	0.39	28			C	C		776			08

The dynamic efficiency is **0.98** for all ratios

**A) Motor Flanges Available**  
Flange Motore Disponibili

**B) Supplied with Reduction Bushing**  
Fornito con Bussola di Riduzione

**B) Available on Request without reduction bushing**  
Disponibile a Richiesta senza Bussola di Riduzione

**C) Motor Flange Holes Position**  
Posizione Fori Flangia Motore

**EN** Unit **311A** is supplied with synthetic oil for lifetime lubrication, no maintenance is necessary. See table 1 for lubrication and recommended quantity. In table 2 please see possible radial loads and axial loads on the gearbox.

**I** Il riduttore **311A** viene fornito completo di olio sintetico per la lubrificazione permanente e non necessita di alcuna manutenzione. Vedi tab.1 per oli e quantità consigliati. In tab.2 sono presenti i carichi radiali e assiali applicabili al riduttore.

**D** Das Getriebe **311A** ist mit synthetischem Öl gefüllt und ist lebensdauer geschmiert. In Tabelle 1 ist die Schmiermenge und das empfohlene Schmiermittel angegeben. In Tabelle 2 sind die zulässigen Radial - und Axialbelastungen des Getriebes aufgeführt.

**F** Le réducteur **311A** est fourni complet avec de l'huile synthétique pour la lubrification permanente et ne nécessite aucun entretien. Voir tableau 1 concernant les huiles et les quantités conseillées. Les charges radiales et axiales applicables au réducteur sont précisées dans le tableau 2.

**E** El reductor tamaño **311A** se suministra, lubricado de por vida con aceite sintético y no requieren mantenimiento alguna. Ver tabla 1, para cantidades y aceites recomendados. En la tabla 2, se encuentran las cargas radiales y axiales admitidas por el reductor.

### LUBRICATION 311A Oil Quantity 0.10 Lt.

**AGIP** Telium VSF 320

**SHELL** Omala S4 WE 320

For all details on lubrication and plugs check our website

tab. 1

Per maggiori dettagli su lubrificazione e tappi olio vedi il nostro sito web

### RADIAL AND AXIAL LOADS

#### Output shaft

Albero di uscita

$$F_{eq} = F_R \cdot \frac{38.5}{X+18.5}$$

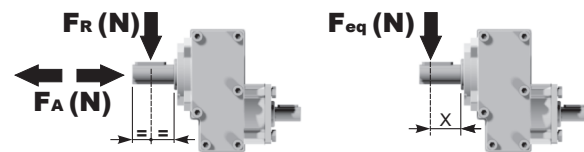

$n_2$	FA	FR	$n_2$	FA	FR	$n_2$	FA	FR
700	120	640	400	160	800	200	200	1020
600	140	700	300	175	880	140	225	1120

#### Input shaft

Albero in entrata

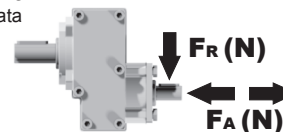

$n_1$	FA	FR
1400	180	860
900	200	980

tab. 2

**P311-F...** Output flange  
flange di uscita

Gearbox weight  
peso riduttore **2.50 kg**

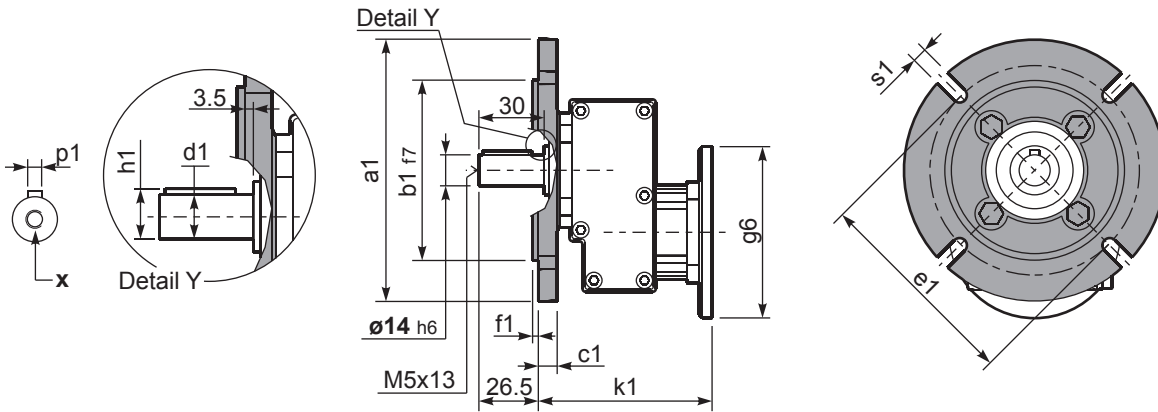

**\*Available output shaft / Alberi di uscita**

	Shaft - d1	p1	h1	x
Standard	∅ 14x30	5	16	M5x13
On request A richiesta	∅ 19x40 ∅ 24x40	6 8	21.5 27	M6x16 M6x16

**Available output flanges / flange di uscita**

a1 ∅	b1	c1	e1	f1	s1	kit code
120	80	11.5	100	3	9*	KC30.9.010
140	95	11.5	115	3	9	KC30.9.011
160	110	11.5	130	3.5	9	KC30.9.012
200	130	11.5	165	3.5	11	KC30.9.013

\*Holes position  
posizione fori



**P311-H1...** With feet  
Con piedini

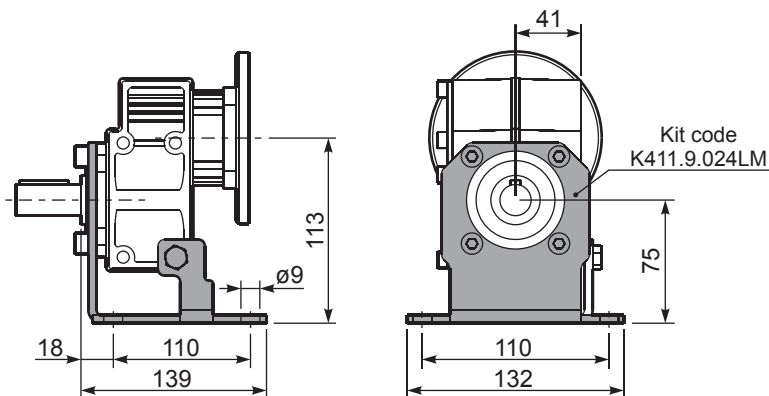

**R311-N...** Input Shaft  
Albero in entrata

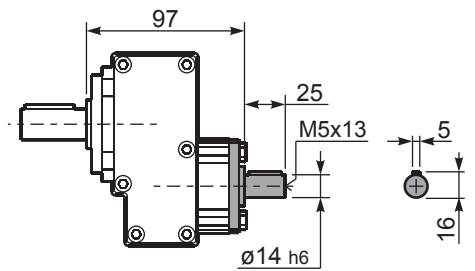

**P311-N...** Basic gearbox  
Riduttore base

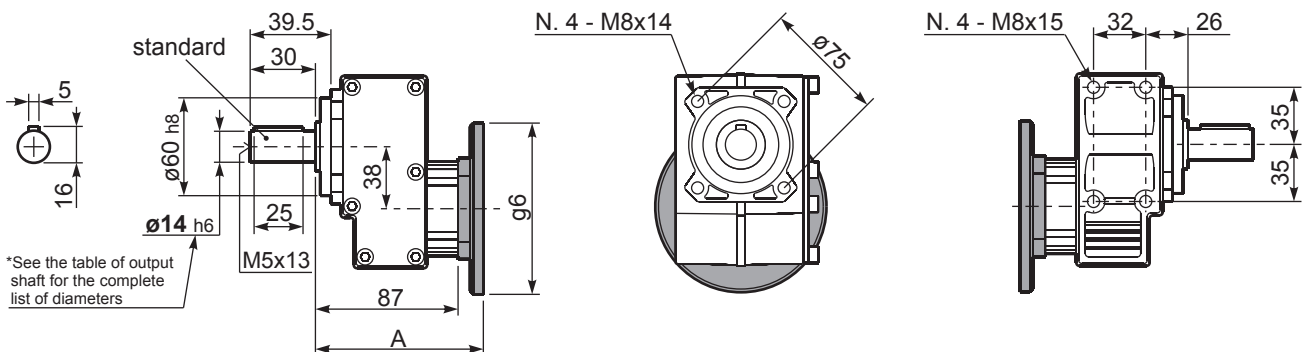

B14 Motor Flanges	A	g6	k1	kit code
56 B14	103	80	106.5	KC40.4.049
63 B14	105.5	90	109	K050.4.047
71 B14	103	105	106.5	K050.4.045

B5 Motor Flanges	A	g6	k1	kit code
63 B5	105.5	138	109	K050.4.041
71 B5	103	160	106.5	K050.4.042