



#### QUICK SELECTION / Selezione veloce

input speed ( $n_1$ ) = 1400 min<sup>-1</sup>

Output Speed $n_2$ [min <sup>-1</sup> ]	Ratio $i$	Motor power $P_{1M}$ [kW]	Output torque $M_{2M}$ [Nm]	Service factor $f.s.$	Nominal power $P_{1R}$ [kW]	Nominal torque $M_{2R}$ [Nm]	Available B5 motor flanges				Available B14 motor flanges			Output Shaft 	Ratios code
							-B	-C	-D	-E	-Q	-R	-T		
							63	71*	80*	90*	71	80	90		
407	<b>3.44</b>	1.5	34	1.0	1.6	35	B				C	C		2821	01
327	<b>4.28</b>	1.5	42	1.0	1.4	40	B				C	C		2818	02
257	<b>5.45</b>	1.5	53	1.0	1.5	52	B				C	C		2815	03
225	<b>6.23</b>	1.5	61	1.1	1.7	70	B				C	C		1921	04
194	<b>7.20</b>	1.5	71	1.0	1.5	70	B				C	C		2812	05
181	<b>7.74</b>	1.5	76	1.1	1.6	80	B				C	C		1918	06
142	<b>9.85</b>	1.5	97	1.0	1.5	95	B				C	C		1915	07
123	<b>11.42</b>	1.5	112	1.0	1.5	115	B				C	C		1715	08
107	<b>13.03</b>	1.1	93	1.2	1.3	114	B				C	C		1912	09
93	<b>15.10</b>	1.1	108	1.1	1.2	114	B				C	C		1712	10
86	<b>16.20</b>	0.75	80	1.3	1.0	107	B				C	C		1910	11
75	<b>18.78</b>	0.75	92	1.2	0.87	107	B				C	C		1710	12
66	<b>21.15</b>	0.75	104	1.1	0.82	114	B				C	C		1312	13
64	<b>21.84</b>	0.75	107	1.1	0.83	119	B				C	C		1015	14
53	<b>26.31</b>	0.55	95	1.1	0.62	107	B				C	C		1310	15
48.5	<b>28.88</b>	0.55	105	1.1	0.60	114	B				C	C		1012	16
39	<b>35.91</b>	0.37	87	1.2	0.46	107	B				C	C		1010	17
37.1	<b>37.69</b>	0.37	91	1.1	0.41	102	B				C	C		912	18
29.9	<b>46.87</b>	0.37	113	0.9	0.35	107	B				C	C		910	19
28.1	<b>49.76</b>	0.25	81	1.2	0.31	101	B				C	C		712	20
22.6	<b>61.89</b>	0.25	101	1.1	0.26	107	B				C	C		710	21

The dynamic efficiency is **0.96** for all ratios

\*Nel montaggio P la flangia può superare l'ingombro massimo dei piedi. Eventualmente utilizzare la flangia B14  
\* In the P mounting the B5 motor flange can exceed the foot maximum dimensions. Possibly use the flange B14

**A) Motor Flanges Available**  
Flange Motore Disponibili

**B) Supplied with Reduction Bushing**  
Fornito con Bussola di Riduzione

**C) Available on Request without reduction bushing**  
Disponibile a Richiesta senza Bussola di Riduzione

**D) Motor Flange Holes Position**  
Posizione Fori Flangia Motore

**EN** Unit **302A** is supplied with synthetic oil for lifetime lubrication, no maintenance is necessary. See table 1 for lubrication and recommended quantity. In table 2 please see possible radial loads and axial loads on the gearbox.

**I** Il riduttore **302A** viene fornito completo di olio sintetico per la lubrificazione permanente e non necessita di alcuna manutenzione. Vedi tab.1 per oli e quantità consigliati. In tab.2 sono presenti i carichi radiali e assiali applicabili al riduttore.

**D** Das Getriebe **302A** ist mit synthetischem Öl gefüllt und ist lebensdauergeschmiert. In Tabelle 1 ist die Schmiermenge und das empfohlene Schmiermittel angegeben. In Tabelle 2 sind die zulässigen Radial - und Axialbelastungen des Getriebes aufgeführt.

**F** Le réducteur **302A** est fourni complet avec de l'huile synthétique pour la lubrification permanente et ne nécessite aucun entretien. Voir tableau 1 concernant les huiles et les quantités conseillées. Les charges radiales et axiales applicables au réducteur sont précisées dans le tableau 2.

**E** El reductor tamaño **302A** se suministra, lubricado de por vida con aceite sintético y no requieren mantenimiento alguna. Ver tabla 1, para cantidades y aceites recomendados. En la tabla 2, se encuentran las cargas radiales y axiales admitidas por el reductor.

#### LUBRICATION 302A Oil Quantity 0.15 Lt.

**AGIP** Telium VSF 320

**SHELL** Omala S4 WE 320

For all details on lubrication and plugs check our website

tab. 1

Per maggiori dettagli su lubrificazione e tappi olio vedi il nostro sito web

#### RADIAL AND AXIAL LOADS

##### Output shaft

Albero di uscita

$$F_{eq} = FR \cdot \frac{35.7}{X+20.7}$$

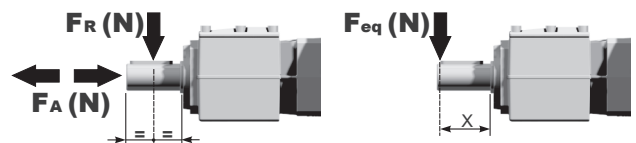

$n_2$	FA	FR	$n_2$	FA	FR	$n_2$	FA	FR
300	140	700	140	246	1320	70	340	1700
250	151	756	120	270	1350	40	380	1900
200	185	924	85	300	1500	15	-	-

##### Input shaft

Albero in entrata

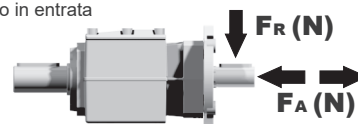

$n_1$	FA	FR
1400	226	1130
900	264	1320
500	322	1610

tab. 2

Gearbox weight **3.5 kg**  
 With flange  
 peso riduttore **4.0 Kg**  
 With feet

P302A **B1**...  
 With feet  
 Con piedini

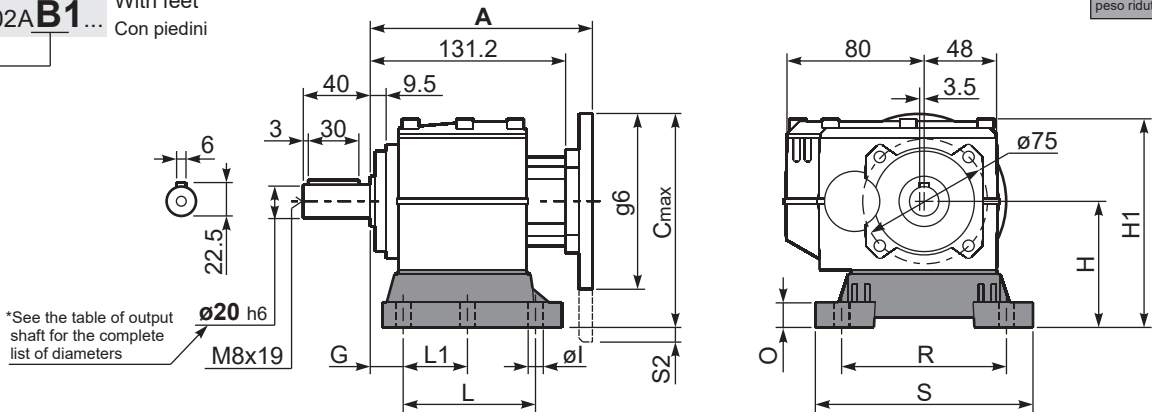

\*See the table of output shaft for the complete list of diameters

Feet Code	Market reference	G	H	R	L	L1	S	H1	O	ø1	S2 only with motor flange	B5 max. Flange	kit code
B1	112	18	85	110	87	50	130	133	15	9	15 80/90B5	-	KC30.9.022
B2	212/3	18	100	130	107.5	60	155	145	5	11	3.5 80/90B5	-	KC30.9.023LM
S1	17-32	18	75	110	110	50	130	123	15	9	5 71B5	71B5	KC30.9.024

Other feet are available, see our web site  
 Sono disponibili altri piedini, consulta il nostro sito web

A see on page bottom

Most popular types  
 Tipi più diffusi

P302A-**F**...  
 Output flanges  
 flange di uscita

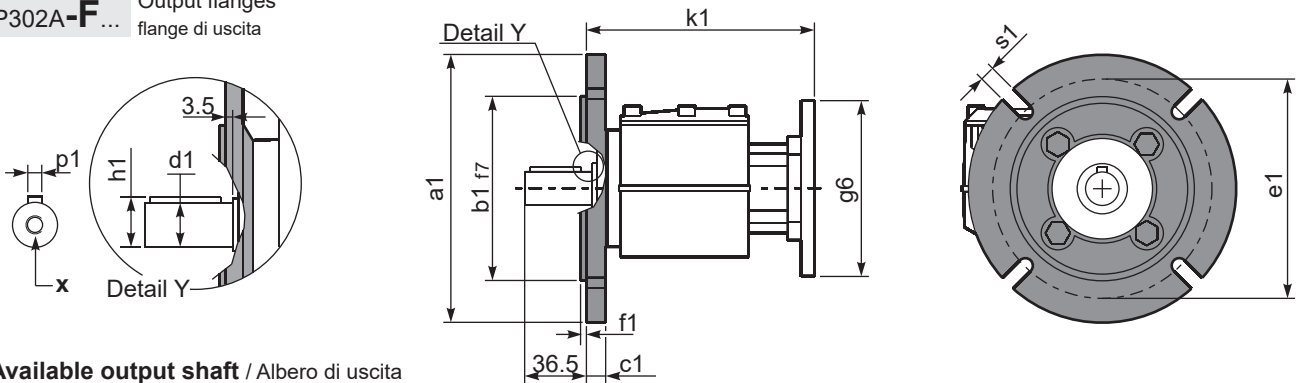

\*Available output shaft / Albero di uscita

	Shaft - d1	p1	h1	x
Standard	ø 20x40	6	22.5	M8x19
On request A richiesta	ø 14x30	5	16	M6x16
	ø 16x40	5	18	M6x16
	ø 19x40	6	21.5	M6x16
	ø 24x50	8	27	M8x19
	ø 25x50	8	28	M8x19

Available output flanges / flange di uscita

a1 ø	b1	c1	e1	f1	s1	kit code
120	80	11.5	100	3	9*	KC30.9.010
140	95	11.5	115	3	9	KC30.9.011
160	110	11.5	130	3.5	9	KC30.9.012
200	130	11.5	165	3.5	11	KC30.9.013

\* Holes position  
 Posizione fori

With flange and feet only on request. Ask for compatibility

P302A-**N**...  
 Basic gearbox  
 Riduttore base

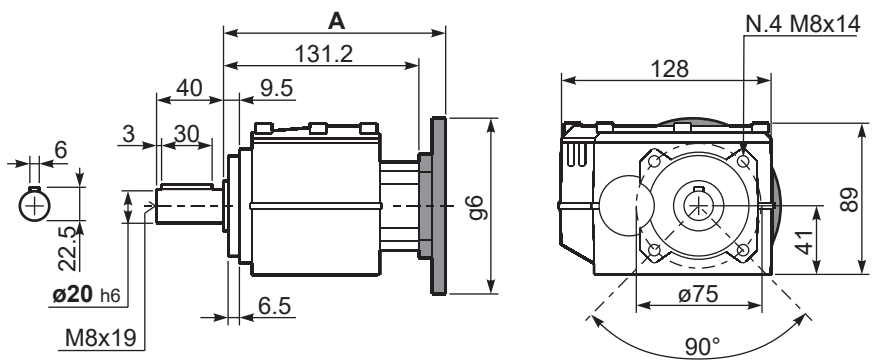

R302A-**N**...  
 Input Shaft  
 Albero in entrata

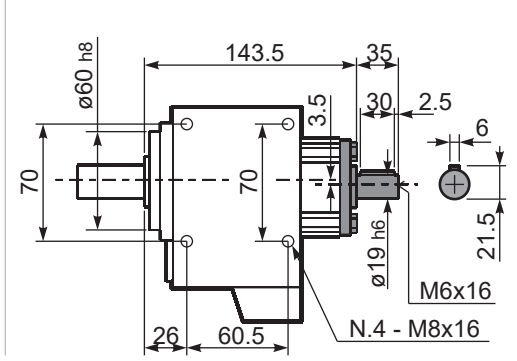

B5 Motor Flanges	A	C <sub>max</sub>	g6	k1	kit code
63 B5	151.7	170	140	155.2	K063.4.041
71 B5	149.7	180	160	153.2	K063.4.042
80/90 B5	151.7	200	200	155.2	K063.4.043

B14 Motor Flanges	A	C <sub>max</sub>	g6	k1	kit code
71 B14	149.7	152.5	105	153.2	K063.4.047
80 B14	151.7	160	120	155.2	K063.4.046
90 B14	151.7	170	140	155.2	K063.4.041