

QUICK SELECTION / Selezione veloce

input speed (n_1) = 1400 min⁻¹

Output Speed n_2 [min ⁻¹]	Ratio i	Motor power P_{1M} [kW]	Output torque M_{2M} [Nm]	Service factor $f.s.$	Nominal power P_{1R} [kW]	Nominal torque M_{2R} [Nm]	B5 motor flanges					B14 motor flanges			Output Shaft 	Ratios code
							-G	-H	-I	-L	CA	-	-	-		
							132	160	180	200	225	-	-	-		
294	4.75	45	1333	2.0	86.7	2700								3914		01
269	5.21	45	1460	1.9	82.1	2800								3913		02
220	6.36	45	1783	1.7	72.0	3000								3911		03
188	7.45	45	2088	1.6	67.7	3300								3014		04
172	8.15	45	2287	1.5	63.7	3400								3013		05
141	9.96	45	2792	1.3	55.2	3600								3011		06
120	11.69	45	3277	1.2	49.7	3800								2214		07
109	12.80	45	3589	1.1	47.7	4000								2213		08
90	15.63	45	4383	1.0	42.0	4300								2211	standard	09
79	17.65	37	4068	1.1	38.9	4500								1614	ø70	10
72	19.33	37	4455	1.0	35.6	4500								1613		11
67	20.77	30	3910	1.2	33.1	4500								1414		12
62	22.75	30	4282	1.1	30.2	4500								1413		13
59	23.60	30	4443	1.0	29.1	4500								1611		14
50	27.78	22	3842	1.2	24.7	4500								1411		15
45.5	30.76	22	4255	1.1	22.3	4500								1014		16
41.6	33.69	22	4660	1.0	20.4	4500								1013		17
34.0	41.15	18.5	4781	0.9	16.7	4500								1011		18

The dynamic efficiency is **0.96** for all ratios

Motor Flanges Available
Flange Motore Disponibili

B) Supplied with Reduction Bushing
Fornito con Bussola di Riduzione

B) Available on Request without reduction bushing
Disponibile a Richiesta senza Bussola di Riduzione

C) Motor Flange Holes Position
Posizione Fori Flangia Motore

EN Unit 1102 is supplied without lubricant and equipped with a breather, level and drain plugs. User can add mineral oil keeping existing plugs. Should the user wish to fill it with synthetic oil, it is recommended to replace the existing plugs with a closed plug.
See table 1 for lubrication and recommended quantity. In table 2 please see possible radial loads and axial loads on the gearbox.

I Il riduttore tipo 1102 è fornito privo di lubrificazione con tappi di sfiato, livello e scarico olio. L'utente può immettere olio minerale mantenendo i tappi esistenti. Se immetterà olio sintetico, dovrà sostituire i tappi esistenti con altri tipo chiuso.
Tab.1 per oli e quantità consigliati.
Tab.2 carichi radiali e assiali applicabili al riduttore.

D Das Getriebe der Baugröße 1102 wird ohne Schmiermittel geliefert. Es ist jedoch mit Einfüllschraube, Überdruckventil und Ablassschraube ausgerüstet. Das benötigte mineralische Öl kann über die Einfüllschraube eingefüllt werden. Sollte synthetisches Öl bevorzugt werden, so ist sind das eingebaute Überdruckventil durch eine geschlossenen Schraube zu ersetzen.
In Tabelle 1 ist die Schmiermenge und das empfohlene Schmiermittel angegeben
In Tabelle 2 sind die zulässigen Radial - und Axialbelastungen des Getriebes aufgeführt.

F Le réducteur de type 1102 est fourni sans lubrification et avec un bouchon de remplissage, de niveau et d'évacuation de l'huile. L'utilisateur peut y verser de l'huile minérale en conservant les bouchons existants. S'il y versera de l'huile synthétique, il devra substituer les bouchons existants avec d'autres bouchons de type fermé.
Voir tableau 1 concernant les huiles et les quantités conseillées.
Voir tableau 2 concernant les charges radiales et axiales applicables au réducteur

E El reductor tamaño 1102 se suministra sin lubricante, provisto de tapones de respiración, nivel y descarga de aceite. El usuario puede utilizar aceite mineral, manteniendo los tapones existentes. Si prefiere utilizar aceite sintético deberá sustituir los tapones existentes por tapones ciegos. La prerreducción se suministra con tapones ciegos, lubricado de por vida con aceite sintético. Ver tabla 1, para cantidades y aceites recomendados. En la tabla 2, se encuentran las cargas radiales y axiales admitidas por el reductor.

B3	B6	B7	B8	V5	V6	V8
6.50 LT	12.50 LT	7.50 LT	8.50 LT	14.50 LT	11.50 LT	Ask
SHELL Omala S2 GX 460				ENI Blasias 460		

For all details on lubrication and plugs check our website
Per maggiori dettagli su lubrificazione e tappi olio vedi il nostro sito web **tab. 1**

RADIAL AND AXIAL LOADS

Output shaft
Albero di uscita

$F_{eq} = F_R \cdot \frac{138}{X+68}$

n_2	FA	FR	n_2	FA	FR	n_2	FA	FR
300	2600	13000	140	3300	16500	70	4300	21500
250	2700	13500	120	3500	17500	40	5000	25000
200	3000	15000	85	3900	19500	15	5900	29500

Input shaft
Albero in entrata

n_1	FA	FR
1400	1120	5600
900	1220	6100
500	1300	6500

tab. 2

P1102**S0**... With foot
Con piedino

Gearbox weight
peso riduttore **165 kg**

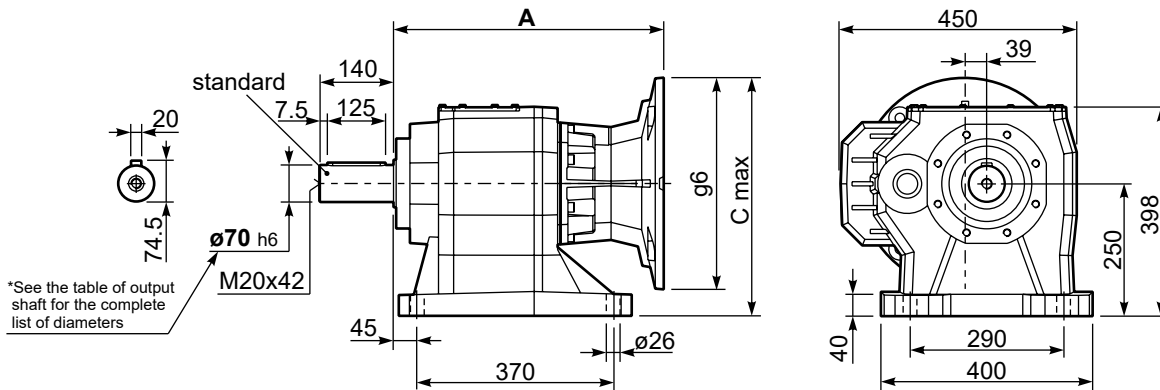

P1102-**F**... Output flanges
flange di uscita

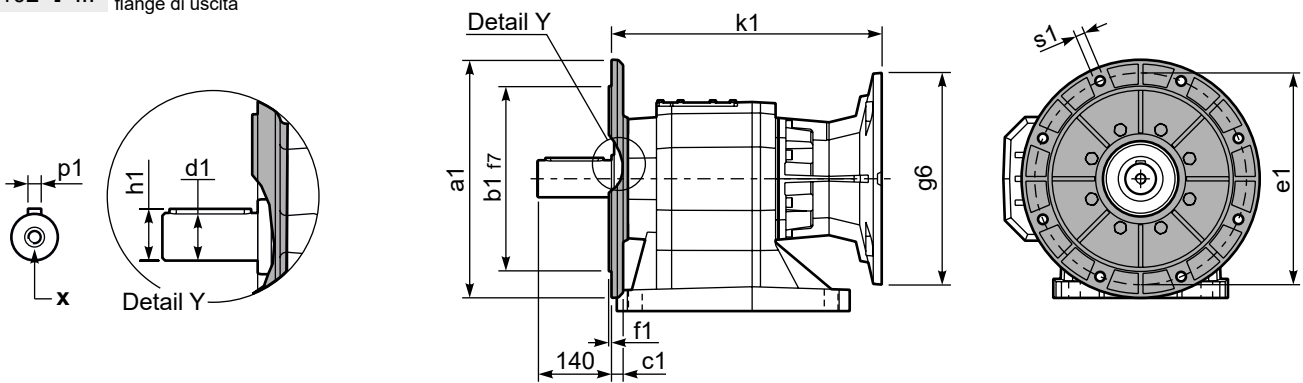

*Available output shaft / Albero di uscita

	Shaft - d1	p1	h1	x
Standard	ø 70x140	20	74.5	M20x42
On request A richiesta	-	-	-	-

Available output flanges / flange di uscita

a1 ø	b1	c1	e1	f1	s1	kit code
350	250	21	300	5	18	KC110.9.015
450	350	22	400	5	18	KC110.9.016
-	-	-	-	-	-	-

All flanges are compatible with the foot

P1102**S0**... Basic gearbox
Riduttore base

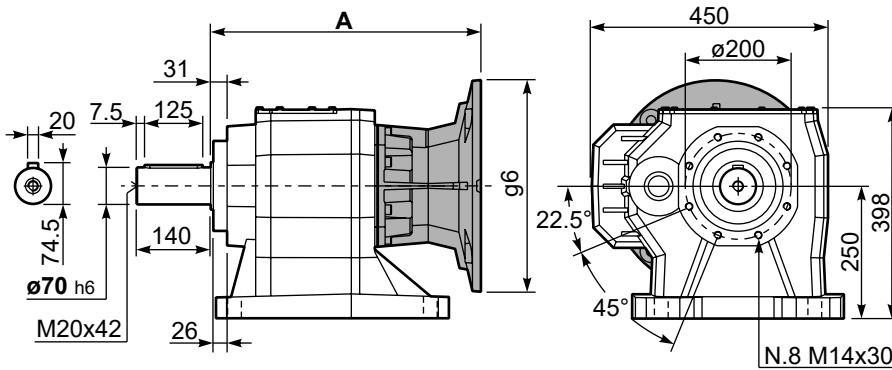

B5 Motor Flanges	A	C _{max}	g6	k1	kit code
132 B5	485.5	400	300	485.5	KC110.9.052
160 B5	510.5	425	350	510.5	KC110.9.053
180 B5	510.5	425	350	510.5	KC110.9.053 B
200 B5	510.5	450	400	510.5	KC110.9.054
225 B5	537.5	475	450	537.5	KC110.9.055

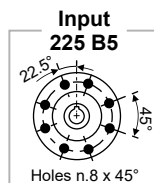

R1102**S0**... Input Shaft
Albero in entrata

