



QUICK SELECTION / Selezione veloce

input speed (n_1) = 1400 min⁻¹

Output Speed n_2 [min ⁻¹]	Ratio i	Motor power P_{1M} [kW]	Output torque M_{2M} [Nm]	Service factor f.s.	Nominal power P_{1R} [kW]	Nominal torque M_{2R} [Nm]	Available B5 motor flanges		Available B14 motor flanges			Output Shaft 	Ratios code
							-B	-C	-O	-P	-Q		
							63	71	56	63	71		
18.8	74.33	0.37	176	1.8	0.67	320			C	C		191313	01
17.0	82.56	0.37	196	1.6	0.60	320			C	C		151318	02
16.0	87.48	0.37	207	1.5	0.57	320			C	C		131713	03
13.8	101.40	0.37	240	1.3	0.49	320			C	C		151313	04
11.4	122.57	0.37	291	1.1	0.41	320			C	C		131313	05
10.1	138.59	0.37	329	1.0	0.36	320			C	C		101318	06
8.7	160.82	0.25	257	1.2	0.31	320			C	C		91713	07
8.2	170.20	0.25	272	1.2	0.29	320			C	C		101313	08
7.6	183.48	0.25	294	1.1	0.27	320			C	C		91318	09
6.5	214.15	0.18	262	1.2	0.23	320			C	C		71713	10
6.2	225.33	0.18	276	1.2	0.22	320			C	C		91313	11
5.7	244.32	0.18	299	1.1	0.20	320			C	C		71318	12
5.5	254.15	0.18	311	1.0	0.20	320			C	C		61713	13
4.8	289.96	0.18	355	0.9	0.17	320			C	C		61318	14
4.7	300.05	0.18	367	0.9	0.17	320			C	C		71313	15
3.9	356.09	0.12	282	1.1	0.14	320			C	C		61313	16

The dynamic efficiency is **0.94** for all ratios

Motor Flanges Available
Flange Motore Disponibili

B) Supplied with Reduction Bushing
Fornito con Bussola di Riduzione

B) Available on Request without reduction bushing
Disponibile a Richiesta senza Bussola di Riduzione

C) Motor Flange Holes Position
Posizione Fori Flangia Motore

EN Unit **FA43** is supplied with synthetic oil for lifetime lubrication, no maintenance is necessary. See table 1 for lubrication and recommended quantity. In table 2 please see possible radial loads and axial loads on the gearbox.

I Il riduttore **FA43** viene fornito completo di olio sintetico per la lubrificazione permanente e non necessita di alcuna manutenzione. Vedi tab.1 per oli e quantità consigliati. In tab.2 sono presenti i carichi radiali e assiali applicabili al riduttore.

D Das Getriebe **FA43** ist mit synthetischem Öl gefüllt und ist lebensdauergeschmiert. In Tabelle 1 ist die Schmiermenge und das empfohlene Schmiermittel angegeben. In Tabelle 2 sind die zulässigen Radial- und Axialbelastungen des Getriebes aufgeführt.

F Le réducteur **FA43** est fourni complet avec de l'huile synthétique pour la lubrification permanente et ne nécessite aucun entretien. Voir tableau 1 concernant les huiles et les quantités conseillées. Les charges radiales et axiales applicables au réducteur sont précisées dans le tableau 2.

E El reductor tamaño **FA43** se suministra, lubricado de por vida con aceite sintético y no requieren mantenimiento alguna. Ver tabla 1, para cantidades y aceites recomendados. En la tabla 2, se encuentran las cargas radiales y axiales admitidas por el reductor.

Standard supplied	For these mounting position specify in the order or add oil Per queste posizioni specificare in fase d'ordine o aggiungere olio				
H1	H4	H3	H2	H5	H6
1.30 LT	0.70 LT	0.70 LT	0.70 LT	1.35 LT	0.90 LT
SHELL Omala S4 WE 320			ENI Telium VSF 320		

For all details on lubrication and plugs check our website **tab. 1**
Per maggiori dettagli su lubrificazione e tappi olio vedi il nostro sito web

RADIAL AND AXIAL LOADS

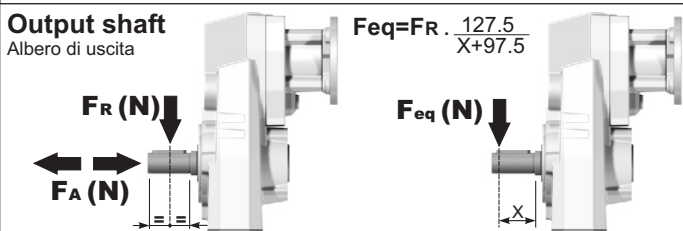

n_2 [min ⁻¹]	FA	FR	n_2 [min ⁻¹]	FA	FR	n_2 [min ⁻¹]	FA	FR
300	300	1500	140	390	1950	70	490	2450
250	320	1600	120	410	2050	40	590	2950
200	350	1750	85	460	2300	15	800	4000

On request reinforced bearings to increase loads.
A richiesta cuscinetti rinforzati per aumentare i carichi.

n_1	FA	FR
1400	140	700
900	160	800
500	190	950

tab. 2

PFA43C... Basic gearbox
Riduttore base

Gearbox weight **8.9 kg**
peso riduttore

M. flanges	Kit code	øF	A
63B5	K050.4.041	138	175
71B5	K050.4.042	160	172.5
56B14	KC40.4.049	80	172.5
63B14	K050.4.047	90	175
71B14	K050.4.045	105	172.5

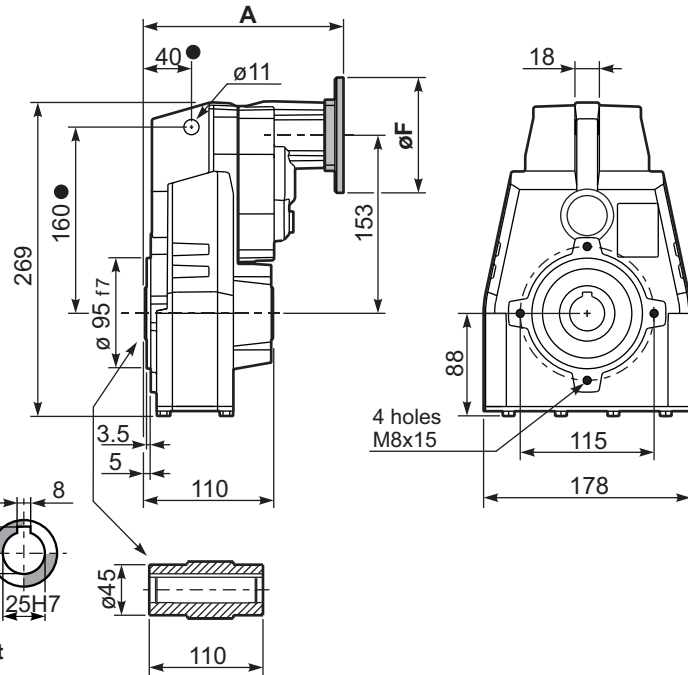

● Available torque arms,
see our web site
Bracci di reazione disponibili,
consulta il nostro sito web

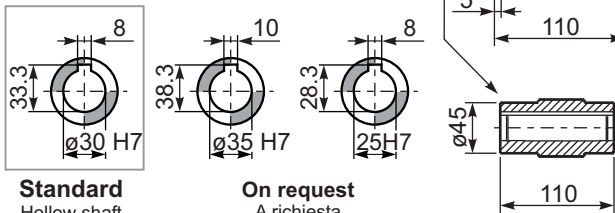

Standard
Hollow shaft

On request
A richiesta

PFA43...-F... Output flange
Flangia uscita

Motor Flange	k1
63B5	211
71B5	208.5
56B14	208.5
63B14	211
71B14	208.5

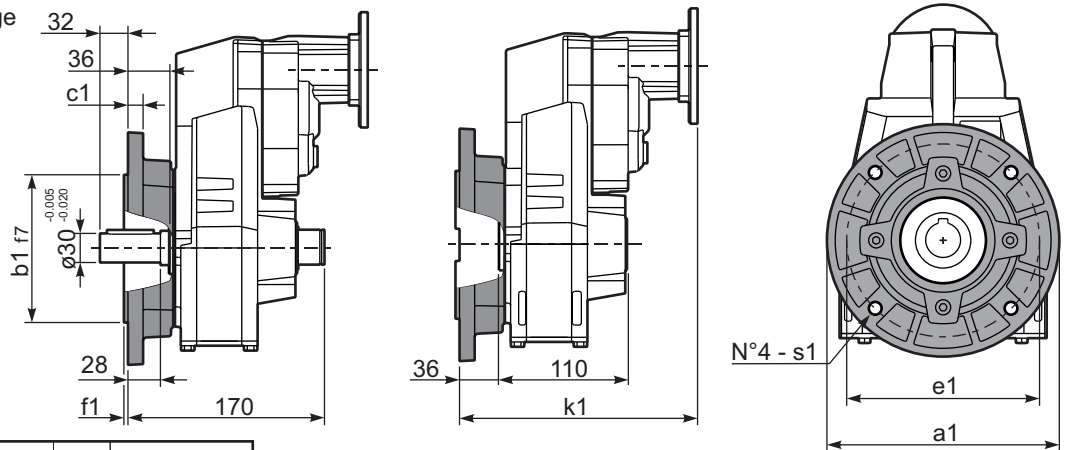

Available output flanges
Flange di uscita

a1 ø	b1	c1	e1	f1	s1	Kit code
160	110	10	130	3	9	KX5A.9.010
200	130	13	165	3.5	11	KX5A.9.011
250	180	14	215	4	14	KX5A.9.012

RFA43C... Input Shaft
Albero in entrata

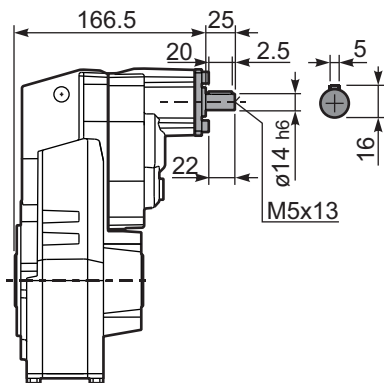

PFA43 A... Single output shaft
Albero uscita semplice

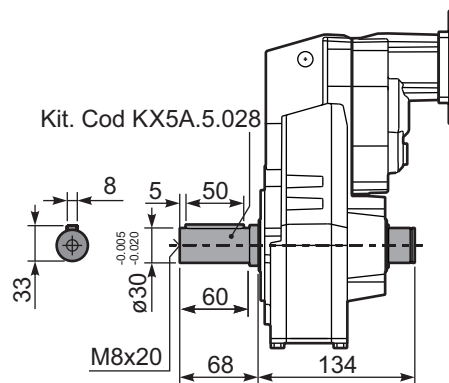

PFA43D... Shrink disk
Calettatore

