

QUICK SELECTION / Selezione veloce

input speed (n_1) = 1400 min⁻¹

Output Speed n_2 [min ⁻¹]	Ratio i	Motor power P_{1M} [kW]	Output torque M_{2M} [Nm]	Service factor f.s.	Nominal power P_{1R} [kW]	Nominal torque M_{2R} [Nm]	Available B5 motor flanges			Available B14 motor flanges		Dynamic efficiency RD	Tooth Module [mm]	 Ratios code
							-A	-B	-C	-P	-Q			
							56	63	71	63	71			
47	30.1	0.37	58	1.3	0.49	77				C		76	2.5	01
33	43.0	0.25	55	1.4	0.35	77				C		75	2.4	02
23	60.2	0.25	71	1.1	0.27	77				C		69	2.6	03
18.1	77.4	0.25	81	1.1	0.27	88				C		61	2.0	04
12.5	112	0.18	84	1.1	0.19	88				C		61	2.7	05
9.0	155	0.12	71	1.2	0.15	88				C		56	2.1	06
7.6	185	0.12	74	1.0	0.12	77				C		49	1.8	07
5.4	258	0.12*	77	<0.8	0.09	77				C		47	1.3	08
4.8	292	0.12*	66	<0.8	0.08	66				C		44	1.2	09
4.1	344	0.12*	44	<0.8	0.05	44				C		40	1.0	10
3.3	430	0.12*	44	<0.8	0.04	44				C		36	0.8	11

A Motor Flanges Available
Flange Motore Disponibili

B Supplied with Reduction Bushing
Fornito con Bussola di Riduzione

B Available on Request without reduction bushing
Disponibile a Richiesta senza Bussola di Riduzione

C Motor Flange Holes Position
Posizione Fori Flangia Motore

* Power higher than the maximum one which can be supported by the gearbox. Select according to the torque M_{2R}
Potenza superiore a quella massima sopportabile dal riduttore. Selezionare in base al momento torcente M_{2R}

EN Unit P50 is supplied with synthetic oil, providing "long life" lubrication. For mounting position V5-V6 please contact us. See table 1 for lubrication and recommended quantity. In table 2 please see possible radial loads and axial loads on the gearbox.

I Il riduttore tipo P50 viene fornito lubrificato a vita con olio sintetico. Per posizioni V5-V6 contattare il ns. servizio tecnico. Vedi tab.1 per oli e quantità consigliati. In tab.2 sono presenti i carichi radiali e assiali applicabili al riduttore.

D Für die Lebensdauerschmierung ist das Getriebe der Größe P50 mit synthetischem Öl befüllt. Bei Einbaulage V5 oder V6 bitten wir um Rücksprache. In Tabelle 1 ist die Schmiermenge und das empfohlene Schmiermittel angegeben. In Tabelle 2 sind die zulässigen Radial - und Axialbelastungen des Getriebes aufgeführt.

F Le réducteur de type P50 est fourni lubrifié à vie avec de l'huile synthétique. Concernant les positions V5.V6, contactez notre service d'assistance technique. Voir tableau 1 concernant les huiles et les quantités conseillées. Les charges radiales et axiales applicables au réducteur sont précisées dans le tableau 2.

E El reductor tamaño P50 se suministra, lubricado de por vida con aceite sintético. Para las posiciones V5 y V6 contactar con nuestro servicio técnico. Ver tabla 1, para cantidades y aceites recomendados. En la tabla 2, se encuentran las cargas radiales y axiales admitidas por el reductor.

LUBRICATION P50 Oil Common lubrication 0.26 l (A + B).

SHELL Omala S4 WE 320	ENI Telium VSF 320
------------------------------	---------------------------

For all details on lubrication and plugs check our website **tab. 1**
Per maggiori dettagli su lubrificazione e tappi olio vedi il nostro sito web

RADIAL AND AXIAL LOADS

Output shaft
Albero di uscita

n_2 [min ⁻¹]	FA [N]	FR [N]
75	340	1700
50	380	1900
25	480	2500
15-6	560	2800

Input shaft
albero in entrata

n_1 [min ⁻¹]	FA [N]	FR [N]
1400	44	220

*Strong axial loads in the DX direction are not allowed.
Non sono consentiti forti carichi assiali con direzione DX

tab. 2

Rightangle - Gear 88Nm **P50**

PP50FB... Basic wormbox Riduttore base

Gearbox weight
peso riduttore **3.80 kg**

M. flanges	Kit code	øF	A
56B5	K050.4.046	120	142
63B5	K050.4.041	138	144
71B5	K050.4.042	160	141.5
63B14	K050.4.047	90	144
71B14	K050.4.045	105	141.5

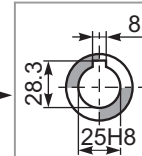
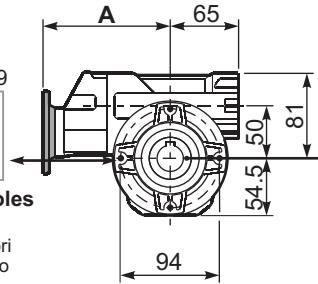
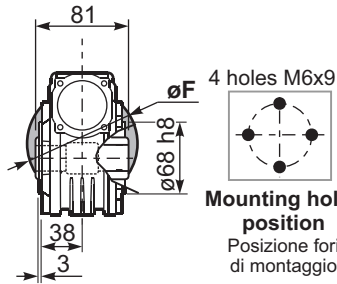

Standard
Hollow shaft

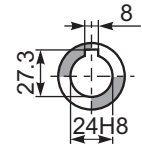

On Request "type S"
A richiesta "tipo S"

PP50PA... Feet Piedini

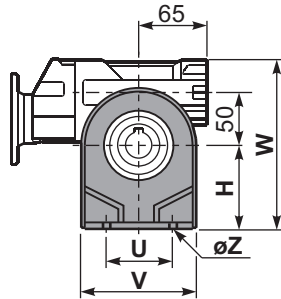
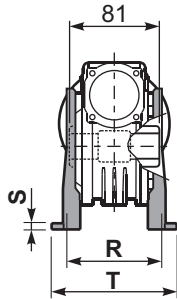

PP50PB... Feet Piedini

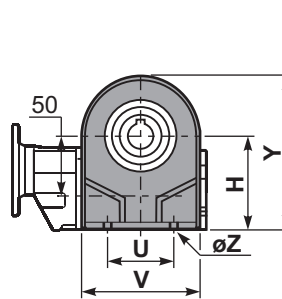

PP50PV... Feet Piedini

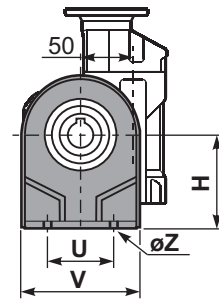

	H	R	S	T	U	V	Y	W	øZ	kit code
type B	82	98.5	3.5	123	63	113	138.5	163	ø10.5	K050.9.022
type S	85	96	10	114	85	110	139.5	166	ø10	KS050.9.023

PP50FC... Output flange Flangia uscita

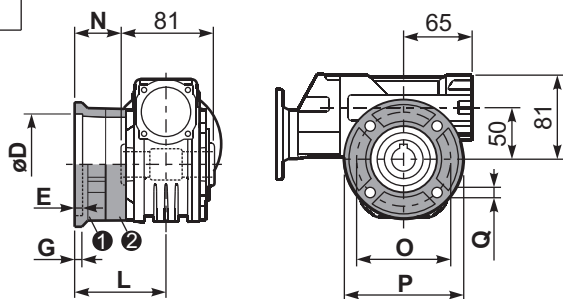

type B	øD	E	G	L	N	O	P	Q	kit code
FC	70 ^{+0.20} / _{+0.15}	9	12	85	44.5	90	123	10.5	① K050.9.010 ② -
FL	70 ^{+0.20} / _{+0.15}	9	12	114.5	74	90	123	10.5	① K050.9.010 ② K050.0.200

type S	øD	E	G	L	N	O	P	Q	kit code
F1	110 ^{+0.20} / _{+0.15}	4	11	83.5	43	130	160	10	① KS050.9.012 ② -
F2	70 ^{+0.20} / _{+0.15}	9	12	76.5	36	90	123	10.5	① KS050.9.014 ② -
F3	95 ^{+0.035} / ₀	4	10	66.5	26	115	140	10	① KS050.9.013 ② -

PP50BR... Reaction arm Braccio di reazione

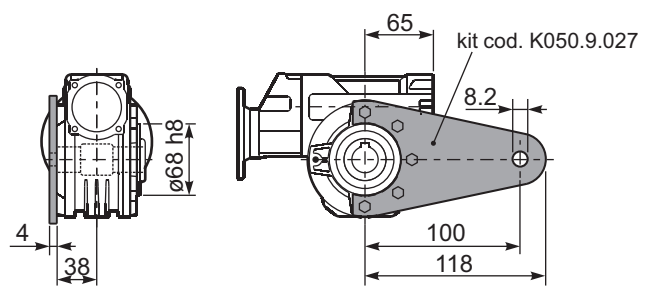

PP50....S... Single Shaft Albero lento semplice

PP50....D... Double Shaft Albero lento bisp.

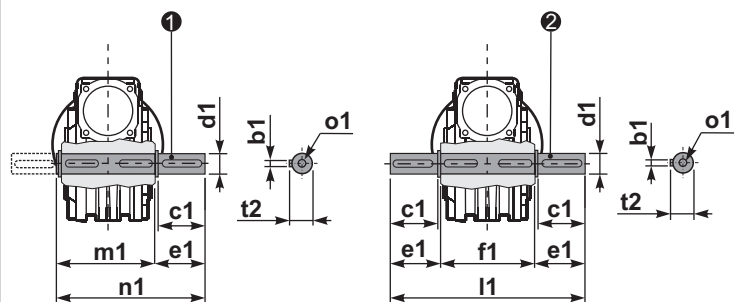

① kit cod. K050.5.028 type B
kit cod. KS050.5.030 type S

② kit cod. K050.5.029 type B

RP50FB... Input shaft Albero in entrata

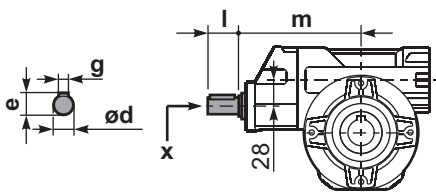

	ød	e	g	l	m	x
type B	14 h6	16	5	25	135.5	M5x13
type S	-	-	-	-	-	-

	b1	c1	d1	e1	f1	l1	m1	n1	t2	o1
type B	8	52	25 ^{-0.005} / _{-0.020}	59.5	81	200	86.5	146	28	M8x20
type S	8	50	24 ^{-0.005} / _{-0.020}	68.8	-	-	86.5	155	27	M8x20