

QUICK SELECTION / Selezione veloce

input speed (n_1) = 1400 min⁻¹

Output Speed n_2 [min ⁻¹]	Ratio i	Motor power P_{1M} [kW]	Output torque M_{2M} [Nm]	Service factor f.s.	Nominal power P_{1R} [kW]	Nominal torque M_{2R} [Nm]	Available B5 motor flanges		Available B14 motor flanges			Dynamic efficiency RD	Tooth Module [mm]	Ratios code
							-B	-C	-O	-P	-Q			
							63	71	56	63	71			
5.6	252	0.25	198	1.5	0.38	304	B		B-C	B-C		46	2.7	01
3.9	360	0.25	258	1.2	0.29	304	B		B-C	B-C		42	2.7	02
2.8	504	0.18	241	1.3	0.23	304	B		B-C	B-C		39	2.7	03
1.9	756	0.12	204	1.5	0.18	304	B		B-C	B-C		33	2.7	04
1.4	1008	0.12	256	1.2	0.14	304	B		B-C	B-C		31	2.7	05
1.1	1332	0.12	327	0.9	0.11	304	B		B-C	B-C		30	2.7	06
0.8	1656	0.12*	304	<0.8	0.10	304	B		B-C	B-C		28	2.7	07
0.6	2160	0.12*	304	<0.8	0.08	304	B		B-C	B-C		26	2.7	08
0.6	2520	0.12*	304	<0.8	0.07	304	B		B-C	B-C		25	2.7	09

A) Motor Flanges Available
Flange Motore Disponibili

B) Supplied with Reduction Bushing
Fornito con Bussola di Riduzione

B) Available on Request without reduction bushing
Disponibile a Richiesta senza Bussola di Riduzione

C) Motor Flange Holes Position
Posizione Fori Flangia Motore

* Power higher than the maximum one which can be supported by the gearbox. Select according to the torque M_{2R}
Potenza superiore a quella massima sopportabile dal riduttore. Selezionare in base al momento torcente M_{2R}

EN Unit **6A4** is supplied with synthetic oil, providing "long life" lubrication. For mounting position V5-V6 please contact us. See table 1 for lubrication and recommended quantity. In table 2 please see possible radial loads and axial loads on the gearbox.

I Il riduttore tipo **6A4** viene fornito lubrificato a vita con olio sintetico. Per posizioni V5-V6 contattare il ns. servizio tecnico. Vedi tab.1 per oli e quantità consigliati. In tab.2 sono presenti i carichi radiali e assiali applicabili al riduttore.

D Für die Lebensdauerschmierung ist das Getriebe der Größe **6A4** mit synthetischem Öl befüllt. Bei Einbaulage V5 oder V6 bitten wir um Rücksprache. In Tabelle 1 ist die Schmiermenge und das empfohlene Schmiermittel angegeben. In Tabelle 2 sind die zulässigen Radial- und Axialbelastungen des Getriebes aufgeführt.

F Le réducteur de type **6A4** est fourni lubrifié à vie avec de l'huile synthétique. Concernant les positions V5.V6, contactez notre service d'assistance technique. Voir tableau 1 concernant les huiles et les quantités conseillées. Les charges radiales et axiales applicables au réducteur sont précisées dans le tableau 2.

E El reductor tamaño **6A4** se suministra, lubricado de por vida con aceite sintético. Para las posiciones V5 y V6 contactar con nuestro servicio técnico. Ver tabla 1, para cantidades y aceites recomendados. En la tabla 2, se encuentran las cargas radiales y axiales admitidas por el reductor.

■ LUBRICATION 6A4 Oil 0.40 Lt. 0.09 Lt.

SHELL Omala S4 WE 320 **ENI** Telium VSF 320

For all details on lubrication and plugs check our website **tab. 1**
Per maggiori dettagli su lubrificazione e tappi olio vedi il nostro sito web

■ RADIAL AND AXIAL LOADS

Output shaft
Albero di uscita

n_2 [min ⁻¹]	FA [N]	FR [N]
25	700	3800
15	800	4000

Input shaft
albero in entrata

n_1 [min ⁻¹]	FA [N]	FR [N]
1400	42	210

***Strong axial loads in the DX direction are not allowed.**
Non sono consentiti forti carichi assiali con direzione DX

tab. 2

P6A4FB... Basic wormbox
Riduttore base

M. flanges	Kit code	øF	A
63B5	K050.4.041	138	74
71B5	K050.4.042	160	71.5
56B14	KC40.4.049	80	71.5
63B14	K050.4.047	90	74
71B14	K050.4.045	105	71.5

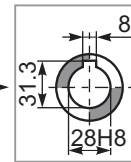
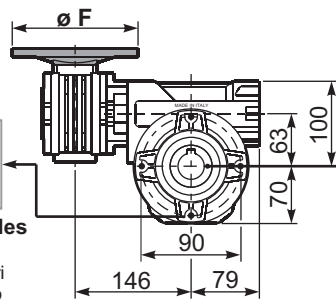
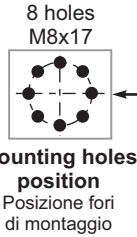
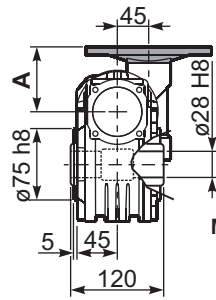

Standard
Hollow shaft

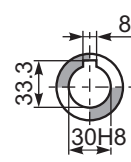

On request
A richiesta

Gearbox weight
peso riduttore **8.90 kg**

P6A4PA... Feet
Piedini

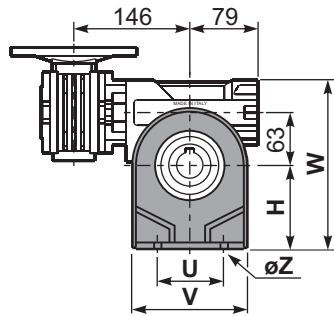
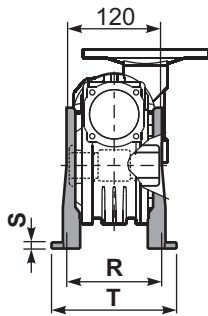

P6A4PB... Feet
Piedini

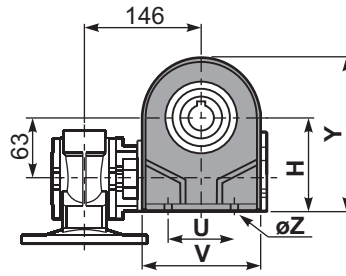

P6A4PV... Feet
Piedini

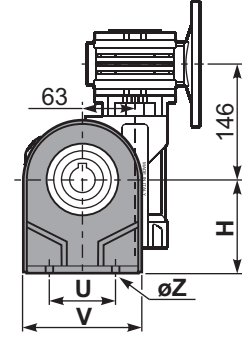

	H	R	S	T	U	V	Y	W	øZ	kit code
type B	115	115	12	142	120	156	185	215	ø11	K070.9.022
type S	-	-	-	-	-	-	-	-	-	-

P6A4FC... Output flange
Flangia uscita

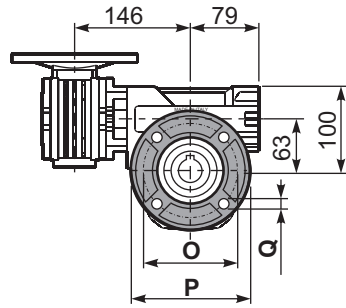
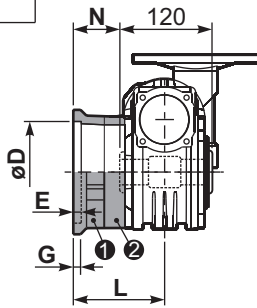

type B	øD	E	G	L	N	O	P	Q	kit code
FC	130 ^{+0.20} / _{+0.15}	7	13	85	25	165	200	13	① K070.9.010 ② -
FL	130 ^{+0.20} / _{+0.15}	7	13	111	51	165	200	13	① K070.9.010 ② K070.0.200
type S	øD	E	G	L	N	O	P	Q	kit code
F1	130 ^{+0.20} / _{+0.15}	7	13	111	51	165	200	13	① KS070.9.014 ② -
F2	115 ^{+0.20} / _{+0.15}	7	13	116	56	150	175	11	① KS063.9.013 ② -
F3	110 ^{+0.035} / ₀	5	13.5	84.5	24.5	130	160	11	① KS070.9.011 ② -

P6A4BR... Reaction arm
Braccio di reazione

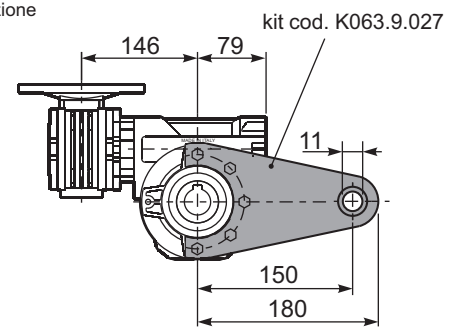
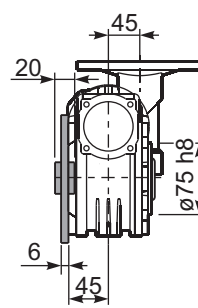

P6A4....S... Single Shaft
Albero lento semplice

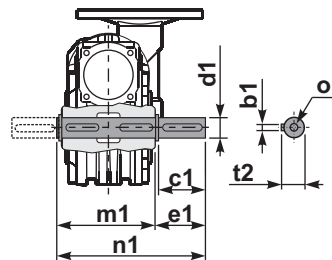

P6A4....D... Double Shaft
Albero lento bisp.

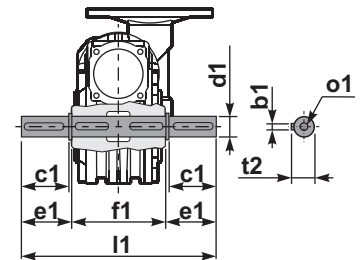

① kit cod. K070.5.028 type B

② kit cod. K070.5.029 type B

R6A4FB... Input shaft
Albero in entrata

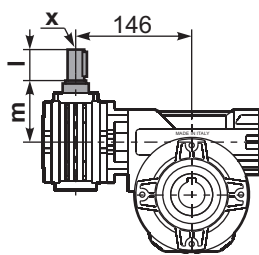
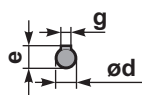

	ød	e	g	l	m	x	kit code
type B	11 h6	12.5	4	30	68	-	① K045.5.006 PAM71 ② -
type S	-	-	-	-	-	-	① - ② -

	b1	c1	d1	e1	f1	l1	m1	n1	t2	o1
type B	8	60	28 ^{-0.005} / _{-0.020}	63.5	120	247	127.5	191	31	M8x20
type S	-	-	-	-	-	-	-	-	-	-