

Aluminum one step gearboxes

A modular and compact product

4

Alloy housing

Is vacuum impregnated (MIL-STD 276) for protection and sealing. No secondary finish required but readily accepts paint

Flange

Fully modular to IEC and Compact integrated motor. NEMA C flange

Gears

Hardened and ground gears.

Removable inspection cover

Allows periodic inspection of gearing during routine maintenance

Output shaft

With well proportioned bearings

Feet

Removable feet.

Single-piece aluminum alloy housing

Combines light weight with high tensile strength. Precision machined for alignment of bearings and gearing

Ideal for use as first step with wormgearboxes.

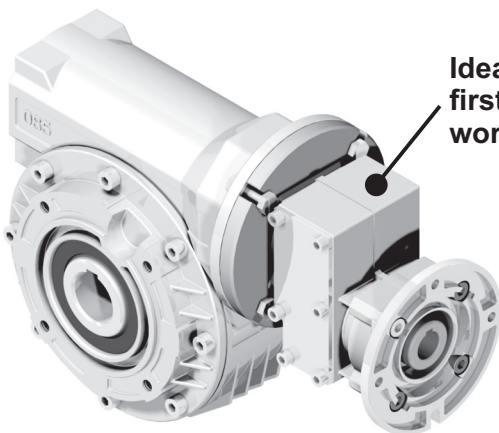

World wide sales network.

Lubricated for life with synthetic oil with operative range from -15° to +130°C

