



QUICK SELECTION / Selezione veloce input speed (n₁) = 1400 min⁻¹

Output Speed n ₂ [min ⁻¹]	Ratio i	Motor power P _{1M} [kW]	Output torque M _{2M} [Nm]	Service factor f.s.	Nominal power P _{1R} [kW]	Nominal torque M _{2R} [Nm]	Available B5 motor flanges				Available B14 motor flanges			Output Shaft	Ratios code
							-B	-C	-D	-E	-Q	-R	-T		
							63	71	80	90	71	80	90		
35.2	39.79	1.5	382	0.9	1.4	360	B				C	C		191316	01
29.6	47.22	1.1	331	1.1	1.2	360	B				C	C		191314	02
25.6	54.73	1.1	384	0.9	1.0	360	B				C	C		171314	03
21.1	66.22	0.75	318	1.0	0.78	330	B				C	C		171312	04
18.3	76.69	0.75	369	1.0	0.73	360	B				C	C		131314	05
16.7	83.59	0.55	297	1.2	0.67	360	B				C	C		190814	06
15.1	92.78	0.55	329	1.0	0.55	330	B				C	C		131312	07
13.4	104.68	0.55	371	1.0	0.54	360	B				C	C		101314	08
11.9	117.22	0.37	278	1.2	0.44	330	B				C	C		170812	09
11.1	126.65	0.37	300	1.1	0.41	330	B				C	C		101312	10
10.2	136.62	0.37	324	1.1	0.41	360	B				C	C		91314	11
8.5	165.29	0.25	264	1.2	0.31	330	B				C	C		91312	12
7.8	180.40	0.25	289	1.2	0.31	360	B				C	C		71314	13
6.4	218.26	0.25	349	0.9	0.24	330	B				C	C		71312	14
5.8	241.82	0.25	387	0.9	0.23	360	B				C	C		90814	15
4.8	292.57	0.18	358	0.9	0.18	330	B				C	C		90812	16
4.4	319.32	0.18	391	0.9	0.18	360	B				C	C		70814	17
3.6	386.33	0.12	305	1.1	0.13	330	B				C	C		70812	18
2.9	480.16	0.12	380	0.7	0.08	255	B				C	C		70810	19

The dynamic efficiency is **0.94** for all ratios

 Motor Flanges Available Flange Motore Disponibili
 B) Supplied with Reduction Bushing Fornito con Bussola di Riduzione
 B) Available on Request without reduction bushing Disponibile a Richiesta senza Bussola di Riduzione
 C) Motor Flange Holes Position Posizione Fori Flangia Motore

EN Unit **513A** is supplied with synthetic oil for lifetime lubrication, no maintenance is necessary. See table 1 for lubrication and recommended quantity. In table 2 please see possible radial loads and axial loads on the gearbox.

I Il riduttore **513A** viene fornito completo di olio sintetico per la lubrificazione permanente e non necessita di alcuna manutenzione. Vedi tab.1 per oli e quantità consigliati. In tab.2 sono presenti i carichi radiali e assiali applicabili al riduttore.

D Das Getriebe **513A** ist mit synthetischem Öl gefüllt und ist lebensdauergeschmiert. In Tabelle 1 ist die Schmiermenge und das empfohlene Schmiermittel angegeben. In Tabelle 2 sind die zulässigen Radial - und Axialbelastungen des Getriebes aufgeführt.

F Le réducteur **513A** est fourni complet avec de l'huile synthétique pour la lubrification permanente et ne nécessite aucun entretien. Voir tableau 1 concernant les huiles et les quantités conseillées. Les charges radiales et axiales applicables au réducteur sont précisées dans le tableau 2.

E El reductor tamaño **513A** se suministra, lubricado de por vida con aceite sintético y no requieren mantenimiento alguna. Ver tabla 1, para cantidades y aceites recomendados. En la tabla 2, se encuentran las cargas radiales y axiales admitidas por el reductor.

Standard supplied	For these mounting position specify in the order or add oil Per queste posizioni specificare in fase d'ordine o aggiungere olio						
1.00 LT	0.90 LT	1.25 LT	1.15 LT	1.45 LT	1.40 LT	Ask	Ask
SHELL Omala S4 WE 320				ENI Telium VSF 320			

For all details on lubrication and plugs check our website **tab. 1**
Per maggiori dettagli su lubrificazione e tappi olio vedi il nostro sito web

RADIAL AND AXIAL LOADS

Output shaft
Albero di uscita

$F_{eq} = F_R \cdot \frac{54}{X+24}$

$F_{eq} (N)$

n ₂	FA	FR	n ₂	FA	FR	n ₂	FA	FR
300	460	2300	140	600	3000	70	780	3900
250	480	2400	120	620	3100	40	900	4500
200	520	2600	85	700	3500	15	1000	5000

Input shaft
Albero in entrata

n ₁	FA	FR
1400	400	2000
900	440	2200
500	440	2200

tab. 2

P513A **B1** ... With feet
Con piedini

Gearbox weight **11.9 kg**
peso riduttore With feet **12.1 Kg**

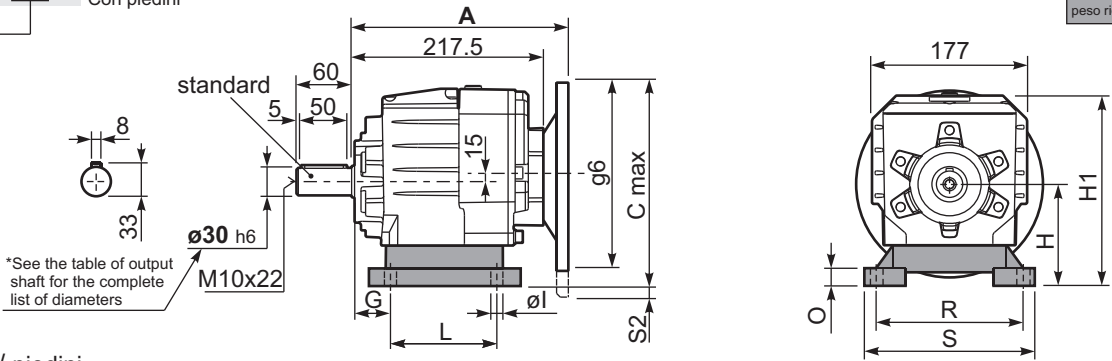

Feet / piedini

Feet Code	Market reference	G	H	R	L	S	H1	O	øl	S2 only with motor flange	B5 max. Flange	kit code
B3	312/3	18	110	160	130	190	211	20	11	-	-	KC50.9.024
B4	30/35	20	130	180	149.5	216	231	18	14	-	-	KC60.9.024
S4	47-57	30	115	135	165	170	216	25	14	-	-	KC50.9.022
H3	023-233	30	130	135	135	185	231	25	14	-	-	KC50.9.025
M2	52/3	30	110	135-150	100	190	211	18	11	-	-	KC50.9.023

Other feet are available, see our web site
Sono disponibili altri piedini, consulta il nostro sito web

A see on page bottom

Most popular types
Tipi più diffusi

P513A-**F** ... Output flanges
flange di uscita

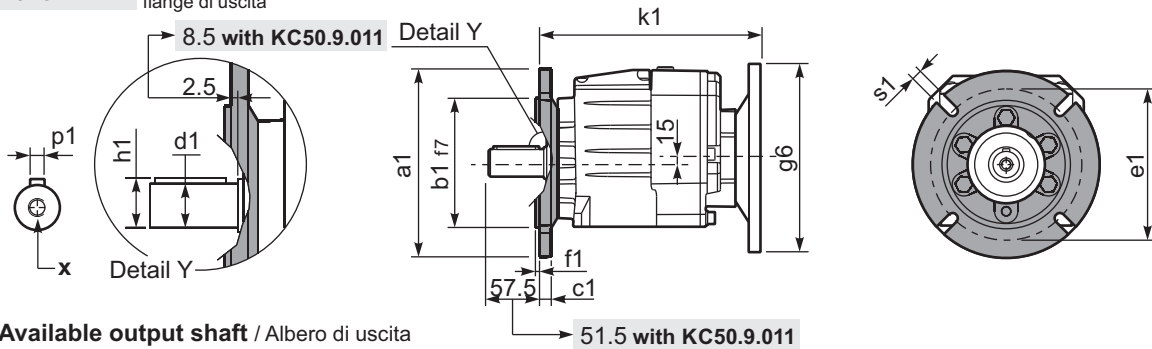

*Available output shaft / Alberi di uscita

	Shaft - d1	p1	h1	x
Standard	ø 30x60	8	33	M10x22
On request A richiesta	ø 24x50	8	27	M8x19
	ø 25x50	8	28	M8x19
	ø 28x60	8	31	M8x19
	ø 35x60	10	38	M10x22

Available output flanges / flange di uscita

a1 ø	b1	c1	e1	f1	s1	kit code
160	110	14	130	3.5	11	KC50.9.011
200	130	13	165	3.5	11	KC50.9.012
250	180	15.5	215	4	14	KC50.9.013

With flange and feet only on request. Ask for compatibility

P513A-**N** ... Basic gearbox
Riduttore base

R513A-N ... Input Shaft
Albero in entrata

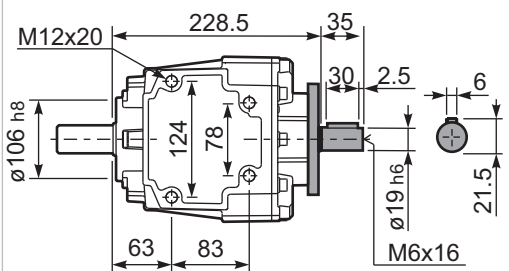
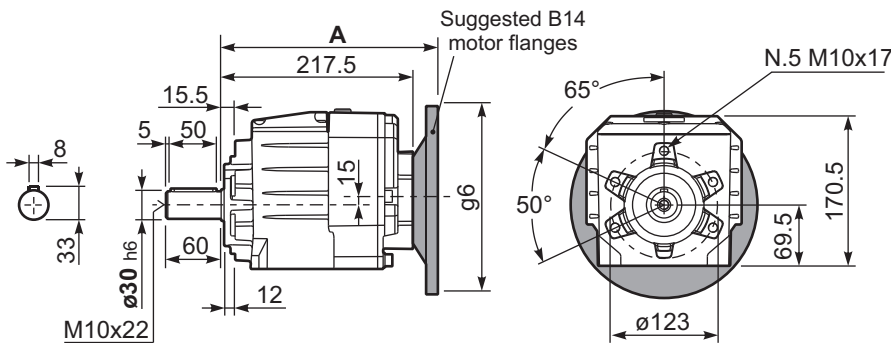

B5 Motor Flanges	A	C _{max}	g6	k1	kit code	k1 with KC50.9.011
63 B5	238	215	140	240.5	K063.4.041	246.5
71 B5	236	225	160	238.5	K063.4.042	244.5
80/90 B5	238	245	200	240.5	K063.4.043	246.5

B14 Motor Flanges	A	C _{max}	g6	k1	kit code	k1 with KC50.9.011
71 B14	236	197.5	105	238.5	K063.4.047	244.5
80 B14	238	205	120	240.5	K063.4.046	246.5
90 B14	238	215	140	240.5	K063.4.041	246.5