



QUICK SELECTION / Selezione veloce

input speed (n_1) = 1400 min⁻¹

Output Speed n_2 [min ⁻¹]	Ratio i	Motor power P_{1M} [kW]	Output torque M_{2M} [Nm]	Service factor f.s.	Nominal power P_{1R} [kW]	Nominal torque M_{2R} [Nm]	Available B5 motor flanges				Available B14 motor flanges			Output Shaft \varnothing	Ratios code
							-B	-C	-D	-E	-Q	-R	-T		
							63	71	80	90	71	80	90		
22.3	62.76	1.5	603	1.1	1.68	675	B				C	C		191213	01
20.2	69.28	1.5	665	1.0	1.52	675	B				C	C		191212	02
19.2	72.75	1.5	698	1.0	1.45	675	B				C	C		171213	03
17.4	80.29	1.5	771	0.9	1.31	675	B				C	C		171212	04
16.4	85.39	1.1	599	1.1	1.23	675	B				C	C		151213	05
14.9	94.25	1.1	661	1.0	1.12	675	B				C	C		151212	06
13.7	101.92	1.1	715	0.9	1.03	675	B				C	C		131213	07
12.4	112.50	0.75	541	1.2	0.94	675	B				C	C		131212	08
11.9	117.29	0.75	564	1.2	0.90	675	B				C	C		151210	09
10.1	139.13	0.75	669	1.0	0.76	675	B				C	C		101213	10
9.1	153.56	0.75	739	0.9	0.69	675	B				C	C		101212	11
7.7	181.57	0.55	644	1.0	0.58	675	B				C	C		91213	12
7.0	200.42	0.55	711	0.9	0.53	675	B				C	C		91212	13
5.6	249.41	0.37	592	1.1	0.42	675	B				C	C		91210	14
4.3	329.33	0.37	781	0.9	0.32	675	B				C	C		71210	15

The dynamic efficiency is **0.94** for all ratios

A Motor Flanges Available
Flange Motore Disponibili

B Supplied with Reduction Bushing
Fornito con Bussola di Riduzione

B Available on Request without reduction bushing
Disponibile a Richiesta senza Bussola di Riduzione

C Motor Flange Holes Position
Posizione Fori Flangia Motore

E Unit **713C** is supplied with synthetic oil for lifetime lubrication, no maintenance is necessary. See table 1 for lubrication and recommended quantity. In table 2 please see possible radial loads and axial loads on the gearbox.

I Il riduttore **713C** viene fornito completo di olio sintetico per la lubrificazione permanente e non necessita di alcuna manutenzione. Vedi tab.1 per oli e quantità consigliati. In tab.2 sono presenti i carichi radiali e assiali applicabili al riduttore.

D Das Getriebe **713C** ist mit synthetischem Öl gefüllt und ist lebensdauergeschmiert. In Tabelle 1 ist die Schmiermenge und das empfohlene Schmiermittel angegeben. In Tabelle 2 sind die zulässigen Radial- und Axialbelastungen des Getriebes aufgeführt.

F Le réducteur **713C** est fourni complet avec de l'huile synthétique pour la lubrification permanente et ne nécessite aucun entretien. Voir tableau 1 concernant les huiles et les quantités conseillées. Les charges radiales et axiales applicables au réducteur sont précisées dans le tableau 2.

E El reductor tamaño **713C** se suministra, lubricado de por vida con aceite sintético y no requieren mantenimiento alguna. Ver tabla 1, para cantidades y aceites recomendados. En la tabla 2, se encuentran las cargas radiales y axiales admitidas por el reductor.

B3	B6	B7	B8	V5	V6	V8
1.60 LT	2.20 LT	1.80 LT	1.70 LT	2.80 LT	1.90 LT	Ask

SHELL Omala S4 WE 320

ENI Telium VSF 320

For all details on lubrication and plugs check our website

Per maggiori dettagli su lubrificazione e tappi olio vedi il nostro sito web

tab. 1

RADIAL AND AXIAL LOADS

Output shaft
Albero di uscita

$$F_{eq} = F_R \cdot \frac{78}{X+38}$$

n_2	FA	FR	n_2	FA	FR	n_2	FA	FR
300	680	3400	140	960	4800	70	1300	6500
250	760	3800	120	1040	5200	40	1460	7300
200	900	4500	85	1120	5600	15	1800	9000

Input shaft
Albero in entrata

n_1	FA	FR
1400	400	2000
900	440	2200
500	440	2200

tab. 2

P713C**S6**... With feet
Con piedini

Gearbox weight **34.5 kg**
peso riduttore With feet **36.2 kg**

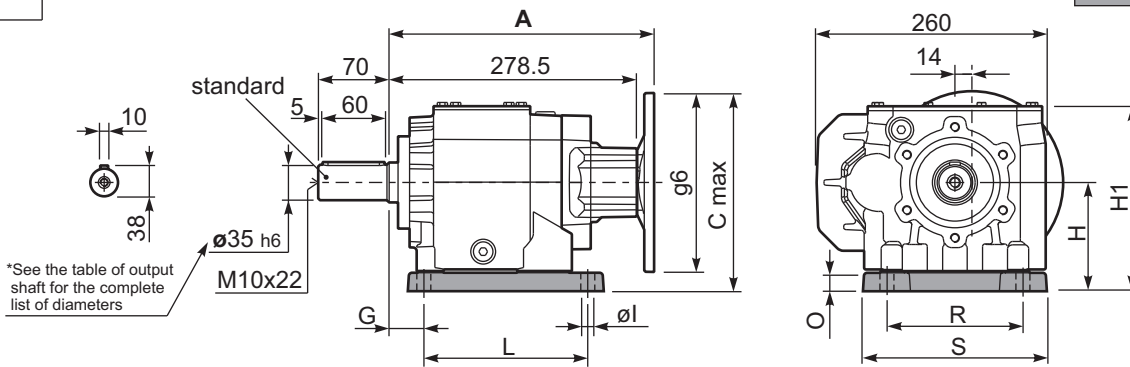

Feet / piedini

Feet Code	Market reference	G	H	R	L	S	H1	O	øl	B5 max. Flange	kit code
B4	412/3	19.5	130	180	149.5	220	220	25	14	-	KC71.9.022
S6	67	30	130	150	195	210	220	25	14	-	KC71.9.024

P713C-**F**... Output flanges
flange di uscita

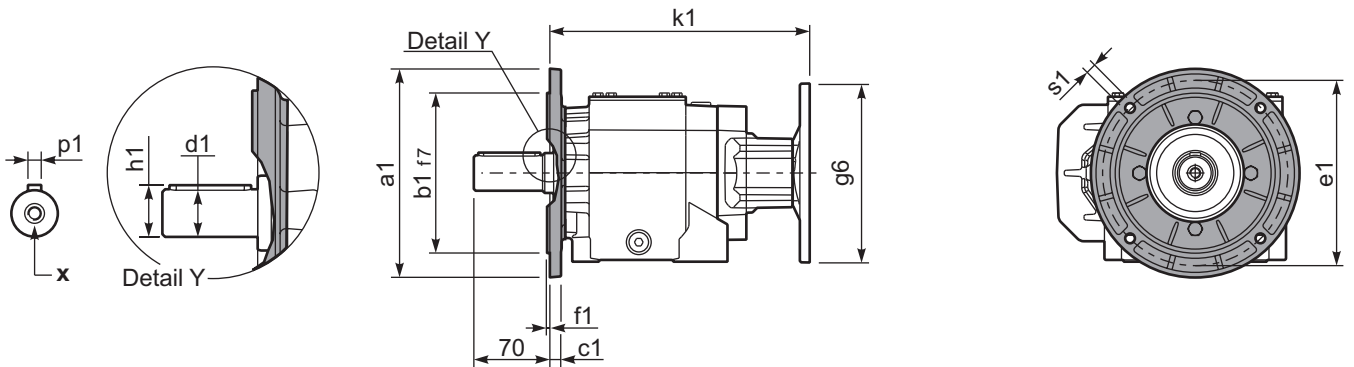

***Available output shaft / Albero di uscita**

	Shaft - d1	p1	h1	x
Standard	ø 35x70	10	38	M10x22
On request A richiesta	ø 38x70	10	41	M10x25

Available output flanges / flange di uscita

a1 ø	b1	c1	e1	f1	s1	kit code
200	130	11	165	3.5	11	KC71.9.012
250	180	13	215	4	14	KC81.9.013
-	-	-	-	-	-	-

With flange and feet only on request. Ask for compatibility

P713C-**N**... Basic gearbox
Riduttore base

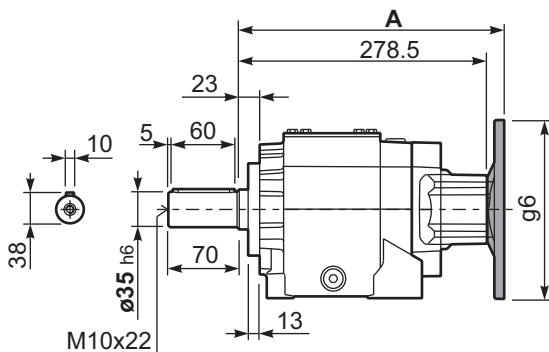

B5 Motor Flanges	A	C _{max}	g6	k1	kit code
63 B5	299	200	140	299	K063.4.041
71 B5	297	210	160	297	K063.4.042
80/90 B5	299	230	200	299	K063.4.043

R713C-N... Input Shaft
Albero in entrata

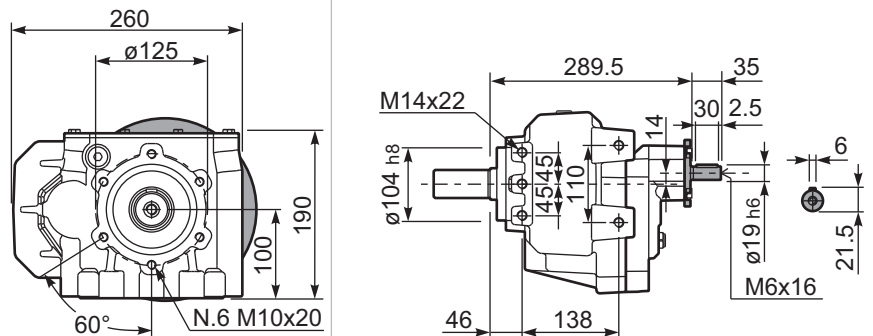

B14 Motor Flanges	A	C _{max}	g6	k1	kit code
71 B14	297	182.5	105	297	K063.4.047
80 B14	299	190	120	299	K063.4.046
90 B14	299	200	140	299	K063.4.041