

#### QUICK SELECTION / Selezione veloce

input speed ( $n_1$ ) = 1400 min<sup>-1</sup>

Output Speed $n_2$ [min <sup>-1</sup> ]	Ratio $i$	Motor power $P_{1M}$ [kW]	Output torque $M_{2M}$ [Nm]	Service factor f.s.	Nominal power $P_{1R}$ [kW]	Nominal torque $M_{2R}$ [Nm]	B5 motor flanges				B14 motor flanges		Output Shaft 	Ratios code 
							-F	-G	-H	-I	-U	-V		
							100 112	132	160	180	100 112	132		
317	4.42	22	611	1.1	24.2	700						3015	01	
264	5.30	22	733	1.0	20.2	700						3013	02	
219	6.38	18.5	742	1.1	19.1	800						3011	03	
168	8.33	15	784	1.0	14.7	800						2015	04	
140	9.99	15	940	1.0	13.8	900						2013	05	
124	11.26	15	1060	1.0	14.9	1100						1615	06	
116	12.03	15	1132	1.1	15.2	1200						2011	07	
104	13.50	15	1271	1.1	15.8	1400						1613	08	
96	14.65	15	1378	1.1	15.6	1500						1315	09	
86	16.26	15	1531	1.0	14.1	1500						1611	10	
80	17.56	11	1214	1.2	13.0	1500						1313	11	
65	21.50	11	1486	1.1	11.4	1600						1113	12	
54	25.88	9	1526	1.0	9.4	1600						1111	13	
45.0	31.09	7.5	1475	1.0	7.2	1460						813	14	
37.4	37.43	5.5	1312	1.2	6.5	1600						811	15	

The dynamic efficiency is **0.96** for all ratios

- Motor Flanges Available  
Flange Motore Disponibili
- Supplied with Reduction Bushing  
Fornito con Bussola di Riduzione
- Available on Request without reduction bushing  
Disponibile a Richiesta senza Bussola di Riduzione
- Motor Flange Holes Position  
Posizione Fori Flangia Motore

**EN** Unit **862C** is supplied without lubricant and equipped with a breather, level and drain plugs. User can add mineral oil keeping existing plugs. Should the user wish to fill it with synthetic oil, it is recommended to replace the existing plugs with a closed plug.  
See table 1 for lubrication and recommended quantity.  
In table 2 please see possible radial loads and axial loads on the gearbox.

**I** Il riduttore tipo **862C** è fornito privo di lubrificazione con tappi di sfiato, livello e scarico olio. L'utente può immettere olio minerale mantenendo i tappi esistenti. Se immetterà olio sintetico, dovrà sostituire i tappi esistenti con altri tipo chiuso.  
Tab.1 per oli e quantità consigliati.  
Tab.2 carichi radiali e assiali applicabili al riduttore.

**D** Das Getriebe der Baugröße **862C** wird ohne Schmiermittel geliefert. Es ist jedoch mit Einfüllschraube, Überdruckventil und Ablassschraube ausgerüstet. Das benötigte mineralische Öl kann über die Einfüllschraube eingefüllt werden. Sollte synthetisches Öl bevorzugt werden, so ist sind das eingebaute Überdruckventil durch eine geschlossenen Schraube zu ersetzen.  
In Tabelle 1 ist die Schmiermenge und das empfohlene Schmiermittel angegeben  
In Tabelle 2 sind die zulässigen Radial - und Axialbelastungen des Getriebes aufgeführt.

**F** Le réducteur de type **862C** est fourni sans lubrification et avec un bouchon de remplissage, de niveau et d'évacuation de l'huile. L'utilisateur peut y verser de l'huile minérale en conservant les bouchons existants. S'il y versera de l'huile synthétique, il devra substituer les bouchons existants avec d'autres bouchons de type fermé.  
Voir tableau 1 concernant les huiles et les quantités conseillées.  
Voir tableau 2 concernant les charges radiales et axiales applicables au réducteur

**E** El reductor tamaño **862C** se suministra sin lubricante, provisto de tapones de respiración, nivel y descarga de aceite. El usuario puede utilizar aceite mineral, manteniendo los tapones existentes. Si prefiere utilizar aceite sintético deberá sustituir los tapones existentes por tapones ciegos. La prerreducción se suministra con tapones ciegos, lubricado de por vida con aceite sintético.  
Ver tabla 1, para cantidades y aceites recomendados.  
En la tabla 2, se encuentran las cargas radiales y axiales admitidas por el reductor.

B3	B6	B7	B8	V5	V6	V8
3.10 LT	4.50 LT	2.50 LT	3.10 LT	4.90 LT	4.20 LT	Ask
SHELL Omala S2 GX 460				ENI Blasias 460		

For all details on lubrication and plugs check our website  
Per maggiori dettagli su lubrificazione e tappi olio vedi il nostro sito web **tab. 1**

### RADIAL AND AXIAL LOADS

**Output shaft**  
Albero di uscita

$F_{eq} = F_R \cdot \frac{88.5}{X+38.5}$

$n_2$	FA	FR	$n_2$	FA	FR	$n_2$	FA	FR
300	1800	9000	140	2400	12000	70	3000	15000
250	2000	10000	120	2600	13000	40	3200	16000
200	2200	11000	85	2800	14000	15	4000	20000

**On request reinforced bearings to increase loads.**  
A richiesta cuscinetti rinforzati per aumentare i carichi.

**Input shaft**  
Albero in entrata

$n_1$	FA	FR
1400	700	3500
900	840	4200
500	900	4500

**tab. 2**

# Coaxial - Gear 1600Nm 862C

P862C**S8**... With foot  
Con piedino

Gearbox weight With flange **84.0 kg**  
peso riduttore With feet **74.5 kg**

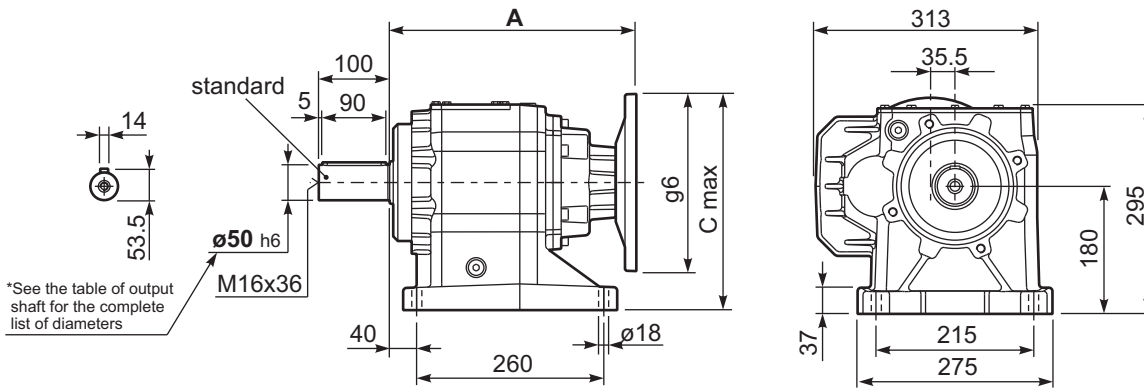

P862C-**F**... Output flanges  
flange di uscita

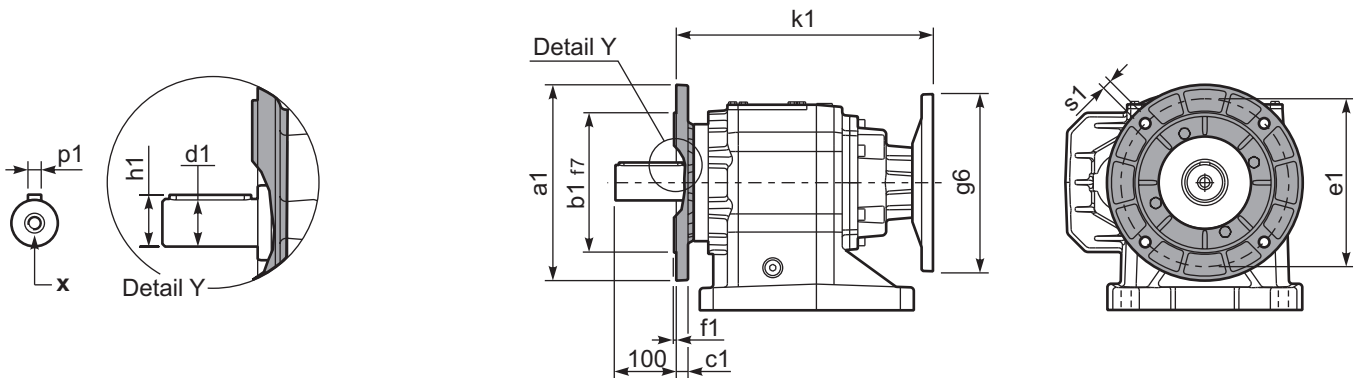

\*Available output shaft / Albero di uscita

	Shaft - d1	p1	h1	x
Standard	∅ 50x100	14	53.5	M16x36
On request A richiesta	∅ 60x120	18	64	M20x42
	-	-	-	-

Available output flanges / flange di uscita

a1 ∅	b1	c1	e1	f1	s1	kit code
300	230	21	265	4	14	KC90.9.014
350	250	21	300	5	18	KC90.9.015
-	-	-	-	-	-	-

All flanges are compatible with the foot

P862C**S8**... Basic gearbox  
Riduttore base

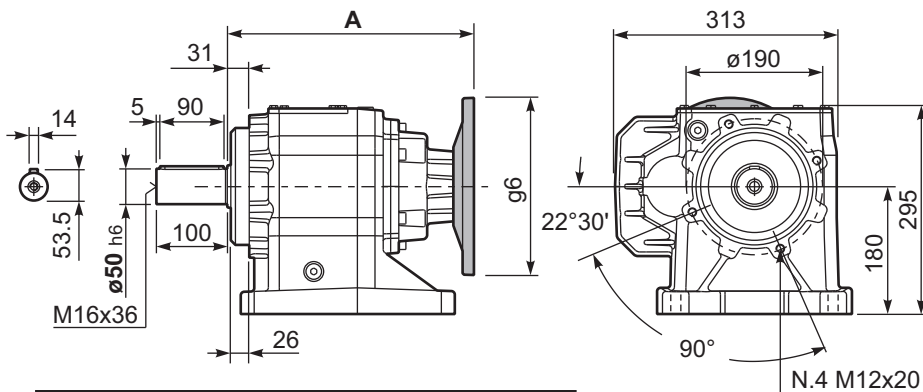

B5 Motor Flanges	A	C <sub>max</sub>	g6	k1	kit code
100/112 B5	348.5	305	250	348.5	K023.4.043
132 B5	370	330	300	370	KC51.4.043C
160/180 B5	402	355	350	402	KC86.4.0.43

B14 Motor Flanges	A	C <sub>max</sub>	g6	k1	kit code
100/112 B14	348.5	260	160	348.5	K085.4.047
132 B14	370	280	200	370	KC51.4.041C
-	-	-	-	-	-

R862C**S8**... Input Shaft  
Albero in entrata

