

QUICK SELECTION / Selezione veloce

input speed (n_1) = 1400 min⁻¹

Output Speed n_2 [min ⁻¹]	Ratio i	Motor power P_{1M} [kW]	Output torque M_{2M} [Nm]	Service factor f.s.	Nominal power P_{1R} [kW]	Nominal torque M_{2R} [Nm]	Available B5 motor flanges					Available B14 motor flanges				Output Shaft \varnothing	Ratios code	
							-C	-D	-E	-F	-G	-R	-T	-U	-V			
							71	80	90	100 112	132	80	90	100 112	132			
32.5	43.03	5.5	1478	1.1	5.8	1600	B									201313	standard $\varnothing 50$ $\varnothing 60$ On request	01
28.9	48.52	5.5	1667	0.9	5.0	1550	B									161315		02
27.0	51.81	4	1302	1.2	4.8	1600	B									201311		03
24.1	58.17	4	1462	1.1	4.3	1600	B									161313		04
22.2	63.09	4	1585	1.0	3.8	1550	B									131315		05
20.0	70.05	4	1760	1.0	4.0	1800	B									161311		06
18.5	75.65	4	1901	0.9	3.7	1800	B									131313		07
15.4	91.09	3	1723	1.0	3.1	1800	B									131311		08
12.6	111.50	2.2	1553	1.2	2.5	1800	B									111311		09
10.5	133.91	2.2	1865	1.0	2.1	1800	B									81313		10
8.7	161.24	1.5	1548	1.2	1.7	1800	B									81311		11
7.6	184.40	1.1	1293	1.1	1.2	1450	B									61313		12
6.3	222.04	1.1	1557	1.1	1.2	1750	B									61311		13

The dynamic efficiency is **0.94** for all ratios

A Motor Flanges Available
Flange Motore Disponibili

B Supplied with Reduction Bushing
Fornito con Bussola di Riduzione

B Available on Request without reduction bushing
Disponibile a Richiesta senza Bussola di Riduzione

C Motor Flange Holes Position
Posizione Fori Flangia Motore

EN Unit **863C** is supplied without lubricant and equipped with a breather, level and drain plugs. User can add mineral oil keeping existing plugs. Should the user wish to fill it with synthetic oil, it is recommended to replace the existing plugs with a closed plug.
See table 1 for lubrication and recommended quantity.
In table 2 please see possible radial loads and axial loads on the gearbox.

I Il riduttore tipo **863C** è fornito privo di lubrificazione con tappi di sfiato, livello e scarico olio. L'utente può immettere olio minerale mantenendo i tappi esistenti. Se immetterà olio sintetico, dovrà sostituire i tappi esistenti con altri tipo chiuso.
Tab.1 per oli e quantità consigliati.
Tab.2 carichi radiali e assiali applicabili al riduttore.

D Das Getriebe der Baugröße **863C** wird ohne Schmiermittel geliefert. Es ist jedoch mit Einfüllschraube, Überdruckventil und Ablassschraube ausgerüstet. Das benötigte mineralische Öl kann über die Einfüllschraube eingefüllt werden. Sollte synthetisches Öl bevorzugt werden, so ist sind das eingebaute Überdruckventil durch eine geschlossenen Schraube zu ersetzen.
In Tabelle 1 ist die Schmiermenge und das empfohlene Schmiermittel angegeben
In Tabelle 2 sind die zulässigen Radial - und Axialbelastungen des Getriebes aufgeführt.

F Le réducteur de type **863C** est fourni sans lubrification et avec un bouchon de remplissage, de niveau et d'évacuation de l'huile. L'utilisateur peut y verser de l'huile minérale en conservant les bouchons existants. S'il y versera de l'huile synthétique, il devra substituer les bouchons existants avec d'autres bouchons de type fermé.
Voir tableau 1 concernant les huiles et les quantités conseillées.
Voir tableau 2 concernant les charges radiales et axiales applicables au réducteur

E El reductor tamaño **863C** se suministra sin lubricante, provisto de tapones de respiración, nivel y descarga de aceite. El usuario puede utilizar aceite mineral, manteniendo los tapones existentes. Si prefiere utilizar aceite sintético deberá sustituir los tapones existentes por tapones ciegos. La prerreducción se suministra con tapones ciegos, lubricado de por vida con aceite sintético.
Ver tabla 1, para cantidades y aceites recomendados.
En la tabla 2, se encuentran las cargas radiales y axiales admitidas por el reductor.

B3	B6	B7	B8	V5	V6	V8
3.10 LT	4.60 LT	2.60 LT	3.10 LT	5.60 LT	4.30 LT	Ask
SHELL Omala S2 GX 460				ENI Blasias 460		

For all details on lubrication and plugs check our website [www.863c.com](#) **tab. 1**
Per maggiori dettagli su lubrificazione e tappi olio vedi il nostro sito web

RADIAL AND AXIAL LOADS

Output shaft
Albero di uscita

$F_{eq} = F_R \cdot \frac{88.5}{X+38.5}$

n_2	FA	FR	n_2	FA	FR	n_2	FA	FR
300	1800	9000	140	2400	12000	70	3000	15000
250	2000	10000	120	2600	13000	40	3200	16000
200	2200	11000	85	2800	14000	15	4000	20000

On request reinforced bearings to increase loads.
A richiesta cuscinetti rinforzati per aumentare i carichi.

Input shaft
Albero in entrata

n_1	FA	FR
1400	450	2250
900	500	2500
500	600	3000

tab. 2

Coaxial - Gear 1800Nm 863C

P863C**S8**... With foot
Con piedino

Gearbox weight
peso riduttore With flange **78.5 kg**
With feet **69.0 kg**

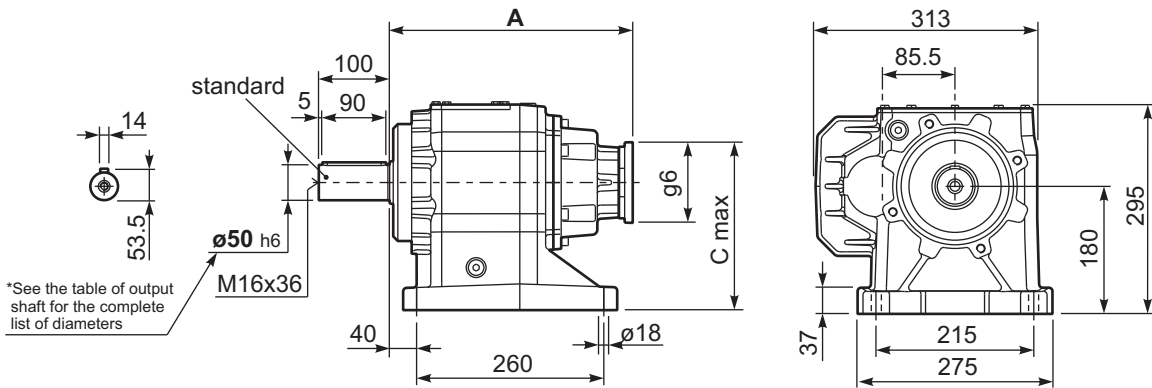

P863C-**F**... Output flanges
flange di uscita

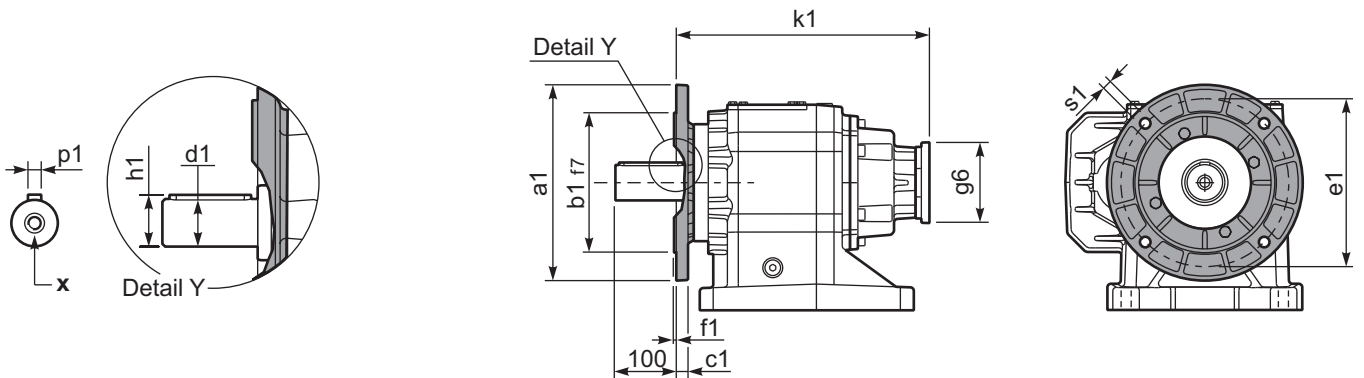

*Available output shaft / Albero di uscita

	Shaft - d1	p1	h1	x
Standard	∅ 50x100	14	53.5	M16x36
On request A richiesta	∅ 60x120	18	64	M20x42

Available output flanges / flange di uscita

a1 ∅	b1	c1	e1	f1	s1	kit code
300	230	21	265	4	14	KC90.9.014
350	250	21	300	5	18	KC90.9.015
-	-	-	-	-	-	-

All flanges are compatible with the foot

P863C**S8**... Basic gearbox
Riduttore base

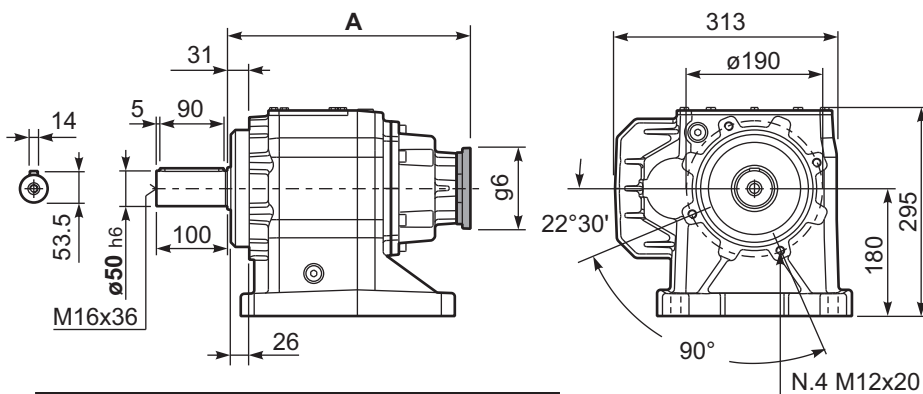

B5 Motor Flanges	A	C _{max}	g6	k1	kit code
71 B5	342	260	160	342	K023.4.041
80/90 B5	344	280	200	344	K023.4.042
100/112 B5	353	305	250	353	K023.4.043
132 B5	374	330	300	374	KC51.4.043

B14 Motor Flanges	A	C _{max}	g6	k1	kit code
80 B14	344	240	120	344	K085.4.046
90 B14	344	250	140	344	K085.4.045
100/112 B14	353	260	160	353	K085.4.047
132 B14	374	280	200	374	KC51.4.041

R863C**S8**... Input Shaft
Albero in entrata

