



#### QUICK SELECTION / Selezione veloce

input speed ( $n_1$ ) = 1400 min<sup>-1</sup>

Output Speed $n_2$ [min <sup>-1</sup> ]	Ratio $i$	Motor power $P_{1M}$ [kW]	Output torque $M_{2M}$ [Nm]	Service factor f.s.	Nominal power $P_{1R}$ [kW]	Nominal torque $M_{2R}$ [Nm]	Available B5 motor flanges		Available B14 motor flanges			Dynamic efficiency <b>RD</b>	Tooth Module  [mm]	 Ratios code
							-B	-C	-O	-P	-Q			
							63	71	56	63	71			
200	<b>7</b>	0.37	14	2.9	<b>1.07</b>	<b>41</b>	<b>B</b>		B-C	B-C		80	2.2	01
140	<b>10</b>	0.37	20	2.2	<b>0.82</b>	<b>44</b>	<b>B</b>		B-C	B-C		79	2.2	02
100	<b>14</b>	0.37	27	1.6	<b>0.60</b>	<b>44</b>	<b>B</b>		B-C	B-C		77	2.4	03
67	<b>21</b>	0.37	36	1.2	<b>0.44</b>	<b>42</b>	<b>B</b>		B-C	B-C		67	1.6	04
50	<b>28</b>	0.37	46	1.0	<b>0.38</b>	<b>47</b>	<b>B</b>		B-C	B-C		65	2.5	05
38	<b>37</b>	0.25	40	1.0	<b>0.26</b>	<b>41</b>	<b>B</b>		B-C	B-C		63	1.8	06
30	<b>46</b>	0.25	46	0.9	<b>0.22</b>	<b>41</b>	<b>B</b>		B-C	B-C		59	1.5	07
23	<b>60</b>	0.18	41	1.0	<b>0.18</b>	<b>41</b>	<b>B</b>		B-C	B-C		56	1.2	08
20	<b>70</b>	0.12	31	1.0	<b>0.12</b>	<b>30</b>	<b>B</b>		B-C	B-C		54	1.0	09
13.7	<b>102</b>	0.09	31	0.9	<b>0.09</b>	<b>29</b>	<b>B</b>		B-C	B-C		49	0.72	10

**A** Motor Flanges Available  
Flange Motore Disponibili

**B** Supplied with Reduction Bushing  
Fornito con Bussola di Riduzione

**B** Available on Request without reduction bushing  
Disponibile a Richiesta senza Bussola di Riduzione

**C** Motor Flange Holes Position  
Posizione Fori Flangia Motore

\* Power higher than the maximum one which can be supported by the gearbox. Select according to the torque  $M_{2R}$   
Potenza superiore a quella massima sopportabile dal riduttore. Selezionare in base al momento torcente  $M_{2R}$

**EN** Unit M45 is supplied with synthetic oil, providing "long life" lubrication. For mounting position V5-V6 please contact us. See table 1 for lubrication and recommended quantity. In table 2 please see possible radial loads and axial loads on the gearbox.

**I** Il riduttore tipo M45 viene fornito lubrificato a vita con olio sintetico. Per posizioni V5-V6 contattare il ns. servizio tecnico. Vedi tab.1 per oli e quantità consigliati. In tab.2 sono presenti i carichi radiali e assiali applicabili al riduttore.

**D** Für die Lebensdauerschmierung ist das Getriebe der Größe M45 mit synthetischem Öl befüllt. Bei Einbaulage V5 oder V6 bitten wir um Rücksprache. In Tabelle 1 ist die Schmiermenge und das empfohlene Schmiermittel angegeben. In Tabelle 2 sind die zulässigen Radial- und Axialbelastungen des Getriebes aufgeführt.

**F** Le réducteur de type M45 est fourni lubrifié à vie avec de l'huile synthétique. Concernant les positions V5.V6, contactez notre service d'assistance technique. Voir tableau 1 concernant les huiles et les quantités conseillées. Les charges radiales et axiales applicables au réducteur sont précisées dans le tableau 2.

**E** El reductor tamaño M45 se suministra, lubricado de por vida con aceite sintético. Para las posiciones V5 y V6 contactar con nuestro servicio técnico. Ver tabla 1, para cantidades y aceites recomendados. En la tabla 2, se encuentran las cargas radiales y axiales admitidas por el reductor.

#### LUBRICATION M45 Oil Quantity 0.09 Lt.

SHELL Omala S4 WE 320

ENI Telium VSF 320

For all details on lubrication and plugs check our website **tab. 1**  
Per maggiori dettagli su lubrificazione e tappi olio vedi il nostro sito web

#### RADIAL AND AXIAL LOADS

**Output shaft**  
Albero di uscita

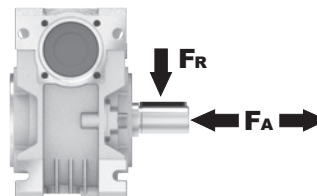

$n_2$ [min <sup>-1</sup> ]	FA [N]	FR [N]
200	180	900
150	200	1000
100	220	1100
75	240	1200
50	260	1400
25	300	1800
15	400	2000

**Input shaft**  
albero in entrata

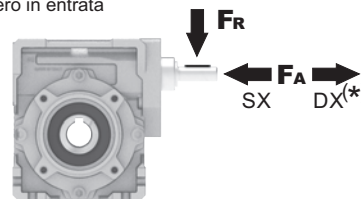

$n_1$ [min <sup>-1</sup> ]	FA [N]	FR [N]
1400	42	210

\*Strong axial loads in the DX direction are not allowed.  
Non sono consentiti forti carichi assiali con direzione DX

**tab. 2**

**PM45FB...** Basic wormbox  
Riduttore base

M. flanges	Kit code	øF	A
63B5	K050.4.041	138	80
71B5	K050.4.042	160	77.5
56B14	KC40.4.049	80	77.5
63B14	K050.4.047	90	80
71B14	K050.4.045	105	77.5

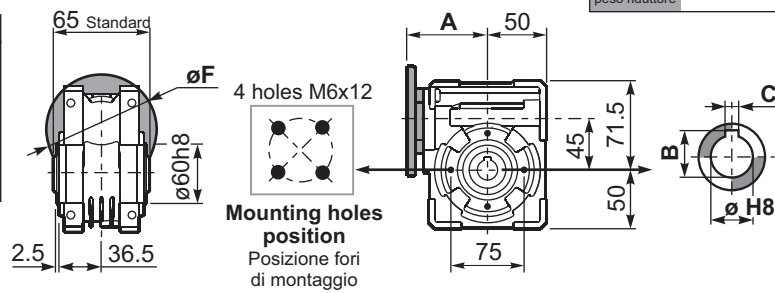

ø H8	B	C	*Spacer code
18 Standard	20.8	6	KM45.3.018
19 on request	21.8	6	KM45.3.019
20 on request	22.8	6	KM45.3.020

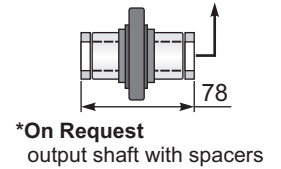

**PM45FC...** Square flange  
Flangia quadrata

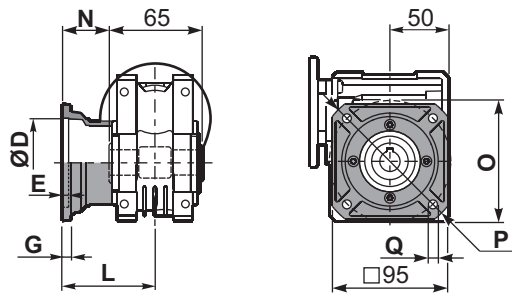

type B	øD	E	G	L	N	O	P	Q	kit code
FC	60 H8	4	7	67	34.5	75	110	9	KM45.9.010
FL	60 H8	4	7	97	64.5	75	110	9	KM45.9.011

**PM45F1...** Round flange  
Flangia rotonda

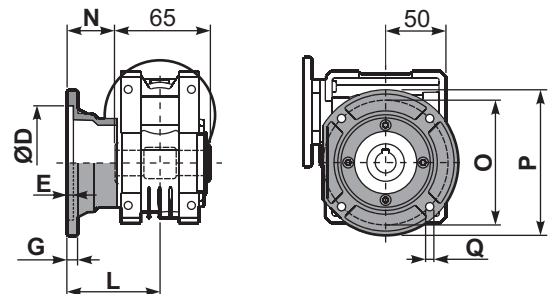

type S	øD	E	G	L	N	O	P	Q	kit code
F1	95H8	5	9	80	47.5	115	140	9.5	KM45.9.012
F2	-	-	-	-	-	-	-	-	-

**PM45FB...** Feet  
Piedini

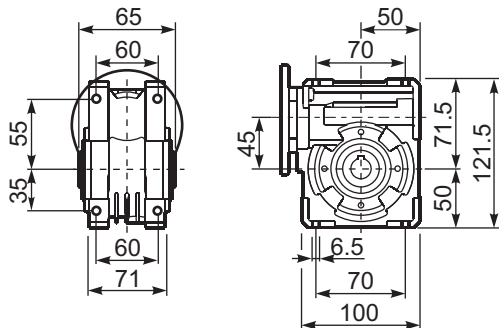

**PM45BR...** Reaction arm  
Braccio di reazione

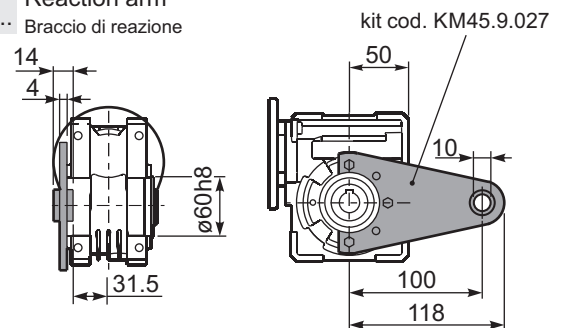

**RM45FB...** Input shaft  
Albero in entrata

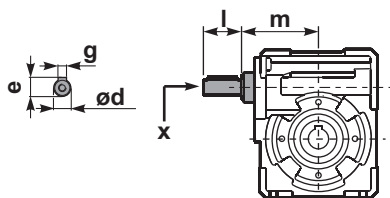

	ød	e	g	l	m	x	kit code
type B	11 h6	12.5	4	30	74	-	① K045.5.006 PAM71 ② -
type S	-	-	-	-	-	-	① - ② -

**PM45.....S...** Single Shaft  
Albero lento semplice

**PM45.....D...** Double Shaft  
Albero lento bisp.

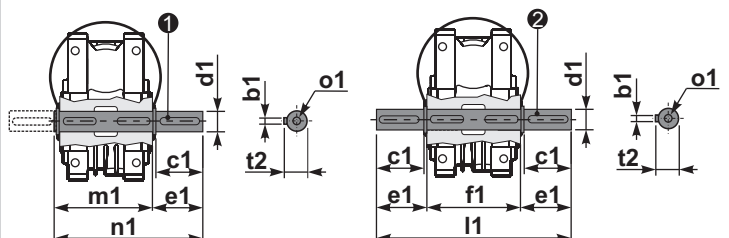

① kit cod. K045.5.028 type B  
kit cod. KS045.5.030 type S  
② kit cod. K045.5.029 type B

	b1	c1	d1	e1	f1	l1	m1	n1	t2	o1
type B	6	32	18 <sup>-0.005</sup> <sub>-0.020</sub>	43	65	151	70	113	20.5	M6x18
type S	6	40	19 <sup>-0.005</sup> <sub>-0.020</sub>	58.5	-	-	70	128.5	21.5	M8x20