



QUICK SELECTION / Selezione veloce

input speed (n_1) = 1400 min⁻¹

Output Speed n_2 [min ⁻¹]	Ratio i	Motor power P_{1M} [kW]	Output torque M_{2M} [Nm]	Service factor f.s.	Nominal power P_{1R} [kW]	Nominal torque M_{2R} [Nm]	Available B5 motor flanges				Available B14 motor flanges			Dynamic efficiency RD	Tooth Module [mm]	Ratios code	
							-C	-D	-E	-F	-R	-T	-U				
							71	80	90	100	80	90	100				112
200	7	4	172	1.1	4.4	190		B	B			B	B		90	3.75	01
140	10	4	240	1.0	3.8	230		B	B			B	B		88	3.75	02
93	15	3	261	1.0	2.9	250		B	B			B	B		85	3.75	03
70	20	2.2	249	1.0	2.2	250		B	B			B	B		83	3.00	04
56	25	1.5	205	1.2	1.8	250	B	B				B			80	2.41	05
45	31	1.5	244	1.1	1.7	270	B	B				B			77	3.75	06
35	40	1.5	295	0.9	1.3	255	B	B				B			72	3.10	07
28	50	0.75	174	1.3	0.96	223	B								68	2.41	08
23	60	0.75	200	1.1	0.80	213	B								65	2.10	09
17.5	80	0.55	177	1.1	0.61	195	B								59	1.53	10
14.0	100	0.55	206	0.8	0.47	175	B								55	1.23	11

A Motor Flanges Available
Flange Motore Disponibili

B Supplied with Reduction Bushing
Fornito con Bussola di Riduzione

B Available on Request without reduction bushing
Disponibile a Richiesta senza Bussola di Riduzione

C Motor Flange Holes Position
Posizione Fori Flangia Motore

EN Unit M75 is supplied with synthetic oil, providing "long life" lubrication. For mounting position V5-V6 please contact us. See table 1 for lubrication and recommended quantity. In table 2 please see possible radial loads and axial loads on the gearbox.

I Il riduttore tipo M75 viene fornito lubrificato a vita con olio sintetico. Per posizioni V5-V6 contattare il ns. servizio tecnico. Vedi tab.1 per oli e quantità consigliati. In tab.2 sono presenti i carichi radiali e assiali applicabili al riduttore.

D Für die Lebensdauerschmierung ist das Getriebe der Größe M75 mit synthetischem Öl befüllt. Bei Einbaulage V5 oder V6 bitten wir um Rücksprache. In Tabelle 1 ist die Schmiermenge und das empfohlene Schmiermittel angegeben. In Tabelle 2 sind die zulässigen Radial- und Axialbelastungen des Getriebes aufgeführt.

F Le réducteur de type M75 est fourni lubrifié à vie avec de l'huile synthétique. Concernant les positions V5.V6, contactez notre service d'assistance technique. Voir tableau 1 concernant les huiles et les quantités conseillées. Les charges radiales et axiales applicables au réducteur sont précisées dans le tableau 2.

E El reductor tamaño M75 se suministra, lubricado de por vida con aceite sintético. Para las posiciones V5 y V6 contactar con nuestro servicio técnico. Ver tabla 1, para cantidades y aceites recomendados. En la tabla 2, se encuentran las cargas radiales y axiales admitidas por el reductor.

LUBRICATION M75 Oil Quantity 0.40 Lt.

SHELL Omala S4 WE 320

ENI Telium VSF 320

For all details on lubrication and plugs check our website

Per maggiori dettagli su lubrificazione e tappi olio vedi il nostro sito web

tab. 1

RADIAL AND AXIAL LOADS

Output shaft

Albero di uscita

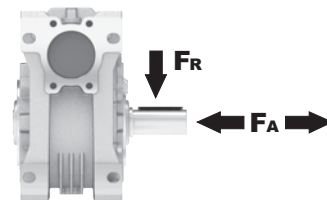

n_2 [min ⁻¹]	FA [N]	FR [N]
200	460	2300
150	520	2600
100	560	2800
75	620	3100
50	720	3600
25	880	4400
15	1000	5000

Input shaft

albero in entrata

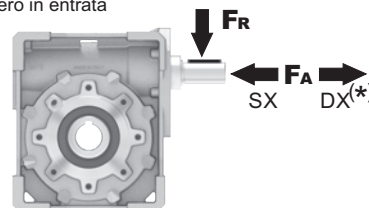

n_1 [min ⁻¹]	FA [N]	FR [N]
1400	125	630

*Strong axial loads in the DX direction are not allowed.
Non sono consentiti forti carichi assiali con direzione DX

tab. 2

PM75**FB**... Basic wormbox
Riduttore base

Gearbox weight
peso riduttore **8.70 kg**

M. flanges	Kit code	øF	A
71B5	K023.4.041	160	114
80/90B5	K023.4.042	200	116
100/112B5	K023.4.043	250	125
80B14	K085.4.046	120	116
90B14	K085.4.045	140	116
100/112B14	K085.4.047	160	125

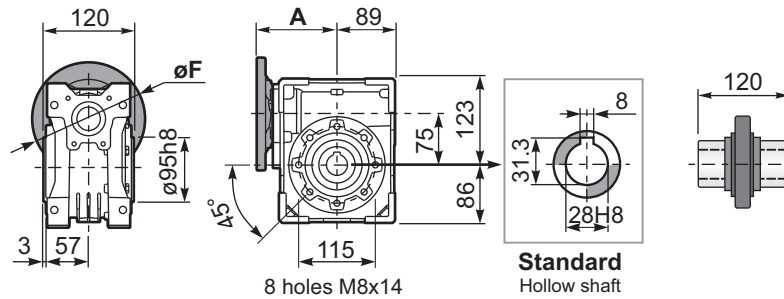

PM75**FC**... Round flange
Flangia rotonda

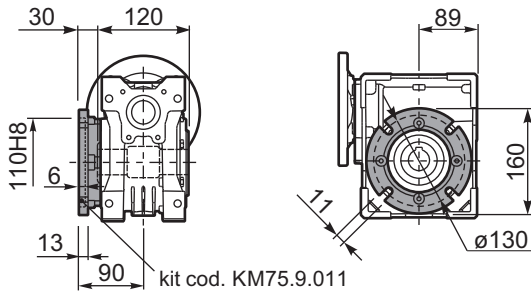

PM75**FL**... Square flange
Flangia quadrata

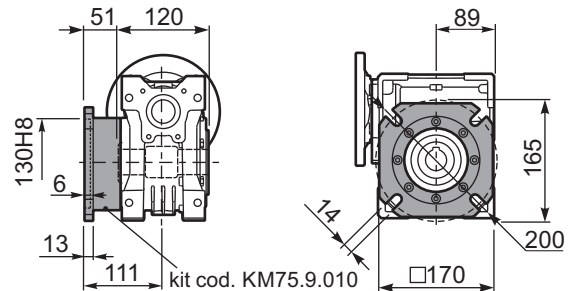

PM75**FB**... Feet
Piedini

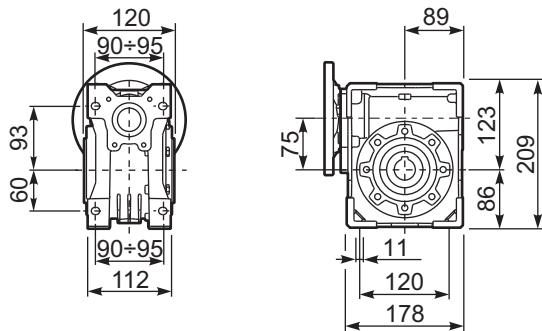

PM75**BR**... Reaction arm
Braccio di reazione

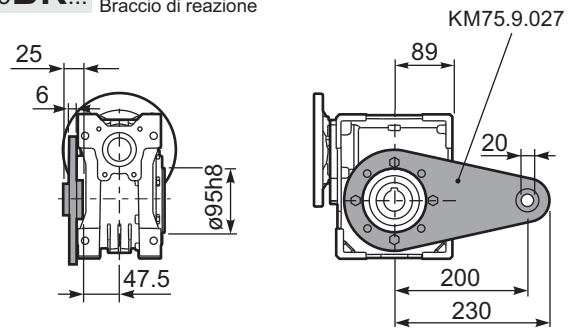

RM75FB... Input shaft
Albero in entrata

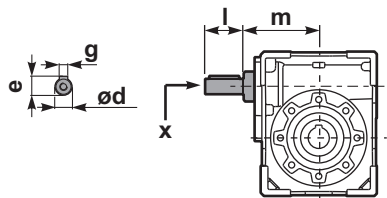

PM75...**S**... Single Shaft
Albero lento semplice

PM75...**D**... Double Shaft
Albero lento bisp.

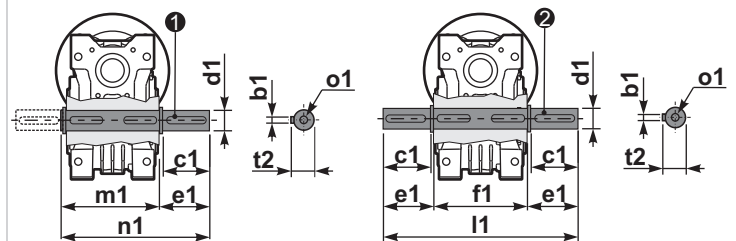

① kit cod. KM75.5.028 Standard

② kit cod. KM75.5.029 Standard

	ød	e	g	l	m	x	kit code
type B	25 h6	27.8	8	50	109.5	M8x20	KQ75.5.006 PAM80 K085.5.007 PAM90 K085.5.008 PAM100

	b1	c1	d1	e1	f1	l1	m1	n1	t2	o1
Standard	8	60	28 h6	63.5	120	247	128.5	192	31	M10
On request	-	-	-	-	-	-	-	-	-	-