



QUICK SELECTION / Selezione veloce

input speed (n_1) = 1400 min⁻¹

| Output Speed n_2 [min ⁻¹] | Ratio i | Motor power P_{1M} [kW] | Output torque M_{2M} [Nm] | Service factor f.s. | Nominal power P_{1R} [kW] | Nominal torque M_{2R} [Nm] | Available B5 motor flanges | | | B14 motor flanges not available | | | | Dynamic efficiency RD | Tooth Module [mm] | Ratios code |
|---|--------------|---------------------------------|-----------------------------------|------------------------|-----------------------------------|------------------------------------|----------------------------|-----|-----|---------------------------------|---|---|---|------------------------------|--------------------------|-----------------|
| | | | | | | | -F | -G | -H | - | - | - | - | | | |
| | | | | | | | 100 | 132 | 160 | - | - | - | - | | | |
| 187 | 7.5 | 15 | 698 | 1.7 | 25.8 | 1200 | | B | | | | | | 91 | 5.5 | 01 |
| 140 | 10 | 15 | 921 | 1.3 | 20.2 | 1240 | | B | | | | | | 90 | 6.155 | 02 |
| 93 | 15 | 11 | 990 | 1.3 | 13.9 | 1250 | | B | | | | | | 88 | 5.5 | 03 |
| 70 | 20 | 11 | 1291 | 1.0 | 11.1 | 1300 | | B | | | | | | 86 | 6.155 | 04 |
| 56 | 25 | 9 | 1289 | 0.9 | 8.4 | 1200 | | B | | | | | | 84 | 5 | 05 |
| 46.7 | 30 | 7.5 | 1274 | 0.9 | 7.1 | 1200 | B | | | | | | | 83 | 4.193 | 06 |
| 35 | 40 | 7.5 | 1596 | 1.0 | 7.3 | 1550 | B | | | | | | | 78 | 6.155 | 07 |
| 28 | 50 | 5.5 | 1426 | 1.0 | 5.4 | 1400 | B | | | | | | | 76 | 5 | 08 |
| 23.3 | 60 | 4 | 1195 | 1.1 | 4.2 | 1260 | B | | | | | | | 73 | 4.193 | 09 |
| 17.5 | 80 | 3 | 1113 | 1.0 | 3.1 | 1150 | | | | | | | | 68 | 3.17 | 10 |
| 14 | 100 | 2.2 | 960 | 1.0 | 2.3 | 1000 | | | | | | | | 64 | 2.55 | 11 |

A) Motor Flanges Available
Flange Motore Disponibili

B) Supplied with Reduction Bushing
Fornito con Bussola di Riduzione

B) Available on Request without reduction bushing
Disponibile a Richiesta senza Bussola di Riduzione

C) Motor Flange Holes Position
Posizione Fori Flangia Motore

EN Unit M15 is supplied without lubricant and equipped with a breather, level and drain plugs. User can add mineral oil keeping existing plugs. Should the user wish to fill it with synthetic oil, it is recommended to replace the existing plugs with a closed plug. See table 1 for lubrication and recommended quantity. In table 2 please see possible radial loads and axial loads on the gearbox.

I Il riduttore tipo M15 è fornito privo di lubrificazione con tappi di sfiato, livello e scarico olio. L'utente può immettere olio minerale mantenendo i tappi esistenti. Se immetterà olio sintetico, dovrà sostituire i tappi esistenti con altri tipo chiuso. Tab.1 per oli e quantità consigliati. Tab.2 carichi radiali e assiali applicabili al riduttore.

D Das Getriebe der Baugröße M15 wird ohne Schmiermittel geliefert. Es ist jedoch mit Einfüllschraube, Überdruckventil und Ablassschraube ausgerüstet. Das benötigte mineralische Öl kann über die Einfüllschraube eingefüllt werden. Sollte synthetisches Öl bevorzugt werden, so ist sind das eingebaute Überdruckventil durch eine geschlossenen Schraube zu ersetzen. In Tabelle 1 ist die Schmiermenge und das empfohlene Schmiermittel angegeben. In Tabelle 2 sind die zulässigen Radial - und Axialbelastungen des Getriebes aufgeführt.

F Le réducteur de type M15 est fourni sans lubrification et avec un bouchon de remplissage, de niveau et d'évacuation de l'huile. L'utilisateur peut y verser de l'huile minérale en conservant les bouchons existants. S'il y versera de l'huile synthétique, il devra substituer les bouchons existants avec d'autres bouchons de type fermé. Voir tableau 1 concernant les huiles et les quantités conseillées. Voir tableau 2 concernant les charges radiales et axiales applicables au réducteur.

E El reductor tamaño M15 se suministra sin lubricante, provisto de tapones de respiración, nivel y descarga de aceite. El usuario puede utilizar aceite mineral, manteniendo los tapones existentes. Si prefiere utilizar aceite sintético deberá sustituir los tapones existentes por tapones ciegos. La prerreducción se suministra con tapones ciegos, lubricado de por vida con aceite sintético. Ver tabla 1, para cantidades y aceites recomendados. En la tabla 2, se encuentran las cargas radiales y axiales admitidas por el reductor.

| B3 | B6 | B7 | B8 | V5 | V6 |
|-----------------------|---------|---------|-----------------|---------|---------|
| | | | | | |
| 7.00 LT | 5.40 LT | 5.40 LT | 5.10 LT | 7.00 LT | 5.10 LT |
| SHELL Omala S2 GX 460 | | | ENI Blasias 460 | | |

For all details on lubrication and plugs check our website **tab. 1**
Per maggiori dettagli su lubrificazione e tappi olio vedi il nostro sito web

RADIAL AND AXIAL LOADS

Output shaft

Albero di uscita

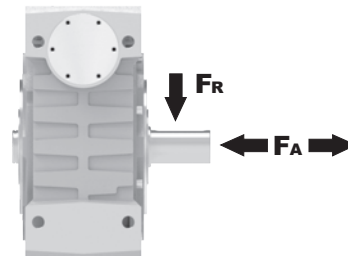

| n_2 [min ⁻¹] | FA [N] | FR [N] |
|-------------------------------|-----------|-----------|
| 200 | 1300 | 6500 |
| 150 | 1440 | 7200 |
| 100 | 1640 | 8200 |
| 75 | 1800 | 9000 |
| 50 | 2120 | 10600 |
| 25 | 2700 | 13500 |
| 15 | 3300 | 16500 |

Input shaft

albero in entrata

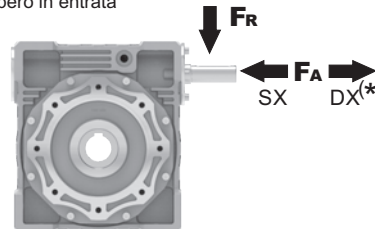

| n_1 [min ⁻¹] | FA [N] | FR [N] |
|-------------------------------|-----------|-----------|
| 1400 | 400 | 2000 |

*Strong axial loads in the DX direction are not allowed.
Non sono consentiti forti carichi assiali con direzione DX

tab. 2

PM15**FB**... Basic wormbox
Riduttore base

Gearbox weight
peso riduttore **84.0 kg**

| M. flanges | Kit code | øF | A |
|------------|------------|-----|-----|
| 100/112B5 | KM15.4.042 | 250 | 210 |
| 132B5 | KM15.4.043 | 300 | 210 |
| 160B5 | KM15.4.044 | 350 | 210 |

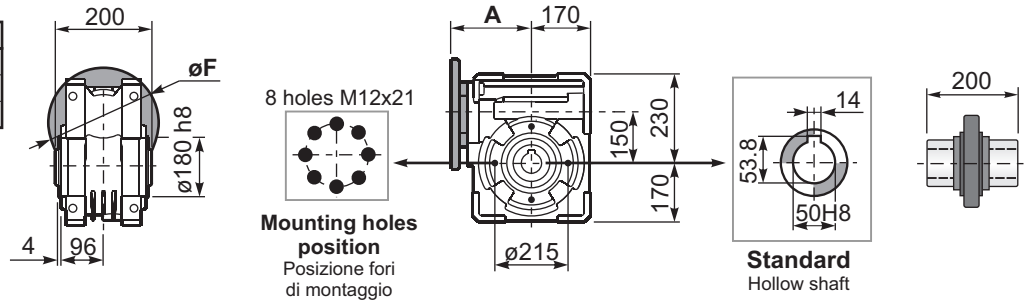

PM15**FC**... Square flange
Flangia quadrata

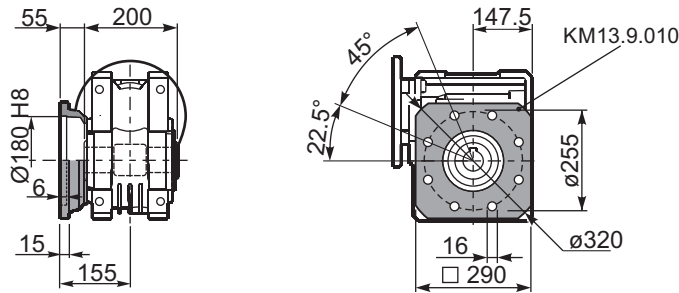

PM15**FB**... Feet
Piedini

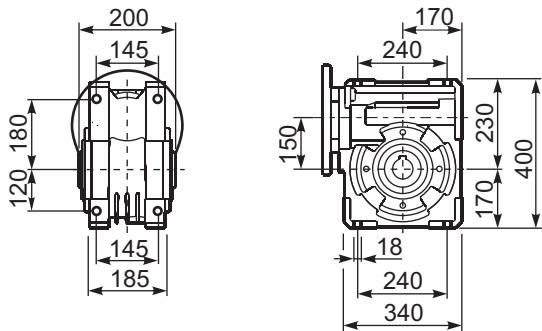

PM15**BR**... Reaction arm
Braccio di reazione

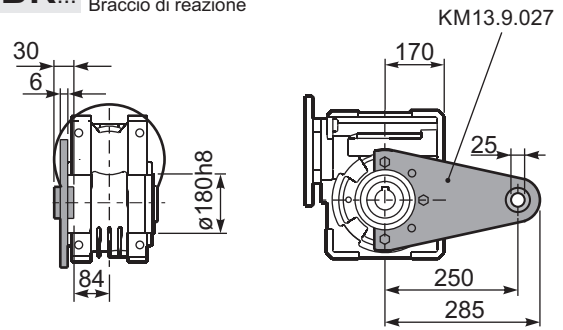

PM15.....**S**... Single Shaft
Albero lento semplice

PM15.....**D**... Double Shaft
Albero lento bisp.

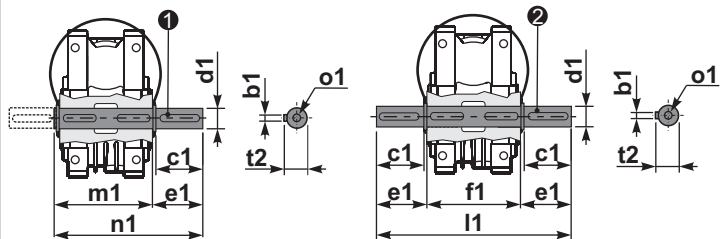

① kit cod. KM15.5.028 type B

② kit cod. KM15.5.029 type B

| | b1 | c1 | d1 | e1 | f1 | l1 | m1 | n1 | t2 | o1 |
|------|----|----|--|----|-----|-----|-----|-----|------|-----|
| type | 14 | 82 | 50 ^{-0.005} _{-0.020} | 87 | 200 | 374 | 210 | 297 | 53.5 | M16 |
| type | - | - | - | - | - | - | - | - | - | - |