

QUICK SELECTION / Selezione veloce

input speed (n_1) = 1400 min⁻¹

Output Speed n_2 [min ⁻¹]	Ratio i	Motor power P_{1M} [kW]	Output torque M_{2M} [Nm]	Service factor f.s.	Nominal power P_{1R} [kW]	Nominal torque M_{2R} [Nm]	Available B5 motor flanges		Available B14 motor flanges		Dynamic efficiency RD	Tooth Module [mm]	Ratios code
							-A	-B	-O	-P			
							56	63	56	63			
5.6	252	0.12	97	1.4	0.17	138	B		B-C		47	2.1	01
3.9	360	0.12	124	1.1	0.13	138	B		B-C		42	2.1	02
2.6	540	0.09	129	1.1	0.10	138	B		B-C		39	2.1	03
1.9	720	0.09	159	0.9	0.08	138	B		B-C		36	2.1	04
1.6	860	0.06	113	1.2	0.07	138	B		B-C		32	1.8	05
1.2	1200	0.06	133	1.0	0.06	138	B		B-C		27	1.3	06
1.0	1440	0.06	153	0.9	0.05	138	B		B-C		26	2.1	07
0.8	1720	0.06	176	0.8	0.05	138	B		B-C		25	1.8	08
0.6	2400	0.06*	132	<0.8	0.04	132	B		B-C		21	1.3	09

A) Motor Flanges Available
Flange Motore Disponibili

B) Supplied with Reduction Bushing
Fornito con Bussola di Riduzione

B) Available on Request without reduction bushing
Disponibile a Richiesta senza Bussola di Riduzione

C) Motor Flange Holes Position
Posizione Fori Flangia Motore

* Power higher than the maximum one which can be supported by the gearbox. Select according to the torque M_{2R}
Potenza superiore a quella massima sopportabile dal riduttore. Selezionare in base al momento torcente M_{2R}

EN Unit **53M** is supplied with synthetic oil, providing "long life" lubrication. For mounting position V5-V6 please contact us.
See table 1 for lubrication and recommended quantity. In table 2 please see possible radial loads and axial loads on the gearbox.

I Il riduttore tipo **53M** viene fornito lubrificato a vita con olio sintetico. Per posizioni V5-V6 contattare il ns. servizio tecnico.
Vedi tab.1 per oli e quantità consigliati. In tab.2 sono presenti i carichi radiali e assiali applicabili al riduttore.

D Für die Lebensdauerschmierung ist das Getriebe der Größe **53M** mit synthetischem Öl befüllt. Bei Einbaulage V5 oder V6 bitten wir um Rücksprache. In Tabelle 1 ist die Schmiermenge und das empfohlene Schmiermittel angegeben. In Tabelle 2 sind die zulässigen Radial- und Axialbelastungen des Getriebes aufgeführt.

F Le réducteur de type **53M** est fourni lubrifié à vie avec de l'huile synthétique. Concernant les positions V5.V6, contactez notre service d'assistance technique. Voir tableau 1 concernant les huiles et les quantités conseillées. Les charges radiales et axiales applicables au réducteur sont précisées dans le tableau 2.

E El reductor tamaño **53M** se suministra, lubricado de por vida con aceite sintético. Para las posiciones V5 y V6 contactar con nuestro servicio técnico. Ver tabla 1, para cantidades y aceites recomendados. En la tabla 2, se encuentran las cargas radiales y axiales admitidas por el reductor.

LUBRICATION 53M Oil
Quantity 0.14/0.03 Lt.

SHELL Omala S4 WE 320	ENI Telium VSF 320
------------------------------	---------------------------

For all details on lubrication and plugs check our website **tab. 1**
Per maggiori dettagli su lubrificazione e tappi olio vedi il nostro sito web

RADIAL AND AXIAL LOADS

Output shaft

Albero di uscita

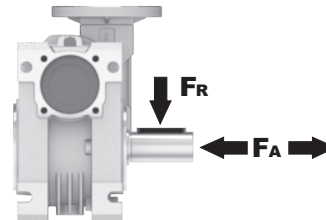

n_2 [min ⁻¹]	FA [N]	FR [N]
25	480	2500
15	560	2800

Input shaft

albero in entrata

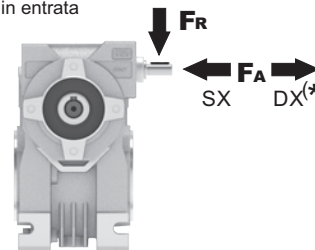

n_1 [min ⁻¹]	FA [N]	FR [N]
1400	20	100

*Strong axial loads in the DX direction are not allowed.
Non sono consentiti forti carichi assiali con direzione DX

tab. 2

P53MFB... Basic wormbox
Riduttore base

M. flanges	Kit code	øF	A
56B5	K030.4.041	120	61.5
63B5	K030.4.042	140	62.5
56B14	K030.4.046	80	61.5
63B14	K030.4.045	90	62.5

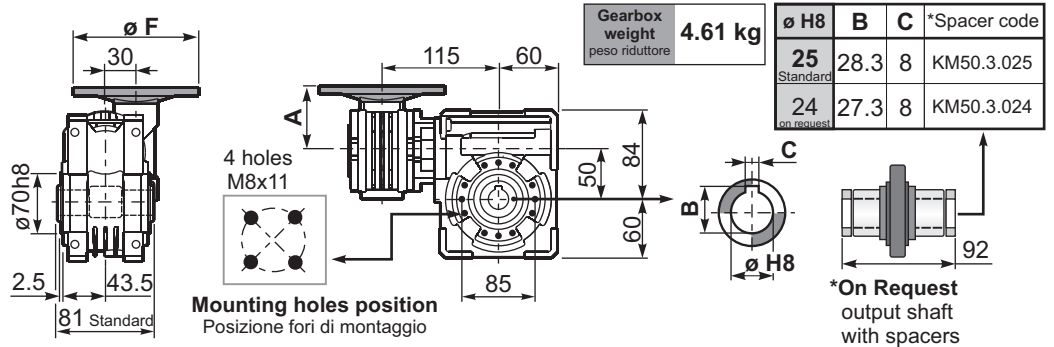

P53MFC... Square flange
Flangia quadrata

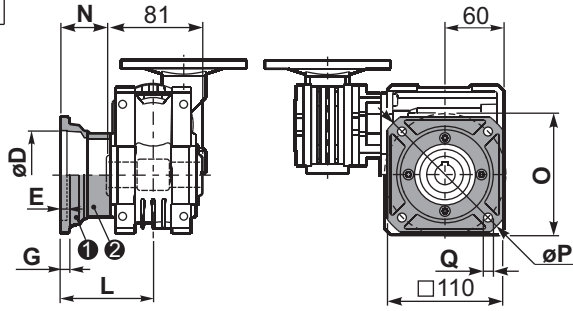

type B	øD	E	G	L	N	O	P	Q	kit code
FC	70 H8	5	9	90	49.5	85	125	11	KM50.9.010
FL	70 H8	5	9	120	79.5	85	125	11	KM50.9.011

P53MF1... Round flange
Flangia rotonda

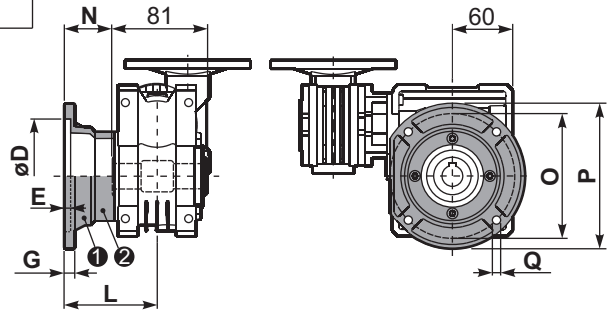

type S	øD	E	G	L	N	O	P	Q	kit code
F1	110 H8	5	10	89	48.5	130	160	9.5	KM50.9.012
F2	95 H8	5	14.5	72	31.5	115	140	11	KM50.9.013

P53MFB... Feet
Piedini

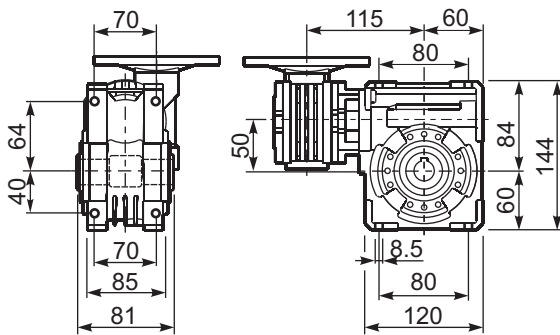

P53MBR... Reaction arm
Braccio di reazione

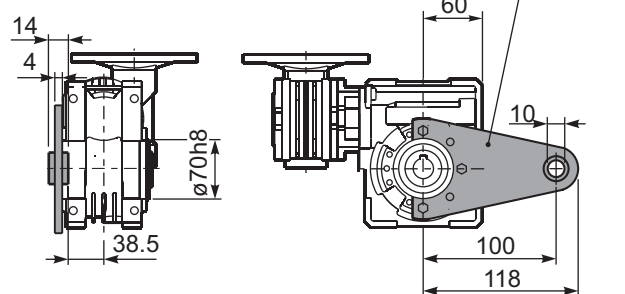

R53MFB... Input shaft
Albero in entrata

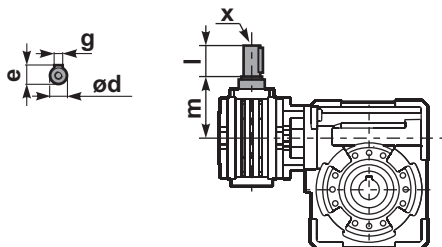

	ød	e	g	l	m	x	kit code
type B	9 h6	10.2	3	20	58	-	K030.5.006 PAM63
type S	-	-	-	-	-	-	-

P53M.....S... Single Shaft
Albero lento semplice

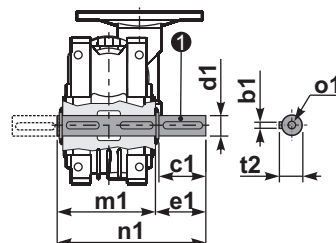

① kit cod. K050.5.028 type B
kit cod. KS050.5.030 type S

P53M.....D... Double Shaft
Albero lento bisp.

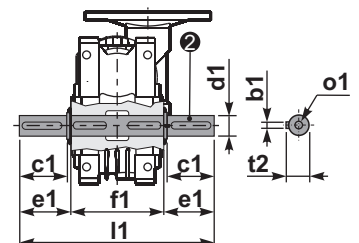

② kit cod. K050.5.029 type B

	b1	c1	d1	e1	f1	l1	m1	n1	t2	ø1
type B	8	52	25 ^{-0.005} _{-0.020}	59.5	81	200	86.5	146	28	M8x20
type S	8	50	24 ^{-0.005} _{-0.020}	68.8	-	-	86.5	155	27	M8x20