

SPM series Stainless steel premium motors

Motori elettrici in acciaio inox

Section **2**
Sezione 2



Full stainless steel electric motors ideal for extreme conditions.

Motore elettrico completamente in acciaio inox adatto per condizioni estreme.



Standard terminal box with cable gland in **axial** position



On request terminal box with cable gland in **radial** position

For the complete documentations please visit our web site: www.cleangeartech.com

Per la documentazione completa si prega di visitare il nostro sitoweb: www.cleangeartech.com

The SPM Series Hygienic stainless steel electric motors



Standard terminal box with cable gland in axial position

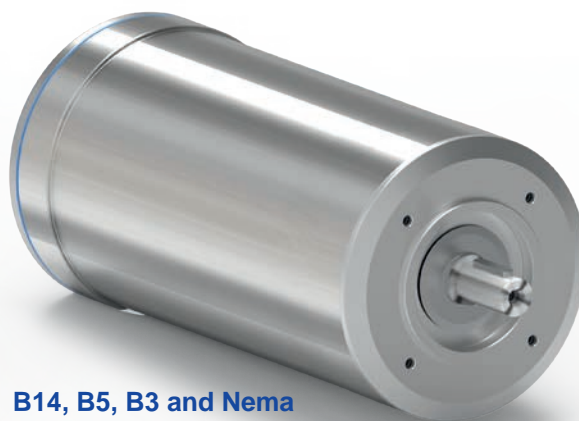

B14, B5, B3 and Nema Stainless steel premium motors

The SPM Series

It is ideal for extreme conditions.

Smooth surfaces and stainless steel are the ideal solutions where the hygienic requirements are strict, like in the Food and Beverage Industry, in order to avoid bacterial contamination. The motor is easy to clean, resistant to rust and corrosion. The IP69K rating provides ultimate protection against high pressure (100 bar) hot water (80°C) sprays. Meat&poultry, dairy, seafood equipments are very demanding in terms of corrosion resistance: our motors can face these challenges. Totally Enclosed Non-Ventilated IC410 (TENV), hygienic smooth surfaces: no ribs, no fins. Die cast aluminum rotor, precision balanced G2,5 according to ISO1940-1 2003.

La serie SPM

La serie SPM è la soluzione ideale dove le esigenze di igiene sono stringenti come nell'industria del Cibo e delle Bevande, per evitare la contaminazione batterica. Il motore è facile da pulire, resistente alla ruggine e alla corrosione.

Il grado di protezione IP69K garantisce la massima protezione contro i getti di acqua calda (80°C) ad alta pressione (100 bar).

Le macchine e gli impianti dell'industria della carne/pollame, casearia e del pesce/frutti di mare sono molto esigenti in termini di resistenza alla corrosione: i nostri motori possono affrontare queste sfide.

Cassa e coperchi in acciaio inox, totalmente chiuso non ventilato IC410 (TENV), superfici lisce igieniche: senza alettatura.

Rotore alluminio pressofuso, bilanciato con precisione G2,5 in accordo a ISO1940-1 2003.

SPM certification

electric motors



IEC Asynchronous three-phase 230/400V 50Hz.

TENV (totally enclosed non ventilated).

TEFC (totally enclosed fan cooled) IEC only 2.2 kW 4P and 3kW 6P.

IEC Asincroni trifase 230/400V 50Hz.

TENV (totalmente chiuso non ventilato).

TEFC (totalmente chiuso ventilato) IEC solo 2.2 kW 4P e 3kW 6P.

Standard terminal box with cable gland in axial position.

On request terminal box with cable gland in radial position.

Standard morsetti con pressacavo in posizione assiale.

A richiesta morsetti con pressacavo in posizione radiale.

IEC Sizes Taglie IEC	63, 71, 80, 90, 100
Power Potenza	0.12 ÷ 3.0 kW
Mounting Montaggio	B14, B5, B3
Poles Poli	2, 4, 6

THE BEST PROTECTION IN 316L

NBR oil seal on the shaft

Anelli di tenuta in NBR sull'albero.

Options Double seal

Opzione doppio anello di tenuta

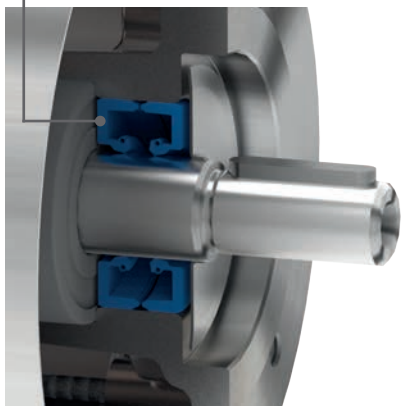

Extra protection

Flinger for extra protection against high pressure water spray.

Disco di protezione contro i getti d'acqua ad alta pressione.



Bearings

Double sealed with grease lubricated.

Cuscinetti schermati e lubrificati a grasso.

AISI 420 Stainless steel shaft

Albero in acciaio inox AISI 420.

O-ring and seal to prevent water entry.
Blue seal.

O-ring e guarnizione per prevenire l'ingresso di acqua.
Guarnizione blu.

Standard Hygienic cable gland



Standard pressacavo dal design igienico.

Options Anti condensation cable gland



Stainless steel cable gland with pressure compensation.

Pressacavo in acciaio inox con compensazione della pressione.

Options PTC thermistors

The PTC thermistor can be used to protect motors from overload once a certain temperature has been exceeded.

La sonda termistore PTC è può essere utilizzata per proteggere i motori dal sovraccarico una volta superata una certa temperatura.



PTO thermal protection

PTO thermal protection. Easy and stable connection with terminal block inside back conduit box.

Inverter spike resistant Class F insulation system allows operation on adjustable speed drives.

Protezione termica PTO.

Collegamento semplice e stabile grazie alla morsetteria all'interno del coperchio posteriore. Sistema di isolamento classe F resistente ai picchi di corrente istantanea dovuti all'uso dell'inverter, consente l'utilizzo con sistemi di regolazione della velocità.

Options Encapsulated motor

Stator covered with resin to protect all parts of the motor by isolating them electrically and making the winding completely protected from any liquid.

Statore ricoperto con resina per proteggere tutte le parti del motore isolandole elettricamente e rendendo l'avvolgimento protetto da ogni liquido.



Options Cable gland in radial position

Stainless steel hygienic cable gland in radial position

Pressacavo igienico in acciaio inox in posizione radiale.



Options Pre-heater

With high humidity (RH>60%) or with low ambient temperature (T<-20°C), can be equipped with an anticondensation heater to be used when motor is switched off. Supplied with single phase 230V 50Hz.

Con umidità elevata (>60%) o con temperatura ambiente bassa (<-20°C), possono essere dotati di resistenza anticondensa, da utilizzare quando il motore è spento. Alimentato a 230V 50Hz monofase.

