

Input speed (n_1) = 1400 min⁻¹

Output speed n_2 [min ⁻¹]	Ratio i	Motor power P_{1M} [kW]	Output torque M_{2M} [Nm]	Service factor $f.s$	Nominal power P_{1R} [kW]	Nominal torque M_{2R} [Nm]	B5 motor flanges				B14 motor flanges			Dynamic efficiency RD	Tooth module [mm]	Ratio code	
							-B 63	-C 71	-D 80	-E 90	-Q 71	-R 80	-T 90				
200	7	1.8	71	1.8	3.2	125		B	B			B-C	B-C		83	3.1	01
140	10	1.8	99	1.4	2.4	134		B	B			B-C	B-C		81	3.1	02
93	15	1.5	121	1.1	1.7	138		B	B			B-C	B-C		79	3.1	03
74	19	1.1	111	1.2	1.4	138		B	B			B-C	B-C		78	2.6	04
58	24	1.1	135	1.0	1.2	142		B	B			B-C	B-C		75	2.0	05
47	30	1.1	167	0.9	0.96	146		B	B			B-C	B-C		74	3.2	06
39	36	0.75	125	1.2	0.88	147		B	B			B-C	B-C		68	2.7	07
35	40	0.75	135	1.0	0.78	140		B	B	B		B-C	B-C		66	2.5	13
31	45	0.55	111	1.2	0.67	135	B	B				B-C	C		66	2.1	08
23	60	0.55	140	0.9	0.51	130	B	B				B-C	C		62	1.6	12
21	67	0.55	151	0.8	0.45	124	B	B				B-C	C		60	1.5	09
17.5	80	0.37	115	1.0	0.38	119	B	B				B-C	C		57	1.3	10
14.9	94	0.37	123	1.0	0.36	119	B	B				B-C	C		52	1.1	11

Motor flanges available
Flange motore disponibili



B) Supplied with reduction bushing
Fornito con bussola di riduzione



B) Available on request without reduction bushing
Disponibile a richiesta senza bussola di riduzione



C) Motor flange holes position
Posizione fori flangia motore

Lubrication

Lubrificazione

Unit D63 is supplied with synthetic oil to assure long life lubrication. Food grade oil is available on request.

See Table 1 for lubrication and recommended quantity.

See Table 2 for possible radial and axial loads on the gearbox.

Il riduttore tipo D63 viene fornito con olio sintetico e lubrificazione tipo "long life". Disponibile a richiesta olio alimentare.

Vedi Tabella 1 per oli e quantità consigliati.

Vedi Tabella 2 per i carichi radiali e assiali applicabili al riduttore.

Oil quantity for all positions: 0.40 L	Shell	Eni
Quantità olio per tutte le posizioni: 0.40 L	Omala S4 WE 320	Telium VSF 320

Tab. 1

Suggested

Suggerito

Stainless steel protection cap (on request).

Coperchio di protezione in acciaio inox a richiesta.

Kit cod. KN630209

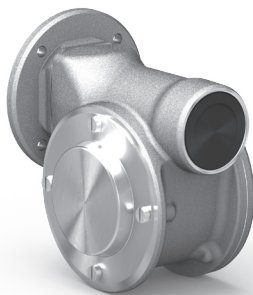

Radial and axial loads

Carichi radiali e assiali

Output shaft

Albero di uscita

n_2 [min ⁻¹]	FA [N]	FR [N]
200	360	1800
150	400	2000
100	460	2300
75	500	2500
50	600	3000
25	700	3800
15	800	4000

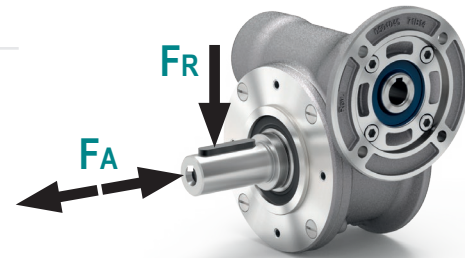

Input shaft

Albero in entrata

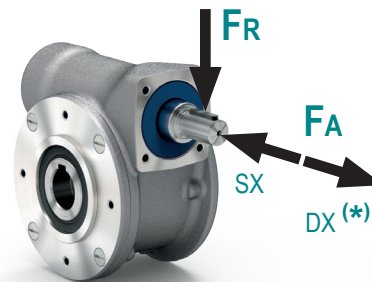

n_1 [min ⁻¹]	FA [N]	FR [N]
1400	90	450

* Strong axial loads in the DX direction are not allowed.

* Non sono consentiti forti carichi assiali con direzione DX

Tab. 2

PD63 **UNI..** Basic gearbox
Riduttore base

M. flanges	Kit code	øF	A
63B5	KD634041	140	99.5
71B5	KD634042	160	97.5
80/90B5	KD634043	200	99.5
71B14	KD634047	105	97.5
80B14	KD634046	120	99.5
90B14	KD634041	140	99.5

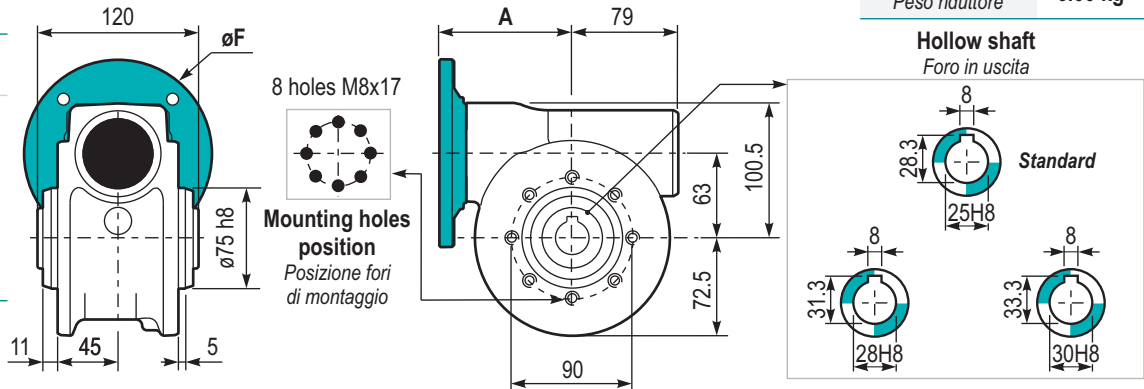

Gearbox weight
Peso riduttore 6.00 kg

Hollow shaft
Foro in uscita

PD63 **PA..** Feet
Piedini

Type	T	Kit code
B**	144	K0639022
I*	130	KN639022

** Zink plated
* Stainless steel

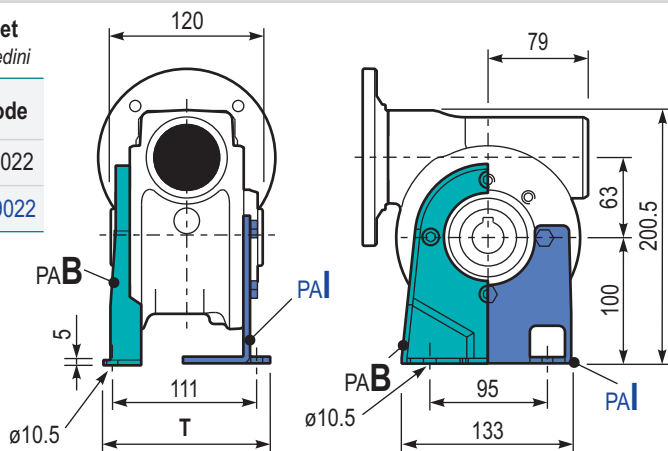

PD63 **PBB..** Feet
Piedini

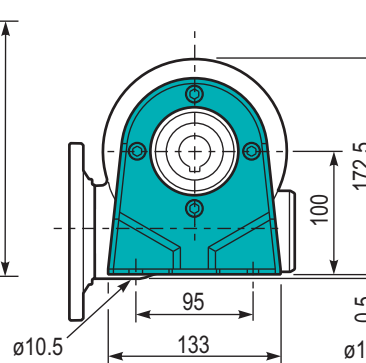

PD63 **PV..** Feet
Piedini

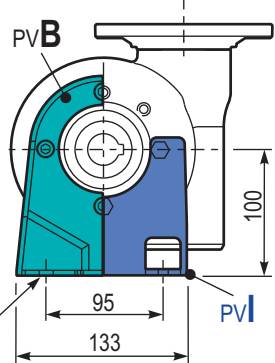

PD63 **FL..** Output flange
Flangia uscita

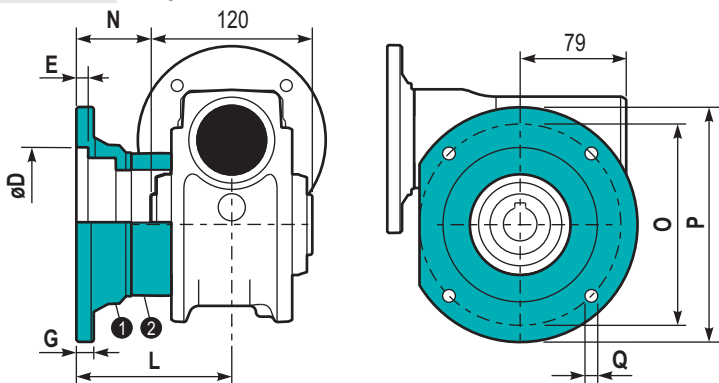

Type	øD	E	G	L	N	O	P	Q	Kit code
C	115 ^{+0.20} _{+0.15}	7	13	86	26	150	175	11	① K0639010 ② -
L	115 ^{+0.20} _{+0.15}	7	13	116	56	150	175	11	① K0639010 ② K0630200

PD63 **BR..** Reaction arm
Braccio di reazione

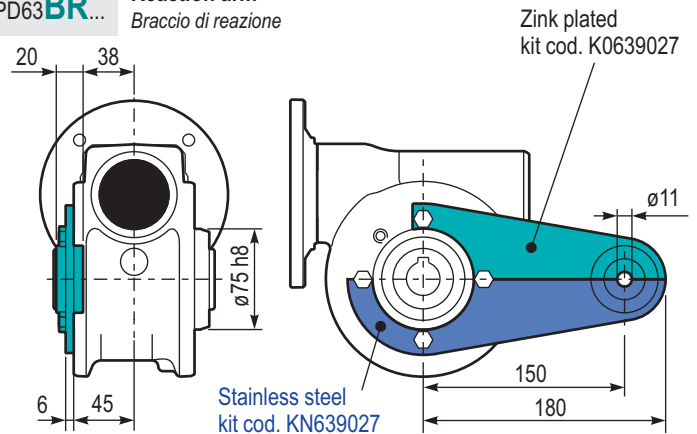

RD63 **UNI..** Input shaft
Albero in entrata

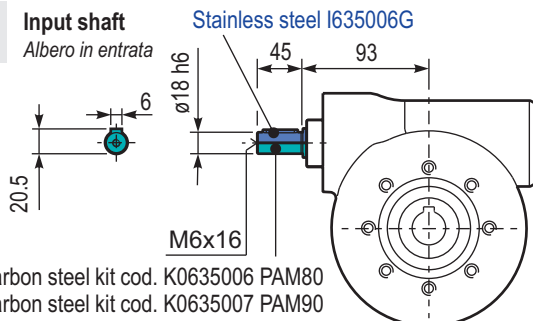

PD63.. **SMF** Single output shaft
Albero semplice in uscita

