

Z30

21 Nm

VFZ series

Aluminum worm gearboxes (NTT treatment)

Riduttori a vite senza fine in alluminio (trattamento NTT)

Input speed (n_1) = 1400 min⁻¹

Output speed n_2 [min ⁻¹]	Ratio i	Motor power P_{1M} [kW]	Output torque M_{2M} [Nm]	Service factor f_s	Nominal power P_{1R} [kW]	Nominal torque M_{2R} [Nm]	B5 motor flanges		B14 motor flanges		Dynamic efficiency RD	Tooth module [mm]	Ratio code
							-	-	-O 56	-P 63			
280	5	0.18	5	3.3	0.60	17			B-C		82	1.26	09
200	7	0.18	7	2.4	0.44	17			B-C		80	1.44	01
140	10	0.18	10	1.8	0.32	17			B-C		78	1.44	02
93	15	0.18	13	1.4	0.25	19			B-C		73	1.44	03
70	20	0.18	17	1.1	0.20	19			B-C		70	1.09	04
47	30	0.12	15	1.4	0.17	21			B-C		62	1.44	05
35	40	0.12	19	1.1	0.13	20			B-C		57	1.09	06
23	61	0.09	19	1.1	0.10	20			B-C		50	0.72	07
17.5	80	0.06	16	1.0	0.06	16			B-C		48	0.56	08
14	100	0.06*	16	0.5	0.03	8			B-C		40	0.45	10

* Power higher than the maximum one which can be supported by the gearbox. Select according to the torque M_{2R}

Potenza superiore a quella massima sopportabile dal riduttore. Selezionare in base al momento torcente M_{2R}

Motor flanges available
Flange motore disponibili



B) Available on request without reduction bushing
Disponibile a richiesta senza bussola di riduzione



C) Motor flange holes position
Posizione fori flangia motore

Lubrication

Lubrificazione

Unit Z30 is supplied with synthetic oil to assure long life lubrication. Food grade oil is available on request.

See Table 1 for lubrication and recommended quantity.

See Table 2 for possible radial and axial loads on the gearbox.

Il riduttore tipo Z30 viene fornito con olio sintetico e lubrificazione tipo "long life".

Disponibile a richiesta olio alimentare.

Vedi Tabella 1 per oli e quantità consigliati.

Vedi Tabella 2 per i carichi radiali e assiali applicabili al riduttore.

Oil quantity for all positions:
0.025Lt.

Quantità olio per tutte le posizioni: 0.025Lt.

Agip
Telium VSF 320

Shell
Omala S4 WE 320

Tab. 1

Suggested

Suggerito

Stainless steel protection cap (on request).

Coperchio di protezione in acciaio inox a richiesta.



Kit cod. KN300209

Radial and axial loads

Carichi radiali e assiali

Output shaft

Albero di uscita

n_2 [min ⁻¹]	F_A [N]	F_R [N]
200	120	600
150	140	700
100	160	800
75	180	900
50	200	1000
25	250	1250
15	280	1400

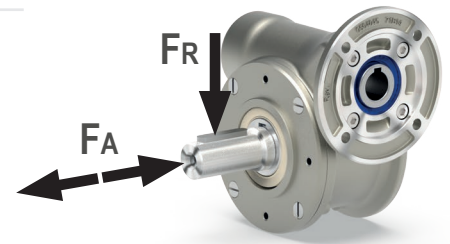

Input shaft

Albero in entrata

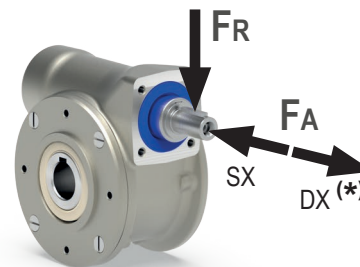

n_1 [min ⁻¹]	F_A [N]	F_R [N]
1400	20	100

* Strong axial loads in the DX direction are not allowed.

* Non sono consentiti forti carichi assiali con direzione DX

Tab. 2

PZ30UNI.. Basic gearbox
Riduttore base

Gearbox weight 1.25 kg
Peso riduttore

M. flanges	Kit code	øF	A
56B14	KZ304046	80	62
63B14	KZ304045	90	63

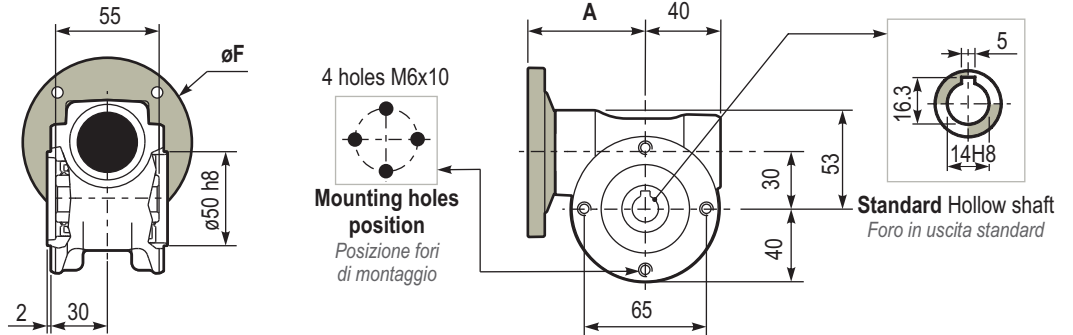

PZ30PAI.. Feet
Piedini

kit cod. KN309022

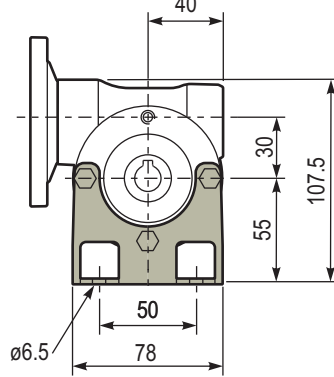
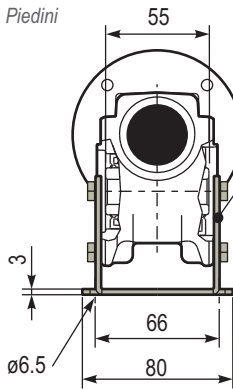

PZ30PVI.. Feet
Piedini

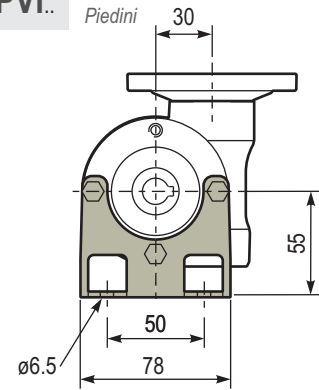

PZ30FL.. Output flange
Flangia uscita

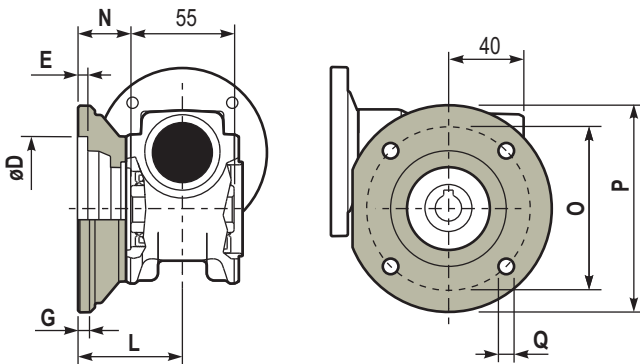

PZ30BRI.. Reaction arm
Braccio di reazione

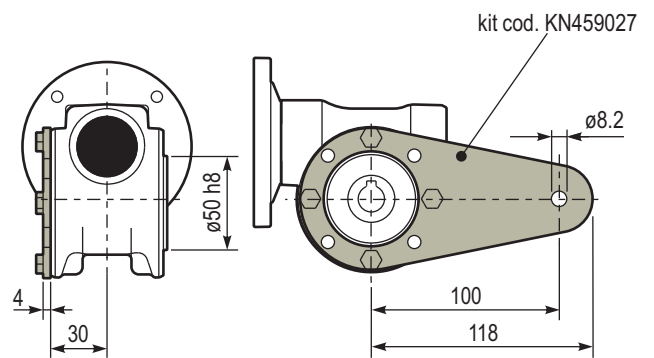

Type	øD	E	G	L	N	O	P	Q	Kit code
C	50 ^{+0.15} / _{+0.05}	6	6	50.5	23	68	80	7	KZ309010
L	60 ^{+0.15} / _{+0.05}	6	6	55.5	28	87	110	8.5	KZ459010

PZ30..SMS Single output shaft
Albero semplice in uscita

kit cod. KI0305028

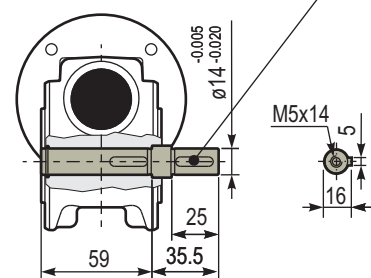

RZ30UNI.. Input shaft
Albero in entrata

