

**TR FRENLİ MOTOR ADAPTÖRÜ**

Aşağıdaki tablolar PL, PLB planet dişli ünitelerinde akuple girişli EDF, EF uygulamalarını göstermektedir.

**EN DIRECT INPUT MOTOR ADAPTOR WITH BRAKE**

The following tables show how to apply direct inputs EDF, EF on PL, PLB planetary gear units.

**DE MOTORFLANSCH MIT INTEGRIERTER BREMSE**

Die nachfolgenden Tabellen zeigen die Anbaumöglichkeiten der EF - und EDF - Antriebe an die Getriebe der Serien PL und PLB.

**IT ENTRATE DIRETTE CON FRENO E ATTACCO MOTORE**



Le tabelle seguenti indicano l'applicabilità delle entrate dirette EDF, EF sui riduttori PL, PLB.



**FR ENTRÉE DIRECTE AVEC FREIN POUR ADAPTATION MOTEUR**

Le tabelle seguenti indicano l'applicabilità delle entrate dirette EDF, EF sui riduttori PL, PLB.

**ES ENTRADAS DIRECTAS CON FRENO PARA ACOPLAMIENTO MOTOR**

Las siguientes tablas indican la factibilidad de aplicación de las entradas directas EDF, EF en los reductores PL, PLB.

		
	EDF	ED
PL 1000	1-2-3-4	—
PL 1600	1-2-3-4	—
PL 2500	2-3-4	1
PL 5000	2-3-4	1
PL 7000	3-4	2
PL 10000	3-4	2
PL 16000	3-4	2
PL 18000	4	3
PL 25000	4	3
PL 30000	4	3
PL 35000	4	3
PL 50000	4	3
PL 65000	—	4
PL 90000	—	4
PL 130000	5	4
PL 170000	5	4
PL 220000	5	4
PL 250000	—	5
PL 300000	—	5
PL 380000	—	5
PL 460000	—	5
PL 550000	—	5
PL 620000	—	—

		
	EF	
PLB 1000	2-3-4	
PLB 1600	2-3-4	
PLB 2500	2-3-4	
PLB 5000	2-3-4	
PLB 7000	2-3-4	
PLB 10000	2-3-4	
PLB 16000	3-4	
PLB 18000	3-4	
PLB 25000	3-4	
PLB 30000	3-4	
PLB 35000	4	
PLB 50000	4	
PLB 65000	4	
PLB 90000	4	
PLB 130000	4-5	
PLB 170000	5	
PLB 220000	5	
PLB 250000	5	
PLB 300000	5	
PLB 380000	—	
PLB 460000	—	
PLB 550000	—	
PLB 620000	—	

**Not:** 1-2-3-4-5 rakamları planet dişli ünitesinin kede-me sayısını göstermektedir.

**N.B.:** Numbers 1-2-3-4-5 refer to the number of stages of the planetary gear unit.

**N.B.:** Die Ziffern 1-2-3-4-5 geben die Anzahl der Getriebestufen an.

**N.B.:** i numeri 1-2-3-4-5 indicano il numero di stadi dei riduttori.

**N.B.:** Les numéros 1-2-3-4-5 indiquent le nombre d'étages des réducteurs.

**Nota:** Los números 1-2-3-4-5 indican el número de etapas de los reductores.

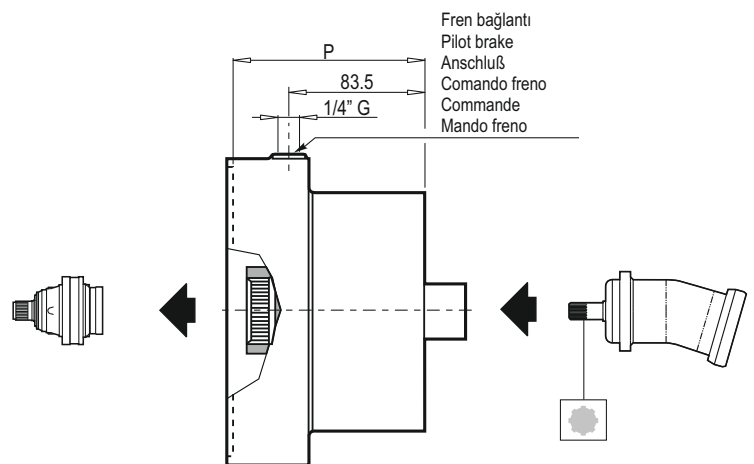

EDF								
	Cfs <sub>min</sub> [Nm]	Pa <sub>min</sub> [bar]	P	Kod / Code Bestell Nr. / Codice Code / Código	P <sub>max</sub> [bar]	OIL [lt]		Kg
						V1	B5	
EDF 10 per/for GLC-OMSS-HPRC	110	13	118	8074.100.710	300	0.3	0.15	20
EDF 16 per/for GLC-OMSS-HPRC	160	17	118	8074.101.710				
EDF 20 per/for GLC-OMSS-HPRC	220	23	118	8074.102.710				
EDF 25 per/for GLC-OMSS-HPRC	260	17	118	8074.103.710				
EDF 35 per/for GLC-OMSS-HPRC	360	17	118	8074.104.710				
EDF 45 per/for GLC-OMSS-HPRC	470	23	118	8074.105.710				
EDF 55 per/for GLC-OMSS-HPRC	600	27	118	8074.106.710				

EDF								
	Cfs <sub>min</sub> [Nm]	Pa <sub>min</sub> [bar]	P	Kod / Code Bestell Nr. / Codice Code / Código	P <sub>max</sub> [bar]	OIL [lt]		Kg
						V1	B5	
EDF 10 per/for EATON 2000 BEARINGLESS	110	13	118	İstenirse On request Auf Anfrage A richiesta Sur demande Bajo demanda	300	0.3	0.15	20
EDF 16 per/for EATON 2000 BEARINGLESS	160	17	118					
EDF 20 per/for EATON 2000 BEARINGLESS	220	23	118					
EDF 25 per/for EATON 2000 BEARINGLESS	260	17	118					
EDF 35 per/for EATON 2000 BEARINGLESS	360	17	118					
EDF 45 per/for EATON 2000 BEARINGLESS	470	23	118					
EDF 55 per/for EATON 2000 BEARINGLESS	600	27	118					

**TR FRENLİ MOTOR ADAPTÖRÜ**

Aşağıdaki tablolar PL, PLB planet dişli ünitelerinde akuple girişli EDF, EF uygulamalarını göstermektedir.

**EN DIRECT INPUT MOTOR ADAPTOR WITH BRAKE**

The following tables show how to apply direct inputs EDF, EF on PL, PLB planetary gear units.

**DE MOTORFLANSCH MIT INTEGRIERTER BREMSE**

Die nachfolgenden Tabellen zeigen die Anbaumöglichkeiten der EF - und EDF - Antriebe an die Getriebe der Serien PL und PLB.

**IT ENTRATE DIRETTE CON FRENO E ATTACCO MOTORE**

Le tabelle seguenti indicano l'applicabilità delle entrate dirette EDF, EF sui riduttori PL, PLB.

**FR ENTRÉE DIRECTE AVEC FREIN POUR ADAPTATION MOTEUR**

Le tabelle seguenti indicano l'applicabilità delle entrate dirette EDF, EF sui riduttori PL, PLB.

**ES ENTRADAS DIRECTAS CON FRENO PARA ACOPLAMIENTO MOTOR**

Las siguientes tablas indican la factibilidad de aplicación de las entradas directas EDF, EF en los reductores PL, PLB.

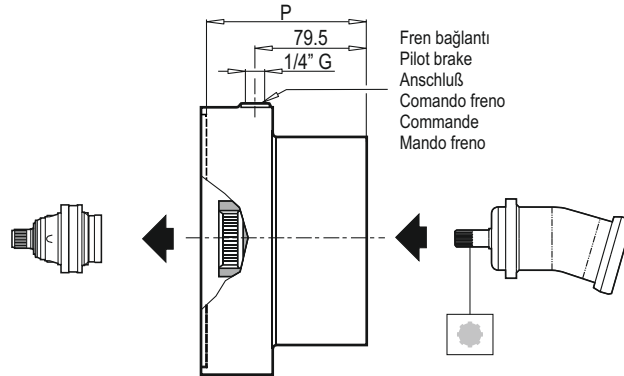

EDF								
	Cfs <sub>min</sub> [Nm]	Pa <sub>min</sub> [bar]	P	Kod / Code Bestell Nr. / Codice Code / Código	P <sub>max</sub> [bar]	OIL [lt]		Kg
						V1	B5	
EDF 10 SAE A 2-4 F 16/32 DP 9TH	110	13	114	İstenirse On request Auf Anfrage A richiesta Sur demande Bajo demanda	300	0.3	0.15	20
EDF 16 SAE A 2-4 F 16/32 DP 9TH	160	17	114					
EDF 20 SAE A 2-4 F 16/32 DP 9TH	220	23	114					
EDF 25 SAE A 2-4 F 16/32 DP 9TH	260	17	114					
EDF 25 SAE A 2-4 F 16/32 DP 9TH	360	17	114					
EDF 45 SAE A 2-4 F 16/32 DP 9TH	470	23	114					
EDF 55 SAE A 2-4 F 16/32 DP 9TH	600	27	114					

EDF								
	Cfs <sub>min</sub> [Nm]	Pa <sub>min</sub> [bar]	P	Kod / Code Bestell Nr. / Codice Code / Código	P <sub>max</sub> [bar]	OIL [lt]		Kg
						V1	B5	
EDF 10 SAE A 2-4 F 16/32 DP 13TH	110	13	114	İstenirse On request Auf Anfrage A richiesta Sur demande Bajo demanda	300	0.3	0.15	20
EDF 16 SAE A 2-4 F 16/32 DP 13TH	160	17	114					
EDF 20 SAE A 2-4 F 16/32 DP 13TH	220	23	114					
EDF 25 SAE A 2-4 F 16/32 DP 13TH	260	17	114					
EDF 35 SAE A 2-4 F 16/32 DP 13TH	360	17	114					
EDF 45 SAE A 2-4 F 16/32 DP 13TH	470	23	114					
EDF 55 SAE A 2-4 F 16/32 DP 13TH	600	27	114					

EDF								
	Cfs <sub>min</sub> [Nm]	Pa <sub>min</sub> [bar]	P	Kod / Code Bestell Nr. / Codice Code / Código	P <sub>max</sub> [bar]	OIL [lt]		Kg
						V1	B5	
EDF 10 SAE A 2-4 F 12/24 DP 14TH	110	13	114	İstenirse On request Auf Anfrage A richiesta Sur demande Bajo demanda	300	0.3	0.15	20
EDF 16 SAE A 2-4 F 12/24 DP 14TH	160	17	114					
EDF 20 SAE A 2-4 F 12/24 DP 14TH	220	23	114					
EDF 25 SAE A 2-4 F 12/24 DP 14TH	260	17	114					
EDF 35 SAE A 2-4 F 12/24 DP 14TH	360	17	114					
EDF 45 SAE A 2-4 F 12/24 DP 14TH	470	23	114					
EDF 55 SAE A 2-4 F 12/24 DP 14TH	600	27	114					

EDF								
	Cfs <sub>min</sub> [Nm]	Pa <sub>min</sub> [bar]	P	Kod / Code Bestell Nr. / Codice Code / Código	P <sub>max</sub> [bar]	OIL [lt]		Kg
						V1	B5	
EDF 10 SAE A 2-4 F 1" 6B	110	13	114	8074.080.710	300	0.3	0.15	20
EDF 16 SAE A 2-4 F 1" 6B	160	17	114	8074.081.710				
EDF 20 SAE A 2-4 F 1" 6B	220	23	114	8074.082.710				
EDF 25 SAE A 2-4 F 1" 6B	260	17	114	8074.083.710				
EDF 35 SAE A 2-4 F 1" 6B	360	17	114	8074.084.710				
EDF 45 SAE A 2-4 F 1" 6B	470	23	114	8074.085.710				
EDF 55 SAE A 2-4 F 1" 6B	600	27	114	8074.086.710				

**TR** FRENLİ MOTOR ADAPTÖRÜ  
**IT** ENTRATE DIRETTE CON FRENO E ATTACCO MOTORE

**EN** DIRECT INPUT MOTOR ADAPTOR WITH BRAKE  
**FR** ENTRÉE DIRECTE AVEC FREIN POUR ADAPTATION MOTEUR

**DE** MOTORFLANSCH MIT INTEGRIERTER BREMSE  
**ES** ENTRADAS DIRECTAS CON FRENO PARA ACOPLAMIENTO MOTOR

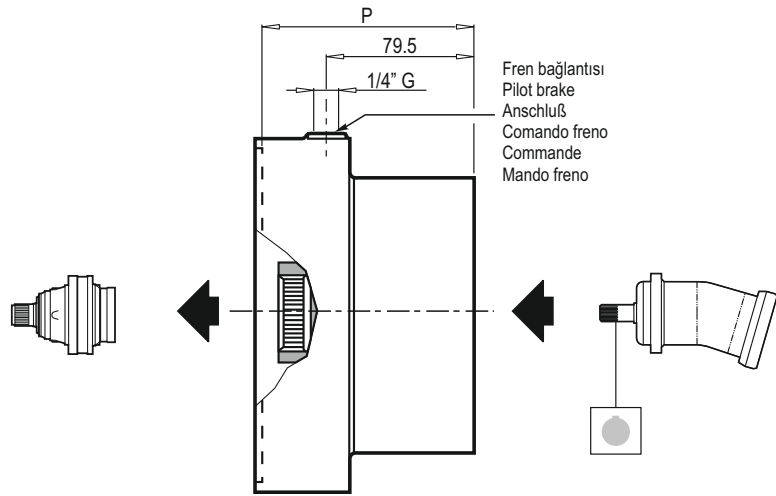

EDF								
Icon	Cfs <sub>min</sub> [Nm]	Pa <sub>min</sub> [bar]	P	Kod / Code Bestell Nr. / Codice Code / Código	P <sub>max</sub> [bar]	OIL [lt]		Kg
						V1	B5	
EDF 10 SAE A 2-4 F D. 25 CH 8	110	13	114	8074.010.710	300	0.3	0.15	20
EDF 16 SAE A 2-4 F D. 25 CH 8	160	17	114	8074.011.710				
EDF 20 SAE A 2-4 F D. 25 CH 8	220	23	114	8074.012.710				
EDF 25 SAE A 2-4 F D. 25 CH 8	260	17	114	8074.013.710				
EDF 35 SAE A 2-4 F D. 25 CH 8	360	17	114	8074.014.710				
EDF 45 SAE A 2-4 F D. 25 CH 8	470	23	114	8074.015.710				
EDF 55 SAE A 2-4 F D. 25 CH 8	600	27	114	8074.016.710				

EDF								
Icon	Cfs <sub>min</sub> [Nm]	Pa <sub>min</sub> [bar]	P	Kod / Code Bestell Nr. / Codice Code / Código	P <sub>max</sub> [bar]	OIL [lt]		Kg
						V1	B5	
EDF 10 SAE A 2-4 F D. 25.4 CH 6.35	110	13	114	İstenirse On request Auf Anfrage A richiesta Sur demande Bajo demanda	300	0.3	0.15	20
EDF 16 SAE A 2-4 F D. 25.4 CH 6.35	160	17	114					
EDF 20 SAE A 2-4 F D. 25.4 CH 6.35	220	23	114					
EDF 25 SAE A 2-4 F D. 25.4 CH 6.35	260	17	114					
EDF 35 SAE A 2-4 F D. 25.4 CH 6.35	360	17	114					
EDF 45 SAE A 2-4 F D. 25.4 CH 6.35	470	23	114					
EDF 55 SAE A 2-4 F D. 25.4 CH 6.35	600	27	114					

EDF								
Icon	Cfs <sub>min</sub> [Nm]	Pa <sub>min</sub> [bar]	P	Kod / Code Bestell Nr. / Codice Code / Código	P <sub>max</sub> [bar]	OIL [lt]		Kg
						V1	B5	
EDF 10 SAE A 2-4 F D. 31.75 CH 7.96	110	13	114	İstenirse On request Auf Anfrage A richiesta Sur demande Bajo demanda	300	0.3	0.15	20
EDF 16 SAE A 2-4 F D. 31.75 CH 7.96	160	17	114					
EDF 20 SAE A 2-4 F D. 31.75 CH 7.96	220	23	114					
EDF 25 SAE A 2-4 F D. 31.75 CH 7.96	260	17	114					
EDF 35 SAE A 2-4 F D. 31.75 CH 7.96	360	17	114					
EDF 45 SAE A 2-4 F D. 31.75 CH 7.96	470	23	114					
EDF 55 SAE A 2-4 F D. 31.75 CH 7.96	600	27	114					

EDF								
Icon	Cfs <sub>min</sub> [Nm]	Pa <sub>min</sub> [bar]	P	Kod / Code Bestell Nr. / Codice Code / Código	P <sub>max</sub> [bar]	OIL [lt]		Kg
						V1	B5	
EDF 10 SAE A 2-4 F D. 32 CH 10	110	13	114	8074.040.710	300	0.3	0.15	20
EDF 16 SAE A 2-4 F D. 32 CH 10	160	17	114	8074.041.710				
EDF 20 SAE A 2-4 F D. 32 CH 10	220	23	114	8074.042.710				
EDF 25 SAE A 2-4 F D. 32 CH 10	260	17	114	8074.043.710				
EDF 35 SAE A 2-4 F D. 32 CH 10	360	17	114	8074.044.710				
EDF 45 SAE A 2-4 F D. 32 CH 10	470	23	114	8074.045.710				
EDF 55 SAE A 2-4 F D. 32 CH 10	600	27	114	8074.046.710				

**TR** FRENLİ MOTOR ADAPTÖRÜ  
**IT** ENTRATE DIRETTE CON FRENO E ATTACCO MOTORE

**EN** DIRECT INPUT MOTOR ADAPTOR WITH BRAKE  
**FR** ENTRÉE DIRECTE AVEC FREIN POUR ADAPTATION MOTEUR

**DE** MOTORFLANSCH MIT INTEGRIERTER BREMSE  
**ES** ENTRADAS DIRECTAS CON FRENO PARA ACOPLAMIENTO MOTOR

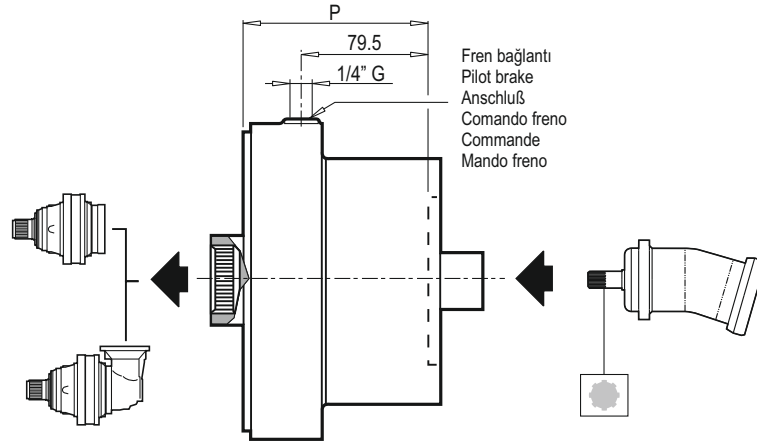

EF								
	Cfs <sub>min</sub> [Nm]	Pa <sub>min</sub> [bar]	P	Kod / Code Bestell Nr. / Codice Code / Código	P <sub>max</sub> [bar]	OIL [t]		Kg
						V1	B5	
EF 10 per/for GLC-OMSS-HPRC	110	13	118	2074.015.060	300	0.3	0.15	20
EF 16 per/for GLC-OMSS-HPRC	160	17	118	2074.015.061				
EF 20 per/for GLC-OMSS-HPRC	220	23	118	2074.015.062				
EF 25 per/for GLC-OMSS-HPRC	260	17	118	2074.015.063				
EF 35 per/for GLC-OMSS-HPRC	360	17	118	2074.015.064				
EF 45 per/for GLC-OMSS-HPRC	470	23	118	2074.015.065				
EF 55 per/for GLC-OMSS-HPRC	600	27	118	2074.015.066				

EF								
	Cfs <sub>min</sub> [Nm]	Pa <sub>min</sub> [bar]	P	Kod / Code Bestell Nr. / Codice Code / Código	P <sub>max</sub> [bar]	OIL [t]		Kg
						V1	B5	
EF 10 per/for EATON 2000 BEARINGLESS	110	13	118	İstenirse On request Auf Anfrage A richiesta Sur demande Bajo demanda	300	0.3	0.15	20
EF 16 per/for EATON 2000 BEARINGLESS	160	17	118					
EF 20 per/for EATON 2000 BEARINGLESS	220	23	118					
EF 25 per/for EATON 2000 BEARINGLESS	260	17	118					
EF 35 per/for EATON 2000 BEARINGLESS	360	17	118					
EF 45 per/for EATON 2000 BEARINGLESS	470	23	118					
EF 55 per/for EATON 2000 BEARINGLESS	600	27	118					

**TR** FRENLİ MOTOR ADAPTÖRÜ  
**IT** ENTRATE DIRETTE CON FRENO E ATTACCO MOTORE

**EN** DIRECT INPUT MOTOR ADAPTOR WITH BRAKE  
**FR** ENTRÉE DIRECTE AVEC FREIN POUR ADAPTATION MOTEUR

**DE** MOTORFLANSCH MIT INTEGRIERTER BREMSE  
**ES** ENTRADAS DIRECTAS CON FRENO PARA ACOPLAMIENTO MOTOR

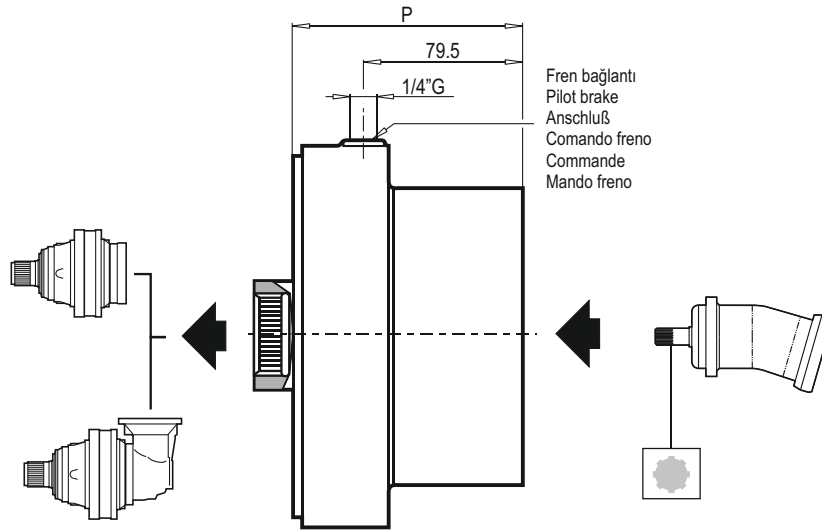

EF								
	Cfs <sub>min</sub> [Nm]	Pa <sub>min</sub> [bar]	P	Kod / Code Bestell Nr. / Codice Code / Código	P <sub>max</sub> [bar]	OIL [t]		Kg
						V1	B5	
EF 10 SAE A 2-4 F 16/32 DP 9TH	110	13	114	İstenirse On request Auf Anfrage A richiesta Sur demande Bajo demanda	300	0.3	0.15	20
EF 16 SAE A 2-4 F 16/32 DP 9TH	160	17	114					
EF 20 SAE A 2-4 F 16/32 DP 9TH	220	23	114					
EF 25 SAE A 2-4 F 16/32 DP 9TH	260	17	114					
EF 35 SAE A 2-4 F 16/32 DP 9TH	360	17	114					
EF 45 SAE A 2-4 F 16/32 DP 9TH	470	23	114					
EF 55 SAE A 2-4 F 16/32 DP 9TH	600	27	114					

EF								
	Cfs <sub>min</sub> [Nm]	Pa <sub>min</sub> [bar]	P	Kod / Code Bestell Nr. / Codice Code / Código	P <sub>max</sub> [bar]	OIL [t]		Kg
						V1	B5	
EF 10 SAE A 2-4 F 16/32 DP 13TH	110	13	114	İstenirse On request Auf Anfrage A richiesta Sur demande Bajo demanda	300	0.3	0.15	20
EF 16 SAE A 2-4 F 16/32 DP 13TH	160	17	114					
EF 20 SAE A 2-4 F 16/32 DP 13TH	220	23	114					
EF 25 SAE A 2-4 F 16/32 DP 13TH	260	17	114					
EF 35 SAE A 2-4 F 16/32 DP 13TH	360	17	114					
EF 45 SAE A 2-4 F 16/32 DP 13TH	470	23	114					
EF 55 SAE A 2-4 F 16/32 DP 13TH	600	27	114					

EF								
	Cfs <sub>min</sub> [Nm]	Pa <sub>min</sub> [bar]	P	Kod / Code Bestell Nr. / Codice Code / Código	P <sub>max</sub> [bar]	OIL [t]		Kg
						V1	B5	
EF 10 SAE A 2-4 F 12/24 DP 14TH	110	13	114	İstenirse On request Auf Anfrage A richiesta Sur demande Bajo demanda	300	0.3	0.15	20
EF 16 SAE A 2-4 F 12/24 DP 14TH	160	17	114					
EF 20 SAE A 2-4 F 12/24 DP 14TH	220	23	114					
EF 25 SAE A 2-4 F 12/24 DP 14TH	260	17	114					
EF 35 SAE A 2-4 F 12/24 DP 14TH	360	17	114					
EF 45 SAE A 2-4 F 12/24 DP 14TH	470	23	114					
EF 55 SAE A 2-4 F 12/24 DP 14TH	600	27	114					

EF								
	Cfs <sub>min</sub> [Nm]	Pa <sub>min</sub> [bar]	P	Kod / Code Bestell Nr. / Codice Code / Código	P <sub>max</sub> [bar]	OIL [t]		Kg
						V1	B5	
EF 10 SAE A 2-4 F 1" 6B	110	13	114	2074.015.040	300	0.3	0.15	20
EF 16 SAE A 2-4 F 1" 6B	160	17	114	2074.015.041				
EF 20 SAE A 2-4 F 1" 6B	220	23	114	2074.015.042				
EF 25 SAE A 2-4 F 1" 6B	260	17	114	2074.015.043				
EF 35 SAE A 2-4 F 1" 6B	360	17	114	2074.015.044				
EF 45 SAE A 2-4 F 1" 6B	470	23	114	2074.015.045				
EF 55 SAE A 2-4 F 1" 6B	600	27	114	2074.015.046				

**TR** FRENLİ MOTOR ADAPTÖRÜ  
**IT** ENTRATE DIRETTE CON FRENO E ATTACCO MOTORE

**EN** DIRECT INPUT MOTOR ADAPTOR WITH BRAKE  
**FR** ENTRÉE DIRECTE AVEC FREIN POUR ADAPTATION MOTEUR

**DE** MOTORFLANSCH MIT INTEGRIERTER BREMSE  
**ES** ENTRADAS DIRECTAS CON FRENO PARA ACOPLAMIENTO MOTOR

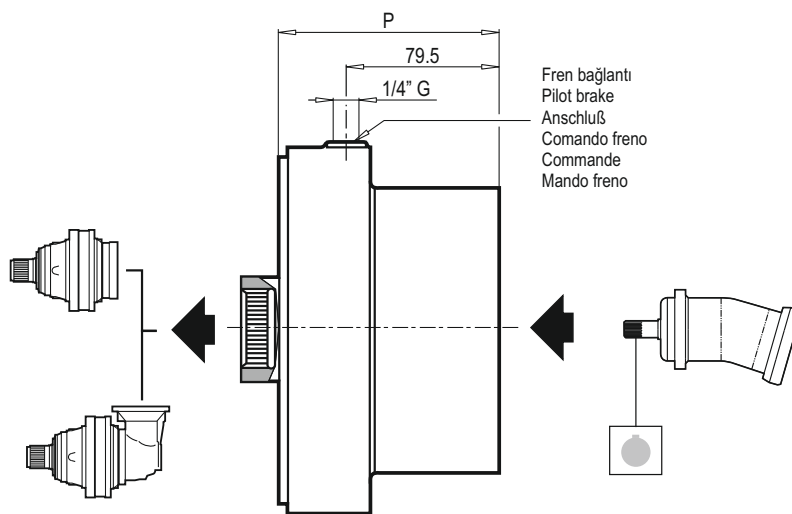

EF								
	Cfs <sub>min</sub> [Nm]	Pa <sub>min</sub> [bar]	P	Kod / Code Bestell Nr. / Codice Code / Código	P <sub>max</sub> [bar]	OIL [t]		Kg
						V1	B5	
EF 10 SAE A 2-4 F D. 25.4 CH 8	110	13	114	2074.014.010	300	0.3	0.15	20
EF 16 SAE A 2-4 F D. 25.4 CH 8	160	17	114	2074.014.011				
EF 20 SAE A 2-4 F D. 25.4 CH 8	220	23	114	2074.014.012				
EF 25 SAE A 2-4 F D. 25.4 CH 8	260	17	114	2074.014.013				
EF 35 SAE A 2-4 F D. 25.4 CH 8	360	17	114	2074.014.014				
EF 45 SAE A 2-4 F D. 25.4 CH 8	470	23	114	2074.014.015				
EF 55 SAE A 2-4 F D. 25.4 CH 8	600	27	114	2074.014.016				

EF								
	Cfs <sub>min</sub> [Nm]	Pa <sub>min</sub> [bar]	P	Kod / Code Bestell Nr. / Codice Code / Código	P <sub>max</sub> [bar]	OIL [t]		Kg
						V1	B5	
EF 10 SAE A 2-4 F D. 25.4 CH 6.35	110	13	114	İstenirse On request Auf Anfrage A richiesta Sur demande Bajo demanda	300	0.3	0.15	20
EF 16 SAE A 2-4 F D. 25.4 CH 6.35	160	17	114					
EF 20 SAE A 2-4 F D. 25.4 CH 6.35	220	23	114					
EF 25 SAE A 2-4 F D. 25.4 CH 6.35	260	17	114					
EF 35 SAE A 2-4 F D. 25.4 CH 6.35	360	17	114					
EF 45 SAE A 2-4 F D. 25.4 CH 6.35	470	23	114					
EF 55 SAE A 2-4 F D. 25.4 CH 6.35	600	27	114					

EF								
	Cfs <sub>min</sub> [Nm]	Pa <sub>min</sub> [bar]	P	Kod / Code Bestell Nr. / Codice Code / Código	P <sub>max</sub> [bar]	OIL [t]		Kg
						V1	B5	
EF 10 SAE A 2-4 F D. 31.75 CH 7.96	110	13	114	İstenirse On request Auf Anfrage A richiesta Sur demande Bajo demanda	300	0.3	0.15	20
EF 16 SAE A 2-4 F D. 31.75 CH 7.96	160	17	114					
EF 20 SAE A 2-4 F D. 31.75 CH 7.96	220	23	114					
EF 25 SAE A 2-4 F D. 31.75 CH 7.96	260	17	114					
EF 35 SAE A 2-4 F D. 31.75 CH 7.96	360	17	114					
EF 45 SAE A 2-4 F D. 31.75 CH 7.96	470	23	114					
EF 55 SAE A 2-4 F D. 31.75 CH 7.96	600	27	114					

EF								
	Cfs <sub>min</sub> [Nm]	Pa <sub>min</sub> [bar]	P	Kod / Code Bestell Nr. / Codice Code / Código	P <sub>max</sub> [bar]	OIL [t]		Kg
						V1	B5	
EF 10 SAE A 2-4 F D. 32 CH 10	110	13	114	2074.014.040	300	0.3	0.15	20
EF 16 SAE A 2-4 F D. 32 CH 10	160	17	114	2074.014.041				
EF 20 SAE A 2-4 F D. 32 CH 10	220	23	114	2074.014.042				
EF 25 SAE A 2-4 F D. 32 CH 10	260	17	114	2074.014.043				
EF 35 SAE A 2-4 F D. 32 CH 10	360	17	114	2074.014.044				
EF 45 SAE A 2-4 F D. 32 CH 10	470	23	114	2074.014.045				
EF 55 SAE A 2-4 F D. 32 CH 10	600	27	114	2074.014.046				