

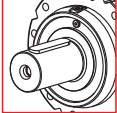

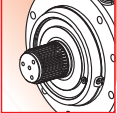



TEKNİK VERİLER / TECHNICAL DATA / TECHNISCHE DATEN / DATI TECNICI / DONNÉES TECHNIQUES / DATOS TÉCNICAS

	i_{ges}	M_{2max} (n1: 1400rpm) (Nm)	OUTPUT		INPUT	
5001	3.78 ... 7.25	2140				
			Ø65	58X53 DIN 5482	Ø28 - Ø42 Ø65 - Ø1"3/8	Hydraulic Motor
5002	13.4 ... 48.9	2790				
			Ø75	58X53 DIN 5482	Electric Motor	Worm gearboxes
5003	52.1 ... 330.3	3750				
5004	352.0 ... 1845.3	5310				Brake

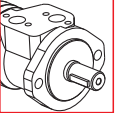
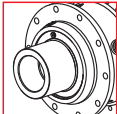
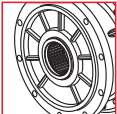
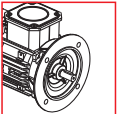
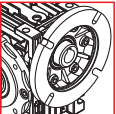
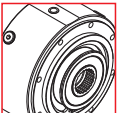
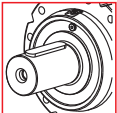
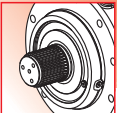
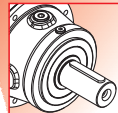
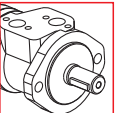
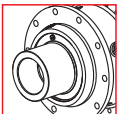
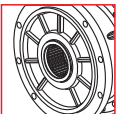
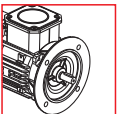
	i_{ges}	M_{2max} (n1: 1400rpm) (Nm)	OUTPUT		INPUT	
5002	13.1 ÷ 39.5	2890				
			Ø65	58X53 DIN 5482	Ø28 - Ø42 Ø65 - Ø1"3/8	Hydraulic Motor
5003	39.4 ÷ 143.5	3360				
			Ø75	58X53 DIN 5482	Electric Motor	
5004	140.1 ÷ 1244.1	4580				Brake

	Pt [kW]	n _{1max} [min ⁻¹]	i _{ges}	Mc [kNm]				Giriş- Input - Antrieb - Entrada - Entrée - Entrada			
				n ₂ x h	n ₂ x h	n ₂ x h	n ₂ x h				
				10.000	20.000	50.000	100.000	IEC (B5)	PMRV / PRV	EL - EML EM - EP - ET	
PL 5001	20	2800	3.78	5.89	5.21	4.44	3.93	63 71 80 90	100 112 132 160	050 063 075 090 110 130	EL C 28 EL C 42 EML 42 EML 1"3/8 Z6 EM 65 EM 1"3/8 Z6 EP 65
			4.13	5.37	4.75	4.05	3.58				
			5.17	4.39	3.89	3.30	2.93				
			6.00	3.85	3.41	2.90	2.57				
			7.25	3.01	2.66	2.26	2.01				
PL 5002	15	2800	13.4	5.89	5.21	4.44	3.93	63 71 80 90 100 112 132 160	050 063 075 090	EL C 28 EL C 42 EML 42 EML 1"3/8 Z6	
			16.2	5.89	5.21	4.44	3.93				
			18.4	4.39	3.89	3.30	2.93				
			23.1	5.37	4.75	4.05	3.58				
			28.9	4.39	3.89	3.30	2.93				
			34.9	4.39	3.89	3.30	2.93				
			40.5	3.85	3.41	2.90	2.57				
			48.9	3.01	2.66	2.26	2.01				
PL 5003	10	2800	52.1	5.37	4.75	4.05	3.58	63 71 80 90 100 112 132 160	050 063 075 090	EL C 28 EL C 42 EML 42 EML 1"3/8 Z6	
			57.6	5.89	5.21	4.44	3.93				
			62.9	5.37	4.75	4.05	3.58				
			75.2	5.89	5.21	4.44	3.93				
			82.1	5.37	4.75	4.05	3.58				
			90.7	5.89	5.21	4.44	3.93				
			99.0	5.37	4.75	4.05	3.58				
			119.3	5.37	4.75	4.05	3.58				
			129.4	5.37	4.75	4.05	3.58				
			149.5	4.39	3.89	3.30	2.93				
			155.9	5.37	4.75	4.05	3.58				
			162.0	4.39	3.89	3.30	2.93				
			173.6	3.85	3.41	2.90	2.57				
			195.3	4.39	3.89	3.30	2.93				
			235.4	4.39	3.89	3.30	2.93				
			273.4	3.85	3.41	2.90	2.57				
302.2	4.39	3.89	3.30	2.93							
330.3	3.01	2.66	2.26	2.01							
PL 5004	6	2800	352.0	5.37	4.75	4.05	3.58	63 71 80 90 100 112 132	050 063 075 090	EL C 28 EL C 42 EML 42 EML 1"3/8 Z6	
			365.8	4.39	3.89	3.30	2.93				
			388.6	5.89	5.21	4.44	3.93				
			413.9	5.89	5.21	4.44	3.93				
			424.3	5.37	4.75	4.05	3.58				
			468.4	5.89	5.21	4.44	3.93				
			511.4	5.37	4.75	4.05	3.58				
			554.4	5.37	4.75	4.05	3.58				
			612.0	5.89	5.21	4.44	3.93				
			668.2	5.37	4.75	4.05	3.58				
			737.7	5.89	5.21	4.44	3.93				
			805.5	5.37	4.75	4.05	3.58				
			858.0	5.37	4.75	4.05	3.58				
			907.3	4.39	3.89	3.30	2.93				
			1052.5	5.37	4.75	4.05	3.58				
			1121.1	5.37	4.75	4.05	3.58				
			1318.3	4.39	3.89	3.30	2.93				
1589.0	4.39	3.89	3.30	2.93							
1845.3	3.85	3.41	2.90	2.57							

	Pt [kW]	n _{1max} [min ⁻¹]	i _{ges}	Mc [kNm]				Giriş- Input - Antrieb - Entrada - Entrée - Entrada	
				n ₂ x h	n ₂ x h	n ₂ x h	n ₂ x h		
				10.000	20.000	50.000	100.000	IEC (B5)	EL - EML EM - EP - ET
PLB 5002	15	2800	13.1	5.89	5.21	4.44	3.93	80 90 100 112 132 160	EL C 28 EL C 42 EML 42 EML 1"3/8 Z6 EM 65 EM 1"3/8 Z6 EP 65
			14.2	5.37	4.75	4.05	3.58		
			17.8	4.39	3.89	3.30	2.93		
			20.6	5.89	5.21	4.44	3.93		
			22.5	5.37	4.75	4.05	3.58		
			28.1	4.39	3.89	3.30	2.93		
			32.7	3.85	3.41	2.90	2.57		
			39.5	3.01	2.66	2.26	2.01		
PLB 5003	10	2800	39.4	5.89	5.21	4.44	3.93	80 90 100 112 132	EL C 28 EL C 42 EML 42 EML 1"3/8 Z6 EM 65 EM 1"3/8 Z6 EP 65
			47.5	5.89	5.21	4.44	3.93		
			53.9	4.39	3.89	3.30	2.93		
			67.8	5.37	4.75	4.05	3.58		
			75.4	3.85	3.41	2.90	2.57		
			84.9	4.39	3.89	3.30	2.93		
			91.1	3.01	2.66	2.26	2.01		
			102.3	4.39	3.89	3.30	2.93		
			118.8	3.85	3.41	2.90	2.57		
			143.5	3.01	2.66	2.26	2.01		
			PLB 5004	6	2800	140.1	5.89		
168.9	5.89	5.21				4.44	3.93		
184.4	5.37	4.75				4.05	3.58		
220.6	5.89	5.21				4.44	3.93		
240.9	5.37	4.75				4.05	3.58		
265.9	5.89	5.21				4.44	3.93		
290.4	5.37	4.75				4.05	3.58		
320.6	5.89	5.21				4.44	3.93		
350.0	5.37	4.75				4.05	3.58		
422.4	3.85	3.41				2.90	2.57		
449.4	5.37	4.75				4.05	3.58		
475.3	4.39	3.89				3.30	2.93		
509.1	3.85	3.41				2.90	2.57		
551.9	3.85	3.41				2.90	2.57		
615.2	3.01	2.66				2.26	2.01		
665.3	3.85	3.41				2.90	2.57		
735.5	4.39	3.89				3.30	2.93		
801.9	3.85	3.41				2.90	2.57		
1244.1	3.01	2.66	2.26	2.01					



$$M_{\max} = M_C \times 2$$

(n₂ x h = 20.000)

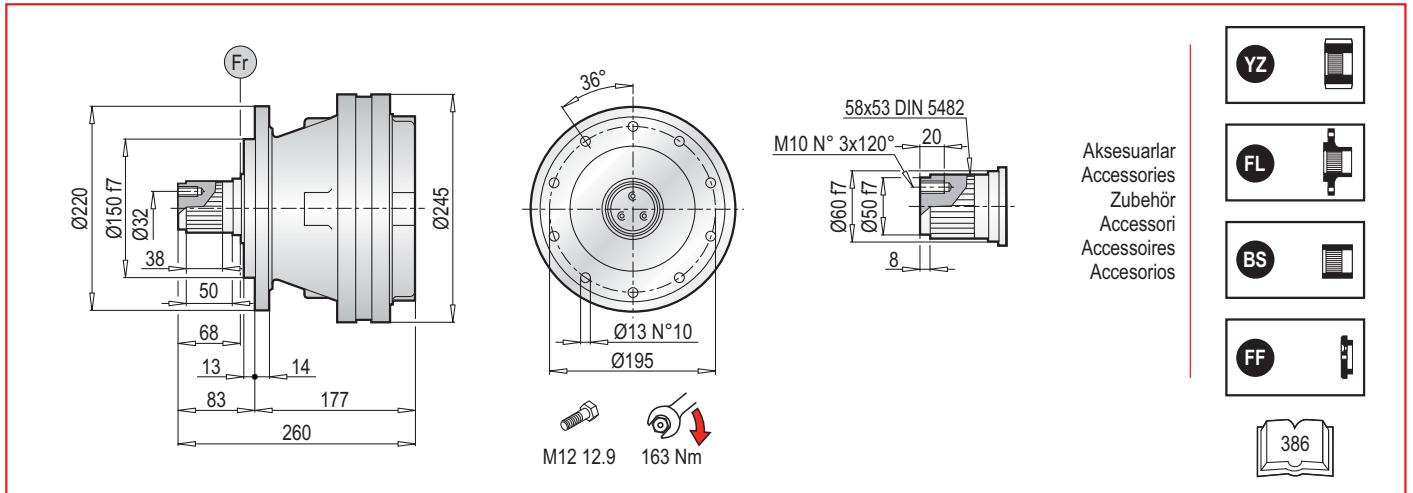

PL 5000 MS - Elektrik Motor Adaptörleri (IEC) / Electric Motor Couplings (IEC) / Anbauvorrichtung Für Elektromotore (IEC) / Predisposizioni Per Motori Elettrici (IEC) / Adaptations Pour Moteurs Electriques (IEC) / Acoplamientos Para Motores Eléctricos (IEC)

PL	IEC 63			IEC 71			IEC 80			IEC 90			IEC 100		
	L _T	Z	ØD	L _T	Z	ØD	L _T	Z	ØD	L _T	Z	ØD	L _T	Z	ØD
5001	213			213			233			233			243		
5002	274	36	140	274	36	160	294	56	200	294	56	200	304	66	250
5003	322			322			342			342			352		
5004	370			370			390			390			400		

PL	IEC 112			IEC 132			IEC 160			IEC 180				
	L _T	Z	ØD	L _T	Z	ØD	L _T	Z	ØD	L _T	Z	ØD		
5001	243			277			316			316	139	350		
5002	304	66	250	338	100	300	377	139	350	-				
5003	352			386			425			-				
5004	400			434			-			-				

PL	IEC ~ Kg								
	63	71	80	90	100	112	132	160	180
5001	39	39	41	41	42	42	46	56	56
5002	47	47	49	49	50	50	54	64	-
5003	53	53	55	55	56	56	60	70	-
5004	59	59	61	61	62	62	-	-	-

PL 5000 MS - Giriş Milleri / Input Shafts / Antriebswellen / Alberi Entrada / Arbres D'entree / Ejes De Entrada

PL	EL C 28				EL C 42				EML 42				EML 1"3/8 Z6				EM 65				EM 1"3/8 Z6			
	L _T	Z	L	Ød	L _T	Z	L	Ød	L _T	Z	L	Ød	L _T	Z	L	Ød	L _T	Z	L	Ød	L _T	Z	L	Ød
5001	241				241				271				271				312	121.5	105	65	312	121.5	105	1"3/8
5002	302	64	50	28	302	64	82	42	332	94	82	42	332	94	106	1"3/8	-							
5003	350				350				380				380				-							
5004	398				398				428				428				-							

PL	EP 65				PL	~ Kg						
	L _T	Z	L	Ød		EL C 28	EL C 42	EML 42	EML 1"3/8 Z6	EM 65	EM 1"3/8 Z6	EP 65
5001	343.5	153	105	65	5001	39.5	40.0	43.0	43.0	51.0	51.0	60.0
5002	-	-	-	-	5002	47.5	48.0	51.0	51.0	-	-	-
5003	-	-	-	-	5003	53.5	54.0	57.0	57.0	-	-	-
5004	-	-	-	-	5004	59.5	60.0	63.0	63.0	-	-	-

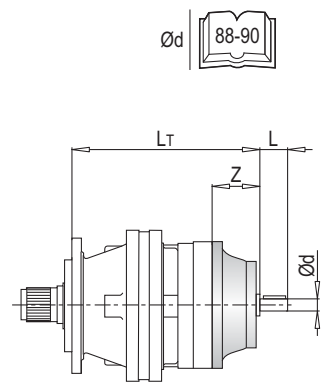
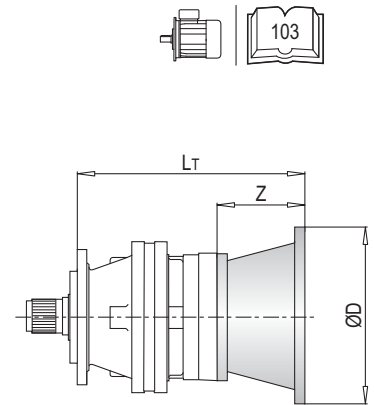

PL 5000 MS - Sonsuz Dişli Redüktör Adaptörleri (PMRV/PRV) / Worm Gearbox Adaptors (PMRV/PRV) / Anschluss Für Schneckengetriebe (PMRV/PRV) / Predisposizioni Per Riduttori A Vite Senza Fine (PMRV/PRV) / Adaptation Pour Reducteurs A Vis Sans Fin (PMRV/PRV) / Acoplamiento Para Reductores De Tornillo Sin Fin (PMRV/PRV)

PL	PMRV/PRV 050					PMRV/PRV 063					PMRV/PRV 075				
	LM	l	h	MA	G	LM	l	h	MA	G	LM	l	h	MA	G
5001	302.5					312					291				
5002	363.5	50	110	60	80	473	63	135	72	95	352	75	161	86	112.5
5003	421					400									
5004	459.5					469					448				

PL	PMRV/PRV 090					PMRV/PRV 110					PMRV/PRV 130				
	LM	l	h	MA	G	LM	l	h	MA	G	LM	l	h	MA	G
5001	301					328.5	110	237.5	127.5	160	336	130	277.5	147.5	180
5002	362	90	193	103	129.5	-					-				
5003	410					-					-				
5004	458					-					-				

PL	PMRV/PRV ~ Kg					
	050	063	075	090	110	130
5001	42	45.5	48	53	80	97
5002	50	53.5	56	61	-	-
5003	56	59.5	62	67	-	-
5004	62	65.5	68	73	-	-

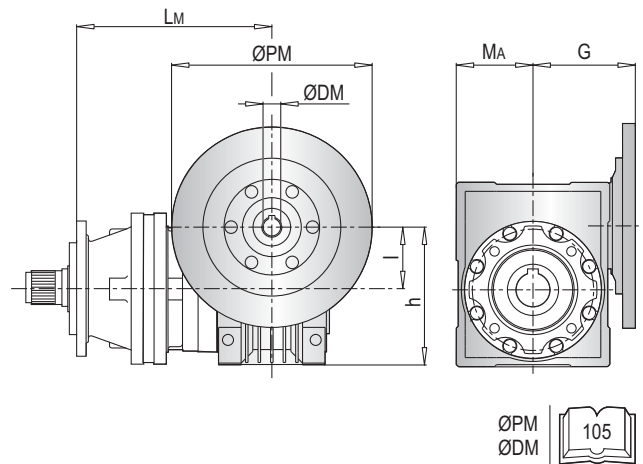

PLB 5000 MS - Elektrik Motor Adaptörleri (IEC) / Electric Motor Couplings (IEC) / Anbauvorrichtung Für Elektromotore (IEC) / Predisposizioni Per Motori Elettrici (IEC) / Adaptations Pour Moteurs Electriques (IEC) / Acoplamientos Para Motores Eléctricos (IEC)

PLB	IEC 80				IEC 90				IEC 100				IEC 112			
	A	L _T	Z	ØD	A	L _T	Z	ØD	A	L _T	Z	ØD	A	L _T	Z	ØD
5002	278.5	296			278.5	296			278.5	306			278.5	306		
5003	313	216	56	200	313	216	56	200	313	226	66	250	313	226	66	250
5004	361				361				361				361			

PLB	IEC 132				IEC 160			
	A	L _T	Z	ØD	A	L _T	Z	ØD
5002	278.5	340			278.5	379	139	350
5003	313	260	100	300	-			
5004	361				-			

PLB	IEC ~ Kg					
	80	90	100	112	132	160
5002	59	59	60	60	64	74
5003	67	67	68	68	72	-
5004	73	73	74	74	78	-

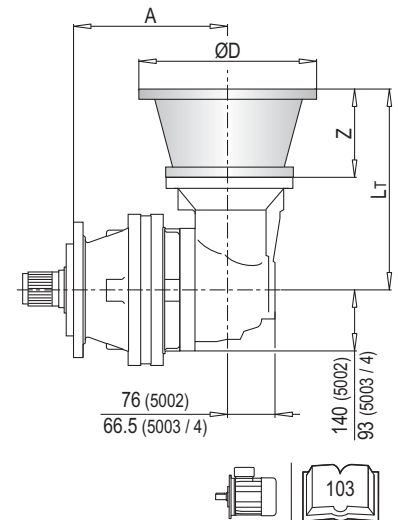

PLB 5000 MS - Giriş Milleri / Input Shafts / Antriebswellen / Alberi Entrata / Arbres D'entree / Ejes De Entrada

PLB	EL C 28					EL C 42					EML 42					EML 1"3/8 Z6					EM 65					
	A	L _T	Z	L	Ød	A	L _T	Z	L	Ød	A	L _T	Z	L	Ød	A	L _T	Z	L	Ød	A	L _T	Z	L	Ød	
5002	278.5	304				278.5	304				278.5	334				278.5	334				278.5	377.5				
5003	313	224	64	50	28	313	224	64	82	42	313	254	94	82	42	313	254	94	106	1"3/8	313	297.5	121.5	105	65	
5004	361					361					361					361										

PLB	EM 1"3/8 Z6					EP 65				
	A	L _T	Z	L	Ød	A	L _T	Z	L	Ød
5002	278.5	377.5				278.5	409			
5003	313	297.5	121.5	105	1"3/8	313	329	153	105	65
5004	361					361				

PLB	~ Kg							
	EL C 28	EL C 42	EML 42	EML 1"3/8 Z6	EM 65	EM 1"3/8 Z6	EP 65	
5002	57.5	58.0	67.0	67.0	75.0	75.0	84.0	
5003	65.5	66.0	75.0	75.0	83.0	83.0	92.0	
5004	71.5	72.0	81.0	81.0	89.0	89.0	98.0	

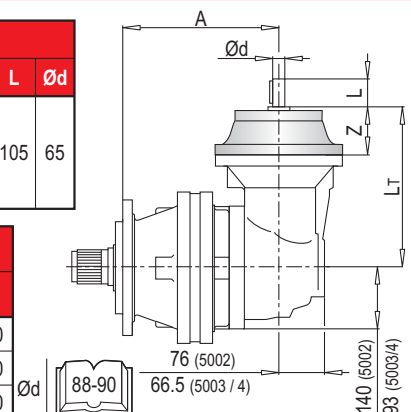

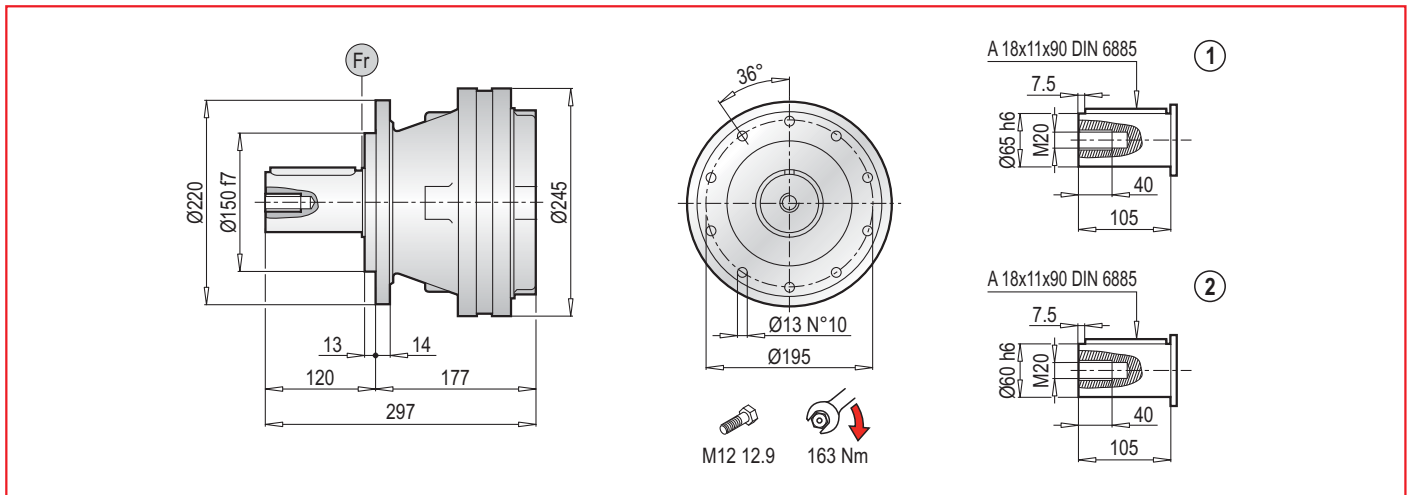

PL 5000 MC - Elektrik Motor Adaptörleri (IEC) / Electric Motor Couplings (IEC) / Anbauvorrichtung Für Elektromotore (IEC) / Predisposizioni Per Motori Elettrici (IEC) / Adaptations Pour Moteurs Electriques (IEC) / Acoplamientos Para Motores Eléctricos (IEC)

PL	IEC 63			IEC 71			IEC 80			IEC 90			IEC 100		
	L _T	Z	ØD	L _T	Z	ØD	L _T	Z	ØD	L _T	Z	ØD	L _T	Z	ØD
5001	213	36	140	213	36	160	233	56	200	233	56	200	243	66	250
5002	274			274			294			294			304		
5003	322			322			342			342			352		
5004	370			370			390			390			400		

PL	IEC 112			IEC 132			IEC 160			IEC 180		
	L _T	Z	ØD	L _T	Z	ØD	L _T	Z	ØD	L _T	Z	ØD
5001	243	66	250	277	100	300	316	139	350	316	139	350
5002	304			338			377			-		
5003	352			386			425			-		
5004	400			434			-			-		

PL	IEC ~ Kg								
	63	71	80	90	100	112	132	160	180
5001	39	39	41	41	42	42	46	56	56
5002	47	47	49	49	50	50	54	64	-
5003	53	53	55	55	56	56	60	70	-
5004	59	59	61	61	62	62	-	-	-

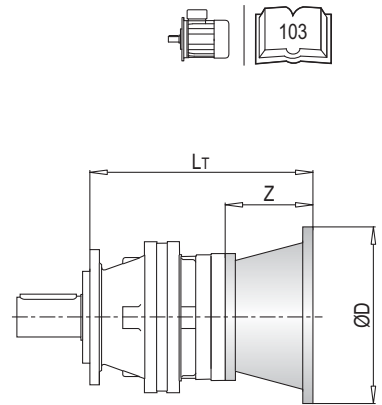

PL 5000 MC - Giriş Milleri / Input Shafts / Antriebswellen / Alberi Entrada / Arbres D'entree / Ejes De Entrada

PL	EL C 28				EL C 42				EML 42				EML 1"3/8 Z6				EM 65				EM 1"3/8 Z6			
	L _T	Z	L	Ød	L _T	Z	L	Ød	L _T	Z	L	Ød	L _T	Z	L	Ød	L _T	Z	L	Ød	L _T	Z	L	Ød
5001	241	64	50	28	241	64	82	42	271	94	82	42	271	94	106	1"3/8	312	121.5	105	65	312	121.5	105	1"3/8
5002	302				302				332				332				-							
5003	350				350				380				380				-							
5004	398				398				428				428				-							

PL	EP 65				PL	~ Kg						
	L _T	Z	L	Ød		EL C 28	EL C 42	EML 42	EML 1"3/8 Z6	EM 65	EM 1"3/8 Z6	EP 65
5001	343.5	153	105	65	5001	39.5	40.0	43.0	43.0	51.0	51.0	60.0
5002	-	-	-	-	5002	47.5	48.0	51.0	51.0	-	-	-
5003	-	-	-	-	5003	53.5	54.0	57.0	57.0	-	-	-
5004	-	-	-	-	5004	59.5	60.0	63.0	63.0	-	-	-

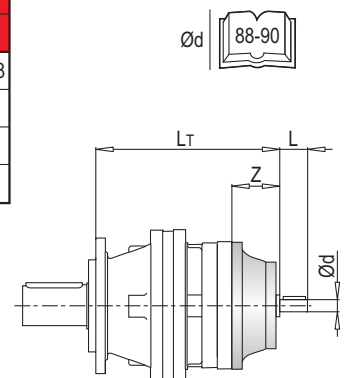

PL 5000 MC - Sonsuz Dişli Redüktör Adaptörleri (PMRV/PRV) / Worm Gearbox Adaptors (PMRV/PRV) / Anschluss Für Schneckengetriebe (PMRV/PRV) / Predisposizioni Per Riduttori A Vite Senza Fine (PMRV/PRV) / Adaptation Pour Reducteurs A Vis Sans Fin (PMRV/PRV) / Acoplamiento Para Reductores De Tornillo Sin Fin (PMRV/PRV)

PL	PMRV/PRV 050					PMRV/PRV 063					PMRV/PRV 075				
	L _M	l	h	MA	G	L _M	l	h	MA	G	L _M	l	h	MA	G
5001	302.5	50	110	60	80	312	63	135	72	95	291	75	161	86	112.5
5002	363.5					473					352				
5003	411.5					421					400				
5004	459.5					469					448				

PL	PMRV/PRV 090					PMRV/PRV 110					PMRV/PRV 130				
	L _M	l	h	MA	G	L _M	l	h	MA	G	L _M	l	h	MA	G
5001	301	90	193	103	129.5	328.5	110	237.5	127.5	160	336	130	277.5	147.5	180
5002	362					-	-	-	-						
5003	410					-	-	-	-						
5004	458					-	-	-	-						

PL	PMRV/PRV ~ Kg					
	050	063	075	090	110	130
5001	42	45.5	48	53	80	97
5002	50	53.5	56	61	-	-
5003	56	59.5	62	67	-	-
5004	62	65.5	68	73	-	-

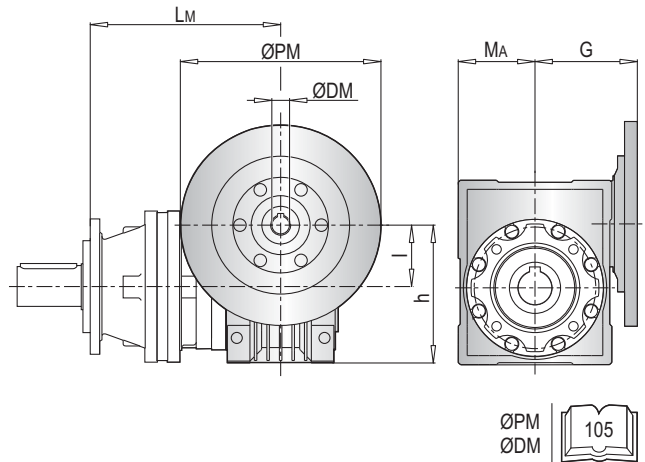

PLB 5000 MC - Elektrik Motor Kaplinleri (IEC) / Electric Motor Couplings (IEC) / Anbauvorrichtung Für Elektromotore (IEC) / Predisposizioni Per Motori Elettrici (IEC) / Adaptations Pour Moteurs Electriques (IEC) / Acoplamientos Para Motores Eléctricos (IEC)

PLB	IEC 80				IEC 90				IEC 100				IEC 112			
	A	L _T	Z	ØD	A	L _T	Z	ØD	A	L _T	Z	ØD	A	L _T	Z	ØD
5002	278.5	296	56	200	278.5	296	56	200	278.5	306	66	250	278.5	306	66	250
5003	313	216			313	216			313	226			313	226		
5004	361	361			361	361										

PLB	IEC 132				IEC 160			
	A	L _T	Z	ØD	A	L _T	Z	ØD
5002	278.5	340	100	300	278.5	379	139	350
5003	313	260			-	-		
5004	361	-			-	-		

PLB	IEC ~ Kg					
	80	90	100	112	132	160
5002	59	59	60	60	64	74
5003	67	67	68	68	72	-
5004	73	73	74	74	78	-

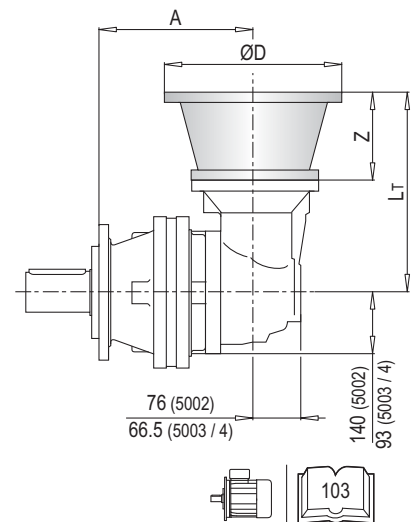

PLB 5000 MC - Giriş Milleri / Input Shafts / Antriebswellen / Alberi Entrata / Arbres D'entree / Ejes De Entrada

PLB	EL C 28					EL C 42					EML 42					EML 1"3/8 Z6					EM 65				
	A	L _T	Z	L	Ød	A	L _T	Z	L	Ød	A	L _T	Z	L	Ød	A	L _T	Z	L	Ød	A	L _T	Z	L	Ød
5002	278.5	304	64	50	28	278.5	304	64	82	42	278.5	334	94	82	42	278.5	334	94	106	1"3/8	278.5	377.5	121.5	105	65
5003	313	224				313	224				313	254				313	254				313	297.5			
5004	361	361				361	361																		

PLB	EM 1"3/8 Z6					EP 65						
	A	L _T	Z	L	Ød	A	L _T	Z	L	Ød		
5002	278.5	377.5	121.5	105	1"3/8	278.5	409	313	329	153	105	65
5003	313	297.5				313						
5004	361	361										

PLB	~ Kg							
	EL C 28	EL C 42	EML 42	EML 1"3/8 Z6	EM 65	EM 1"3/8 Z6	EP 65	
5002	57.5	58.0	67.0	67.0	75.0	75.0	84.0	
5003	65.5	66.0	75.0	75.0	83.0	83.0	92.0	
5004	71.5	72.0	81.0	81.0	89.0	89.0	98.0	

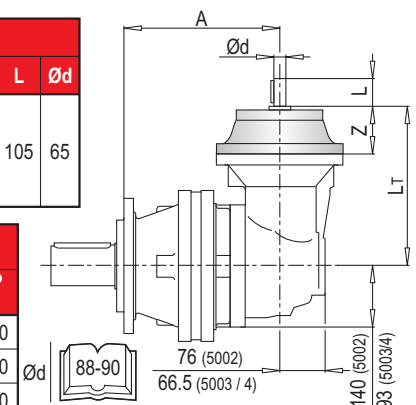

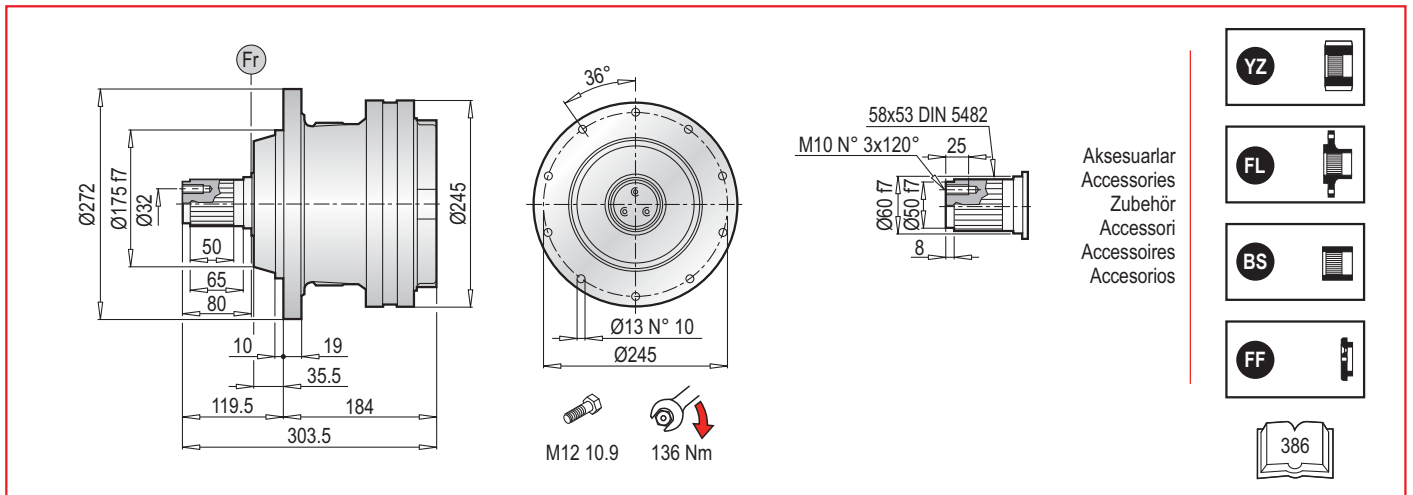

PL 5000 PS - Elektrik Motor Adaptörleri (IEC) / Electric Motor Couplings (IEC) / Anbauvorrichtung Für Elektromotore (IEC) / Predisposizioni Per Motori Elettrici (IEC) / Adaptations Pour Moteurs Electriques (IEC) / Acoplamientos Para Motores Eléctricos (IEC)

PL	IEC 63			IEC 71			IEC 80			IEC 90			IEC 100		
	L _T	Z	ØD	L _T	Z	ØD	L _T	Z	ØD	L _T	Z	ØD	L _T	Z	ØD
5001	220			220			240			240			250		
5002	281	36	140	281	36	160	301	56	200	301	56	200	311	66	250
5003	329			329			349			349			359		
5004	377			377			397			397			407		

PL	IEC 112			IEC 132			IEC 160			IEC 180				
	L _T	Z	ØD	L _T	Z	ØD	L _T	Z	ØD	L _T	Z	ØD		
5001	250			284			323			323	139	350		
5002	311	66	250	345	100	300	384	139	350	-				
5003	359			393			432			-				
5004	407			441			-			-				

PL	IEC ~ Kg								
	63	71	80	90	100	112	132	160	180
5001	48	48	50	50	51	51	55	65	56
5002	56	56	58	58	59	59	63	73	-
5003	62	62	64	64	65	65	69	79	-
5004	68	68	70	70	71	71	-	-	-

PL 5000 PS - Giriş Milleri / Input Shafts / Antriebswellen / Alberi Entrata / Arbres D'entree / Ejes De Entrada

PL	EL C 28				EL C 42				EML 42				EML 1"3/8 Z6				EM 65				EM 1"3/8 Z6			
	L _T	Z	L	Ød	L _T	Z	L	Ød	L _T	Z	L	Ød	L _T	Z	L	Ød	L _T	Z	L	Ød	L _T	Z	L	Ød
5001	248				248				278				278				319	121.5	105	65	319	121.5	105	1"3/8
5002	309	64	50	28	309	64	82	42	339	94	82	42	339	94	106	1"3/8	-				-			
5003	357				357				387				387				-							
5004	405				405				435				435				-				-			

PL	EP 65				PL	~ Kg						
	L _T	Z	L	Ød		EL C 28	EL C 42	EML 42	EML 1"3/8 Z6	EM 65	EM 1"3/8 Z6	EP 65
5001	350.5	153	105	65	5001	48.5	49.0	52.0	52.0	60.0	60.0	69.0
5002	-	-	-	-	5002	56.5	57.0	60.0	60.0	-	-	-
5003	-	-	-	-	5003	62.5	63.0	66.0	66.0	-	-	-
5004	-	-	-	-	5004	68.5	69.0	72.0	72.0	-	-	-

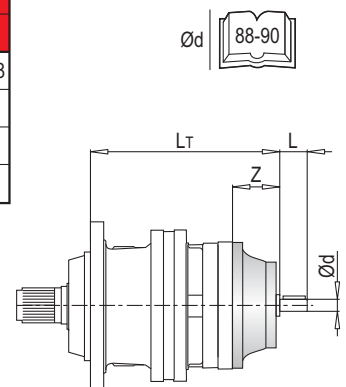
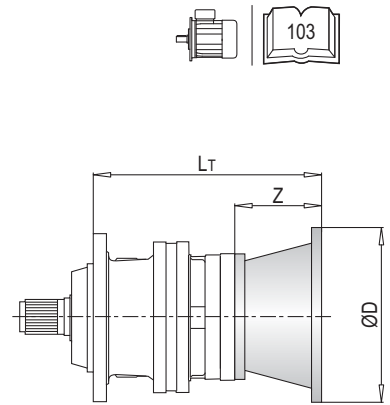

PL 5000 PS - Sonsuz Dişli Redüktör Adaptörleri (PMRV/PRV) / Worm Gearbox Adaptors (PMRV/PRV) / Anschluss Für Schneckengetriebe (PMRV/PRV) / Predisposizioni Per Riduttori A Vite Senza Fine (PMRV/PRV) / Adaptation Pour Reducteurs A Vis Sans Fin (PMRV/PRV) / Acoplamiento Para Reductores De Tornillo Sin Fin (PMRV/PRV)

PL	PMRV/PRV 050					PMRV/PRV 063					PMRV/PRV 075				
	LM	I	h	MA	G	LM	I	h	MA	G	LM	I	h	MA	G
5001	309.5					319					298				
5002	370.5	50	110	60	80	380	63	135	72	95	359	75	161	86	112.5
5003	418.5					428					407				
5004	466.5					476					455				

PL	PMRV/PRV 090					PMRV/PRV 110					PMRV/PRV 130				
	LM	I	h	MA	G	LM	I	h	MA	G	LM	I	h	MA	G
5001	308					335.5	110	237.5	127.5	160	343	130	277.5	147.5	180
5002	369	90	193	103	129.5	-					-				
5003	417					-					-				
5004	465					-					-				

PL	PMRV/PRV ~ Kg					
	050	063	075	090	110	130
5001	51	54.5	57	62	89	106
5002	59	62.5	65	70	-	-
5003	65	68.5	71	76	-	-
5004	71	74.5	77	82	-	-

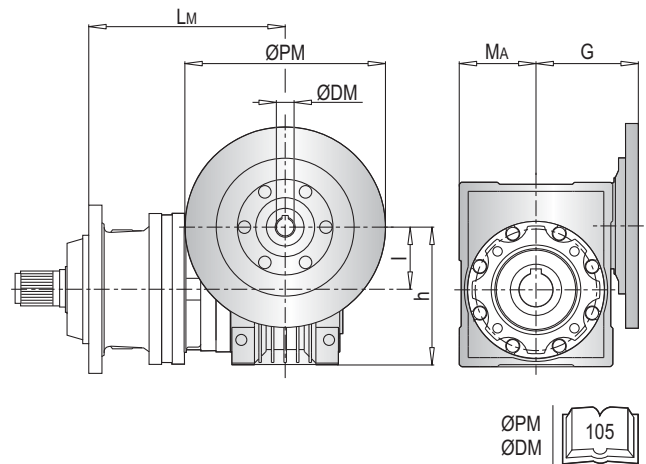

PLB 5000 PS - Elektrik Motor Adaptörleri (IEC) / Electric Motor Couplings (IEC) / Anbauvorrichtung Für Elektromotore (IEC) / Predisposizioni Per Motori Elettrici (IEC) / Adaptations Pour Moteurs Electriques (IEC) / Acoplamientos Para Motores Eléctricos (IEC)

PLB	IEC 80				IEC 90				IEC 100				IEC 112			
	A	L _T	Z	ØD	A	L _T	Z	ØD	A	L _T	Z	ØD	A	L _T	Z	ØD
5002	285.5	296			285.5	296			285.5	306			285.5	306		
5003	320	216	56	200	320	216	56	200	320	226	66	250	320	226	66	250
5004	368				368				368				368			

PLB	IEC 132				IEC 160			
	A	L _T	Z	ØD	A	L _T	Z	ØD
5002	285.5	340			285.5	379	139	350
5003	320	260	100	300	-			
5004	368				-			

PLB	IEC ~ Kg					
	80	90	100	112	132	160
5002	68	68	69	69	73	83
5003	76	76	77	77	81	-
5004	82	82	83	83	87	-

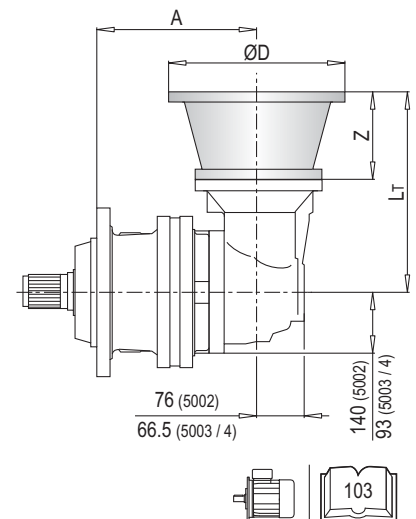

PLB 5000 PS - Giriş Milleri / Input Shafts / Antriebswellen / Alberi Entrata / Arbres D'entree / Ejes De Entrada

PLB	EL C 28					EL C 42					EML 42					EML 1"3/8 Z6					EM 65					
	A	L _T	Z	L	Ød	A	L _T	Z	L	Ød	A	L _T	Z	L	Ød	A	L _T	Z	L	Ød	A	L _T	Z	L	Ød	
5002	285.5	304				285.5	304				285.5	334				285.5	334				285.5	377.5				
5003	320	224	64	50	28	320	224	64	82	42	320	254	94	82	42	320	254	94	106	1"3/8	320	297.5	121.5	105	65	
5004	368					368					368					368										

PLB	EM 1"3/8 Z6					EP 65				
	A	L _T	Z	L	Ød	A	L _T	Z	L	Ød
5002	285.5	377.5				285.5	409			
5003	320	297.5	121.5	105	1"3/8	320	329	153	105	65
5004	368					368				

PLB	~ Kg						
	EL C 28	EL C 42	EML 42	EML 1"3/8 Z6	EM 65	EM 1"3/8 Z6	EP 65
5002	66.5	67.0	70.0	70.0	78.0	78.0	87.0
5003	74.5	75.0	78.0	78.0	86.0	86.0	95.0
5004	80.5	81.0	84.0	84.0	92.0	92.0	101.0

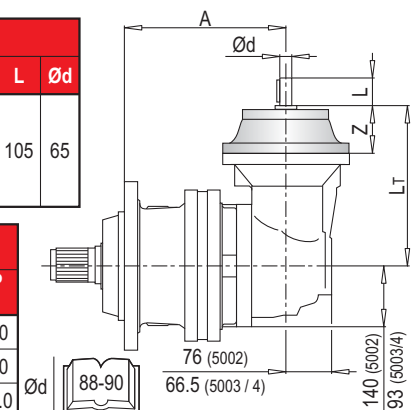

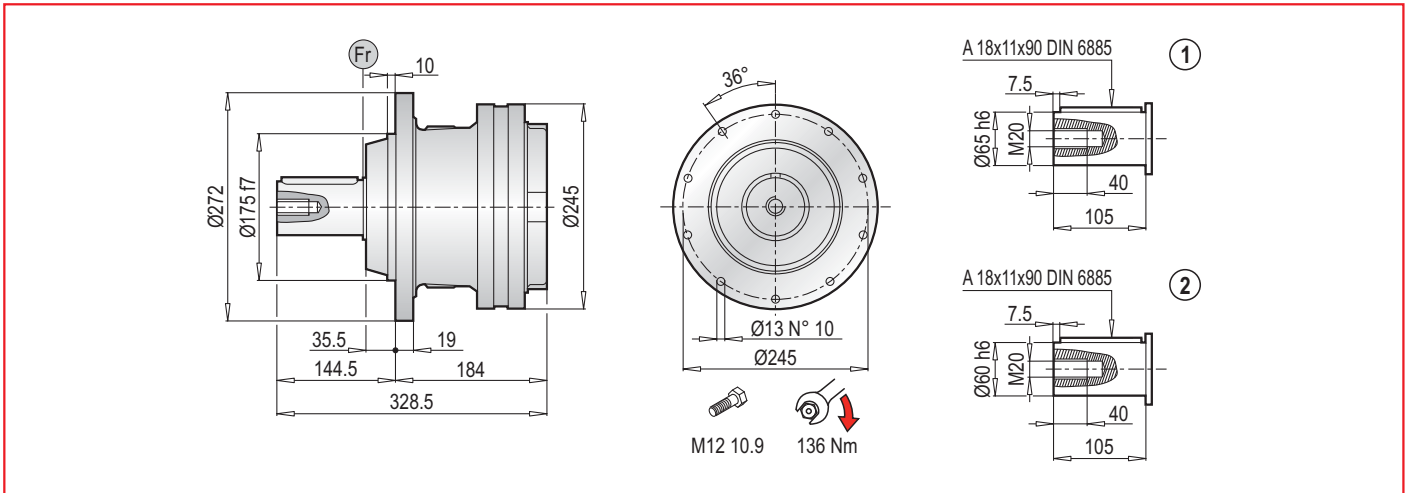

PL 5000 PC - Elektrik Motor Adaptörleri (IEC) / Electric Motor Couplings (IEC) / Anbauvorrichtung Für Elektromotore (IEC) / Predisposizioni Per Motori Elettrici (IEC) / Adaptations Pour Moteurs Electriques (IEC) / Acoplamientos Para Motores Eléctricos (IEC)

PL	IEC 63			IEC 71			IEC 80			IEC 90			IEC 100		
	L _T	Z	ØD	L _T	Z	ØD	L _T	Z	ØD	L _T	Z	ØD	L _T	Z	ØD
5001	220	36	140	220	36	160	240	56	200	240	56	200	250	66	250
5002	281			281			301			301			311		
5003	329			329			349			349			359		
5004	377			377			397			397			407		

PL	IEC 112			IEC 132			IEC 160			IEC 180		
	L _T	Z	ØD	L _T	Z	ØD	L _T	Z	ØD	L _T	Z	ØD
5001	250	66	250	284	100	300	323	139	350	323	139	350
5002	311			345			384			-		
5003	359			393			432			-		
5004	407			441			-			-		

PL	IEC ~ Kg								
	63	71	80	90	100	112	132	160	180
5001	48	48	50	50	51	51	55	65	56
5002	56	56	58	58	59	59	63	73	-
5003	62	62	64	64	65	65	69	79	-
5004	68	68	70	70	71	71	-	-	-

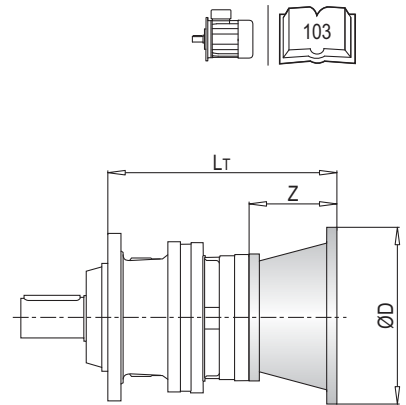

PL 5000 PC - Giriş Milleri / Input Shafts / Antriebswellen / Alberi Entrata / Arbres D'entree / Ejes De Entrada

PL	EL C 28				EL C 42				EML 42				EML 1"3/8 Z6				EM 65				EM 1"3/8 Z6			
	L _T	Z	L	Ød	L _T	Z	L	Ød	L _T	Z	L	Ød	L _T	Z	L	Ød	L _T	Z	L	Ød	L _T	Z	L	Ød
5001	248	64	50	28	248	64	82	42	278	94	82	42	278	94	106	1"3/8	319	121.5	105	65	319	121.5	105	1"3/8
5002	309				309				339				339				-							
5003	357				357				387				387				-							
5004	405				405				435				435				-							

PL	EP 65				PL	~ Kg						
	L _T	Z	L	Ød		EL C 28	EL C 42	EML 42	EML 1"3/8 Z6	EM 65	EM 1"3/8 Z6	EP 65
5001	350.5	153	105	65	5001	48.5	49.0	52.0	52.0	60.0	60.0	69.0
5002	-	-	-	-	5002	56.5	57.0	60.0	60.0	-	-	-
5003	-	-	-	-	5003	62.5	63.0	66.0	66.0	-	-	-
5004	-	-	-	-	5004	68.5	69.0	72.0	72.0	-	-	-

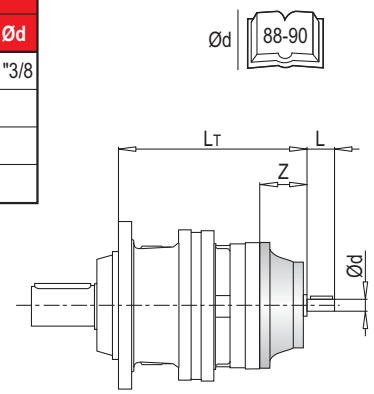

PL 5000 PC - Sonsuz Dişli Redüktör Adaptörleri (PMRV/PRV) / Worm Gearbox Adaptors (PMRV/PRV) / Anschluss Für Schneckengetriebe (PMRV/PRV) / Predisposizioni Per Riduttori A Vite Senza Fine (PMRV/PRV) / Adaptation Pour Reducteurs A Vis Sans Fin (PMRV/PRV) / Acoplamiento Para Reductores De Tornillo Sin Fin (PMRV/PRV)

PL	PMRV/PRV 050					PMRV/PRV 063					PMRV/PRV 075				
	LM	l	h	MA	G	LM	l	h	MA	G	LM	l	h	MA	G
5001	309.5					319					298				
5002	370.5	50	110	60	80	380	63	135	72	95	359	75	161	86	112.5
5003	418.5					428					407				
5004	466.5					476					455				

PL	PMRV/PRV 090					PMRV/PRV 110					PMRV/PRV 130				
	LM	l	h	MA	G	LM	l	h	MA	G	LM	l	h	MA	G
5001	308					335.5	110	237.5	127.5	160	343	130	277.5	147.5	180
5002	369	90	193	103	129.5	-					-				
5003	417					-					-				
5004	465					-					-				

PL	PMRV/PRV ~ Kg					
	050	063	075	090	110	130
5001	51	54.5	57	62	89	106
5002	59	62.5	65	70	-	-
5003	65	68.5	71	76	-	-
5004	71	74.5	77	82	-	-

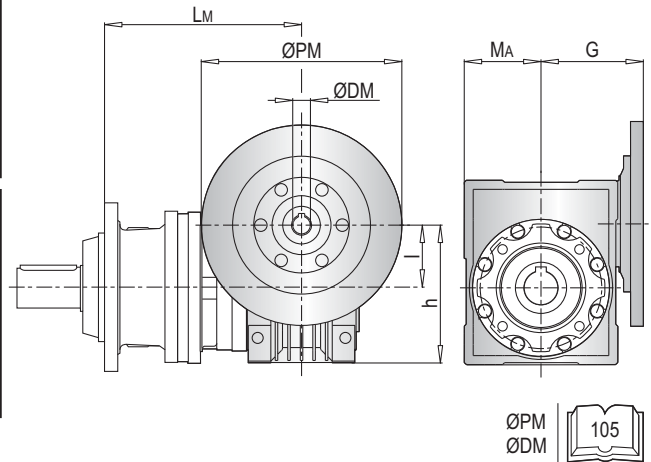

PLB 5000 PC - Elektrik Motor Adaptörleri (IEC) / Electric Motor Couplings (IEC) / Anbauvorrichtung Für Elektromotore (IEC) / Predisposizioni Per Motori Elettrici (IEC) / Adaptations Pour Moteurs Electriques (IEC) / Acoplamientos Para Motores Eléctricos (IEC)

PLB	IEC 80				IEC 90				IEC 100				IEC 112			
	A	L _T	Z	ØD	A	L _T	Z	ØD	A	L _T	Z	ØD	A	L _T	Z	ØD
5002	285.5	296			285.5	296			285.5	306			285.5	306		
5003	320	216	56	200	320	216	56	200	320	226	66	250	320	226	66	250
5004	368				368				368				368			

PLB	IEC 132				IEC 160			
	A	L _T	Z	ØD	A	L _T	Z	ØD
5002	285.5	340			285.5	379	139	350
5003	320	260	100	300	-			
5004	368				-			

PLB	IEC ~ Kg					
	80	90	100	112	132	160
5002	68	68	69	69	73	83
5003	76	76	77	77	81	-
5004	82	82	83	83	87	-

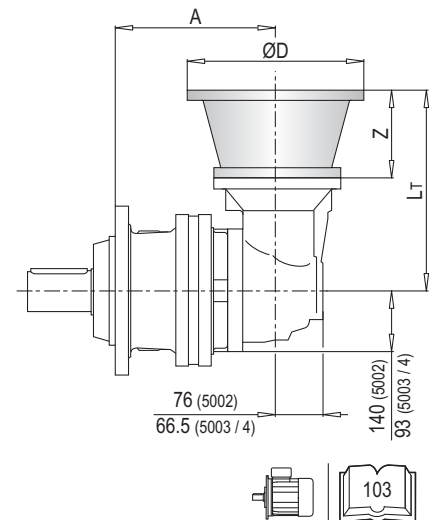

PLB 5000 PC - Giriş Milleri / Input Shafts / Antriebswellen / Alberi Entrata / Arbres D'entree / Ejes De Entrada

PLB	EL C 28					EL C 42					EML 42					EML 1 3/8 Z6					EM 65					
	A	L _T	Z	L	Ød	A	L _T	Z	L	Ød	A	L _T	Z	L	Ød	A	L _T	Z	L	Ød	A	L _T	Z	L	Ød	
5002	285.5	304				285.5	304				285.5	334				285.5	334				285.5	377.5				
5003	320	224	64	50	28	320	224	64	82	42	320	254	94	82	42	320	254	94	106	1 3/8	320	297.5	121.5	105	65	
5004	368					368					368					368										

PLB	EM 1 3/8 Z6					EP 65				
	A	L _T	Z	L	Ød	A	L _T	Z	L	Ød
5002	285.5	377.5				285.5	409			
5003	320	297.5	121.5	105	1 3/8	320	329	153	105	65
5004	368					368				

PLB	~ Kg						
	EL C 28	EL C 42	EML 42	EML 1 3/8 Z6	EM 65	EM 1 3/8 Z6	EP 65
5002	66.5	67.0	70.0	70.0	78.0	78.0	87.0
5003	74.5	75.0	78.0	78.0	86.0	86.0	95.0
5004	80.5	81.0	84.0	84.0	92.0	92.0	101.0

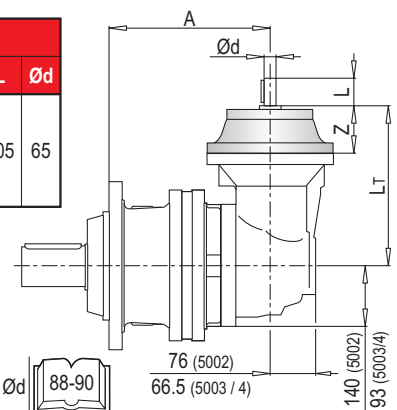

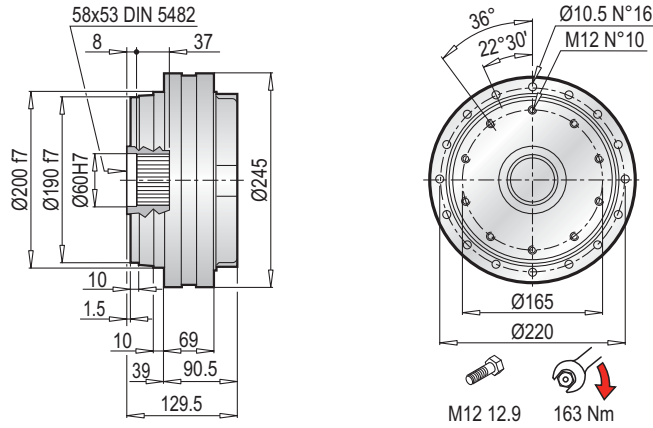

Aksesuarlar
Accessories
Zubehör
Accessori
Accessoires
Accesorios



PL 5000 F - Elektrik Motor Adaptörleri (IEC) / Electric Motor Couplings (IEC) / Anbauvorrichtung Für Elektromotore (IEC) / Predisposizioni Per Motori Elettrici (IEC) / Adaptations Pour Moteurs Electriques (IEC) / Acoplamientos Para Motores Eléctricos (IEC)

PL	IEC 63			IEC 71			IEC 80			IEC 90			IEC 100		
	L _T	Z	ØD	L _T	Z	ØD	L _T	Z	ØD	L _T	Z	ØD	L _T	Z	ØD
5001	126.5	36	140	126.5	36	160	146.5	56	200	146.5	56	200	156.5	66	250
5002	187.5			187.5			207.5			207.5			217.5		
5003	235.5			235.5			255.5			255.5			265.5		
5004	283.5			283.5			303.5			303.5			313.5		

PL	IEC 112			IEC 132			IEC 160			IEC 180		
	L _T	Z	ØD	L _T	Z	ØD	L _T	Z	ØD	L _T	Z	ØD
5001	156.5	66	250	190.5	100	300	229.5	139	350	229.5	139	350
5002	217.5			251.5			290.5			-		
5003	265.5			299.5			338.5			-		
5004	313.5			347.5			-			-		

PL	IEC ~ Kg								
	63	71	80	90	100	112	132	160	180
5001	31	31	33	33	34	34	38	48	48
5002	38	38	40	40	41	41	45	55	-
5003	44	44	46	46	47	47	51	61	-
5004	50	50	52	52	53	53	-	-	-

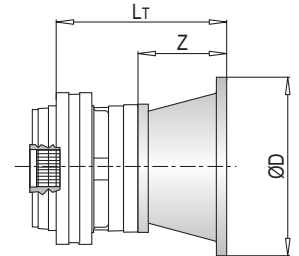

PL 5000 F - Giriş Milleri / Input Shafts / Antriebswellen / Alberi Entrata / Arbres D'entree / Ejes De Entrada

PL	EL C 28				EL C 42				EML 42				EML 1"3/8 Z6				EM 65				EM 1"3/8 Z6			
	L _T	Z	L	Ød	L _T	Z	L	Ød	L _T	Z	L	Ød	L _T	Z	L	Ød	L _T	Z	L	Ød	L _T	Z	L	Ød
5001	154.5	64	50	28	154.5	64	82	42	184.5	94	82	42	184.5	94	106	1"3/8	225.5	121.5	105	65	225.5	121.5	105	1"3/8
5002	215.5				215.5				245.5				245.5				-							
5003	263.5				263.5				293.5				293.5				-							
5004	311.5				311.5				341.5				341.5				-							

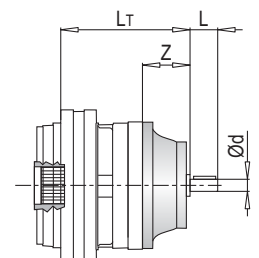

PL	EP 65				PL	~ Kg						
	L _T	Z	L	Ød		EL C 28	EL C 42	EML 42	EML 1"3/8 Z6	EM 65	EM 1"3/8 Z6	EP 65
5001	257	153	105	65	5001	31.5	32.0	35.0	35.0	43.0	43.0	52.0
5002	-	-	-	-	5002	38.5	39.0	42.0	42.0	-	-	-
5003	-	-	-	-	5003	44.5	45.0	48.0	48.0	-	-	-
5004	-	-	-	-	5004	50.5	51.0	54.0	54.0	-	-	-

PL 5000 F - Sonsuz Dişli Redüktör Adaptörleri (PMRV/PRV) / Worm Gearbox Adaptors (PMRV/PRV) / Anschluss Für Schneckengetriebe (PMRV/PRV) / Predisposizioni Per Riduttori A Vite Senza Fine (PMRV/PRV) / Adaptation Pour Reducteurs A Vis Sans Fin (PMRV/PRV) / Acoplamiento Para Reductores De Tornillo Sin Fin (PMRV/PRV)

PL	PMRV/PRV 050					PMRV/PRV 063					PMRV/PRV 075				
	LM	I	h	MA	G	LM	I	h	MA	G	LM	I	h	MA	G
5001	216					225.5					204.5				
5002	277	50	110	60	80	286.5	63	135	72	95	265.5	75	161	86	112.5
5003	285					334.5					313.5				
5004	373					382.5					361.5				

PL	PMRV/PRV 090					PMRV/PRV 110					PMRV/PRV 130				
	LM	I	h	MA	G	LM	I	h	MA	G	LM	I	h	MA	G
5001	214.5					242	110	237.5	127.5	160	249.5	130	277.5	147.5	180
5002	275.5	90	193	103	129.5	-	-	-	-	-	-	-	-	-	-
5003	323.5					-	-	-	-	-	-	-	-	-	-
5004	371.5					-	-	-	-	-	-	-	-	-	-

PL	PMRV/PRV ~ Kg					
	050	063	075	090	110	130
5001	34	37.5	40	45	72	89
5002	41	44.5	47	52	-	-
5003	47	50.5	53	58	-	-
5004	53	56.5	59	64	-	-

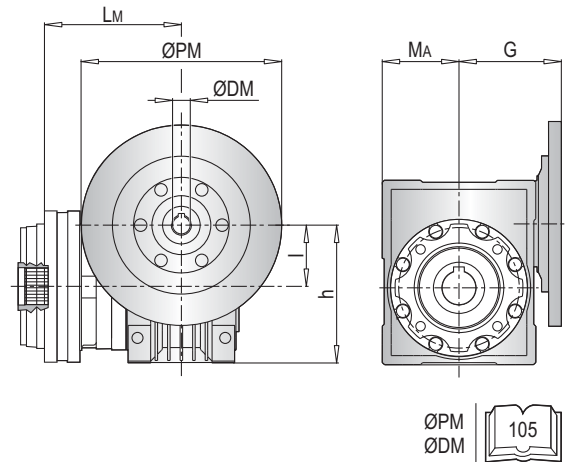

PLB 5000 F - Elektrik Motor Adaptörleri (IEC) / Electric Motor Couplings (IEC) / Anbauvorrichtung Für Elektromotore (IEC) / Predisposizioni Per Motori Elettrici (IEC) / Adaptations Pour Moteurs Electriques (IEC) / Acoplamientos Para Motores Eléctricos (IEC)

PLB	IEC 80				IEC 90				IEC 100				IEC 112			
	A	L _T	Z	ØD	A	L _T	Z	ØD	A	L _T	Z	ØD	A	L _T	Z	ØD
5002	192	296			192	296			192	306			192	306		
5003	226.5	216	56	200	226.5	216	56	200	226.5	226	66	250	226.5	226	66	250
5004	274.5				274.5				274.5				274.5			

PLB	IEC 132				IEC 160			
	A	L _T	Z	ØD	A	L _T	Z	ØD
5002	192	340			192	379	139	350
5003	226.5	260	100	300	-	-	-	-
5004	274.5				-	-	-	-

PLB	IEC ~ Kg					
	80	90	100	112	132	160
5002	51	51	52	52	56	66
5003	58	58	59	59	63	-
5004	64	64	65	65	69	-

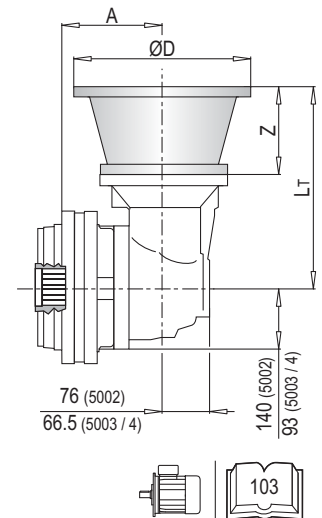

PLB 5000 F - Giriş Milleri / Input Shafts / Antriebswellen / Alberi Entrata / Arbres D'entree / Ejes De Entrada

PLB	EL C 28					EL C 42					EML 42					EML 1"3/8 Z6					EM 65				
	A	L _T	Z	L	Ød	A	L _T	Z	L	Ød	A	L _T	Z	L	Ød	A	L _T	Z	L	Ød	A	L _T	Z	L	Ød
5002	192	304				192	304				192	334	94	82	42	192	334	94	106	1"3/8	192	377.5	121.5	105	65
5003	226.5	224	64	50	28	226.5	224	64	82	42	226.5	254	94	82	42	226.5	254	94	106	1"3/8	226.5	297.5	121.5	105	65
5004	274.5					274.5					274.5					274.5					274.5				

PLB	EM 1"3/8 Z6					EP 65				
	A	L _T	Z	L	Ød	A	L _T	Z	L	Ød
5002	192	377.5				192	409			
5003	226.5	297.5	121.5	105	1"3/8	226.5	329	153	105	65
5004	274.5					274.5				

PLB	~ Kg						
	EL C 28	EL C 42	EML 42	EML 1"3/8 Z6	EM 65	EM 1"3/8 Z6	EP 65
5002	49.5	50.0	53.0	53.0	61.0	61.0	70.0
5003	56.5	57.0	60.0	60.0	68.0	68.0	77.0
5004	62.5	63.0	66.0	66.0	74.0	74.0	83.0

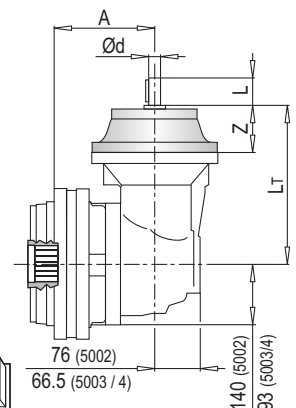

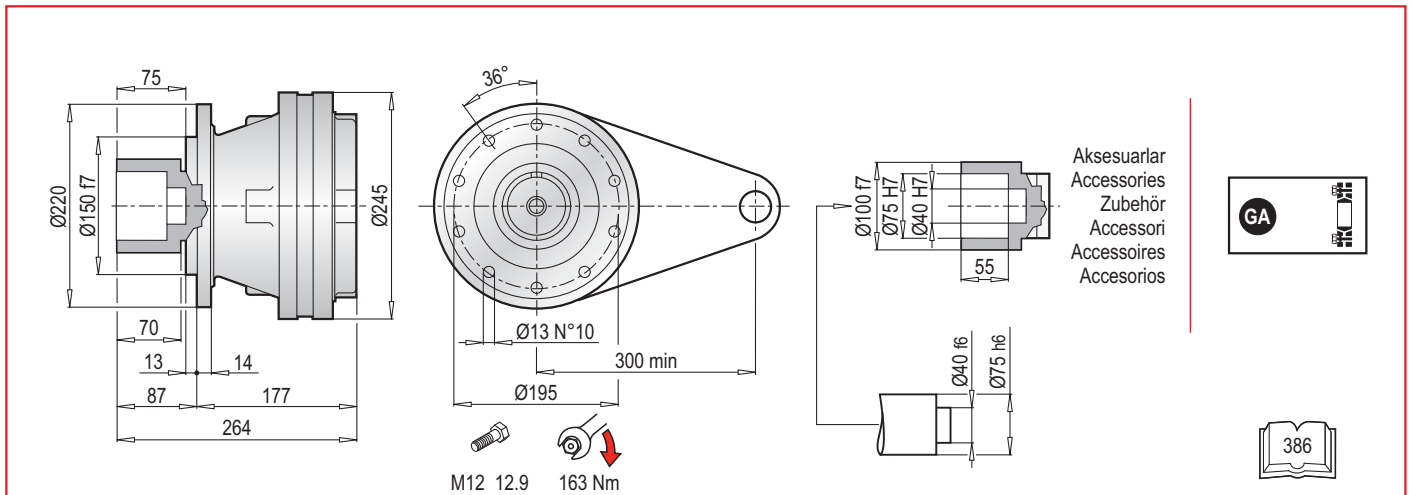

PL 5000 FS - Elektrik Motor Adaptörleri (IEC) / Electric Motor Couplings (IEC) / Anbauvorrichtung Für Elektromotore (IEC) / Predisposizioni Per Motori Elettrici (IEC) / Adaptations Pour Moteurs Electriques (IEC) / Acoplamientos Para Motores Eléctricos (IEC)

PL	IEC 63			IEC 71			IEC 80			IEC 90			IEC 100		
	L _T	Z	ØD	L _T	Z	ØD	L _T	Z	ØD	L _T	Z	ØD	L _T	Z	ØD
5001	213			213			233			233			243		
5002	274	36	140	274	36	160	294	56	200	294	56	200	304	66	250
5003	322			322			342			342			352		
5004	370			370			390			390			400		

PL	IEC 112			IEC 132			IEC 160			IEC 180		
	L _T	Z	ØD	L _T	Z	ØD	L _T	Z	ØD	L _T	Z	ØD
5001	243			277			316			316	139	350
5002	304	66	250	338	100	300	377	139	350	-		
5003	352			386			425			-		
5004	400			434			-					

PL	IEC ~ Kg								
	63	71	80	90	100	112	132	160	180
5001	41	41	43	43	44	44	48	58	58
5002	49	49	51	51	52	52	56	66	-
5003	55	55	57	57	58	58	62	72	-
5004	61	61	63	63	64	64	68	-	-

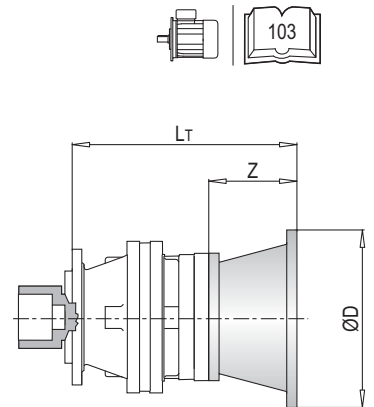

PL 5000 FS - Giriş Milleri / Input Shafts / Antriebswellen / Alberi Entrata / Arbres D'entree / Ejes De Entrada

PL	EL C 28				EL C 42				EML 42				EML 1"3/8 Z6				EM 65				EM 1"3/8 Z6			
	L _T	Z	L	Ød	L _T	Z	L	Ød	L _T	Z	L	Ød	L _T	Z	L	Ød	L _T	Z	L	Ød	L _T	Z	L	Ød
5001	241				241				271				271				312	121.5	105	65	312	121.5	105	1"3/8
5002	302	64	50	28	302	64	82	42	332	94	82	42	332	94	106	1"3/8	-				-			
5003	350				350				380				380				-							
5004	398				398				428				428				-							

PL	EP 65				PL	~ Kg						
	L _T	Z	L	Ød		EL C 28	EL C 42	EML 42	EML 1"3/8 Z6	EM 65	EM 1"3/8 Z6	EP 65
5001	343.5	153	105	65	5001	41.5	42.0	45.0	45.0	53.0	53.0	62.0
5002	-	-	-	-	5002	49.5	50.0	53.0	53.0	-	-	-
5003	-	-	-	-	5003	55.5	56.0	59.0	59.0	-	-	-
5004	-	-	-	-	5004	61.5	62.0	65.0	65.0	-	-	-

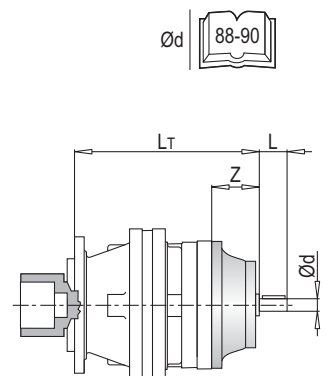

PL 5000 FS - Sonsuz Dişli Redüktör Adaptörleri (PMRV/PRV) / Worm Gearbox Adaptors (PMRV/PRV) / Anschluss Für Schneckengetriebe (PMRV/PRV) / Predisposizioni Per Riduttori A Vite Senza Fine (PMRV/PRV) / Adaptation Pour Reducteurs A Vis Sans Fin (PMRV/PRV) / Acoplamiento Para Reductores De Tornillo Sin Fin (PMRV/PRV)

PL	PMRV/PRV 050					PMRV/PRV 063					PMRV/PRV 075				
	LM	l	h	MA	G	LM	l	h	MA	G	LM	l	h	MA	G
5001	302.5					312					291				
5002	363.5	50	110	60	80	473	63	135	72	95	352	75	161	86	112.5
5003	411.5					421					400				
5004	459.5					469					448				

PL	PMRV/PRV 090					PMRV/PRV 110					PMRV/PRV 130				
	LM	l	h	MA	G	LM	l	h	MA	G	LM	l	h	MA	G
5001	301					315	110	237.5	127.5	160	322.5	130	277.5	147.5	180
5002	362	90	193	103	129.5	-	-	-	-	-	-	-	-	-	-
5003	410					-	-	-	-	-	-	-	-	-	-
5004	458					-	-	-	-	-	-	-	-	-	-

PL	PMRV/PRV ~ Kg					
	050	063	075	090	110	130
5001	44	47.5	50	55	82	99
5002	52	55.5	58	63	-	-
5003	58	61.5	64	69	-	-
5004	64	67.5	70	75	-	-

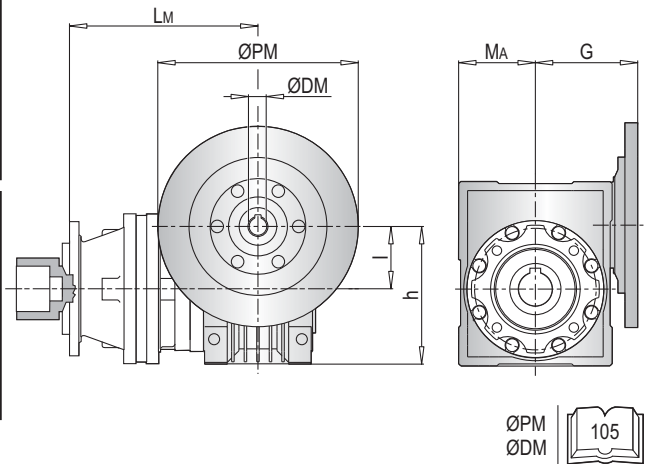

PLB 5000 FS - Elektrik Motor Adaptörleri (IEC) / Electric Motor Couplings (IEC) / Anbauvorrichtung Für Elektromotore (IEC) / Predisposizioni Per Motori Elettrici (IEC) / Adaptations Pour Moteurs Electriques (IEC) / Acoplamientos Para Motores Eléctricos (IEC)

PLB	IEC 80				IEC 90				IEC 100				IEC 112			
	A	L _T	Z	ØD	A	L _T	Z	ØD	A	L _T	Z	ØD	A	L _T	Z	ØD
5002	278.5	296			278.5	296			278.5	306			278.5	306		
5003	313		56	200	313		56	200	313		66	250	313		66	250
5004	361	216			361	216			361	226			361	226		

PLB	IEC 132				IEC 160			
	A	L _T	Z	ØD	A	L _T	Z	ØD
5002	278.5	340			278.5	379	139	350
5003	313		100	300	-	-	-	-
5004	361	260			-	-	-	-

PLB	IEC ~ Kg					
	80	90	100	112	132	160
5002	61	61	62	62	66	76
5003	69	69	70	70	74	-
5004	75	75	76	76	80	-

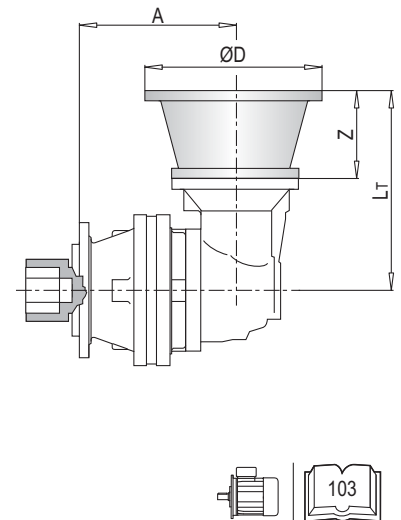

PLB 5000 FS - Giriş Milleri / Input Shafts / Antriebswellen / Alberi Entrata / Arbres D'entree / Ejes De Entrada

PLB	EL C 28					EL C 42					EML 42					EML 1"3/8 Z6					EM 65					
	A	L _T	Z	L	Ød	A	L _T	Z	L	Ød	A	L _T	Z	L	Ød	A	L _T	Z	L	Ød	A	L _T	Z	L	Ød	
5002	278.5	304				278.5	304				278.5	334				278.5	334				278.5	377.5				
5003	313		64	50	28	313		64	82	42	313		94	82	42	313		94	106	1"3/8	313		121.5	105	65	
5004	361	224				361	224				361	254				361	254				361	297.5				

PLB	EM 1"3/8 Z6					EP 65				
	A	L _T	Z	L	Ød	A	L _T	Z	L	Ød
5002	278.5	377.5				278.5	409			
5003	313		121.5	105	1"3/8	313		153	105	65
5004	361	297.5				361	329			

PLB	~ Kg						
	EL C 28	EL C 42	EML 42	EML 1"3/8 Z6	EM 65	EM 1"3/8 Z6	EP 65
5002	59.5	60.0	63.0	63.0	71.0	71.0	80.0
5003	67.5	68.0	71.0	71.0	79.0	79.0	88.0
5004	73.5	74.0	77.0	77.0	85.0	85.0	94.0

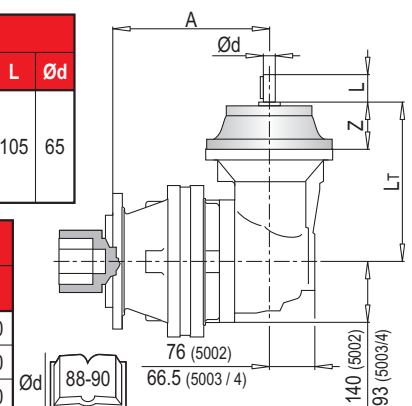

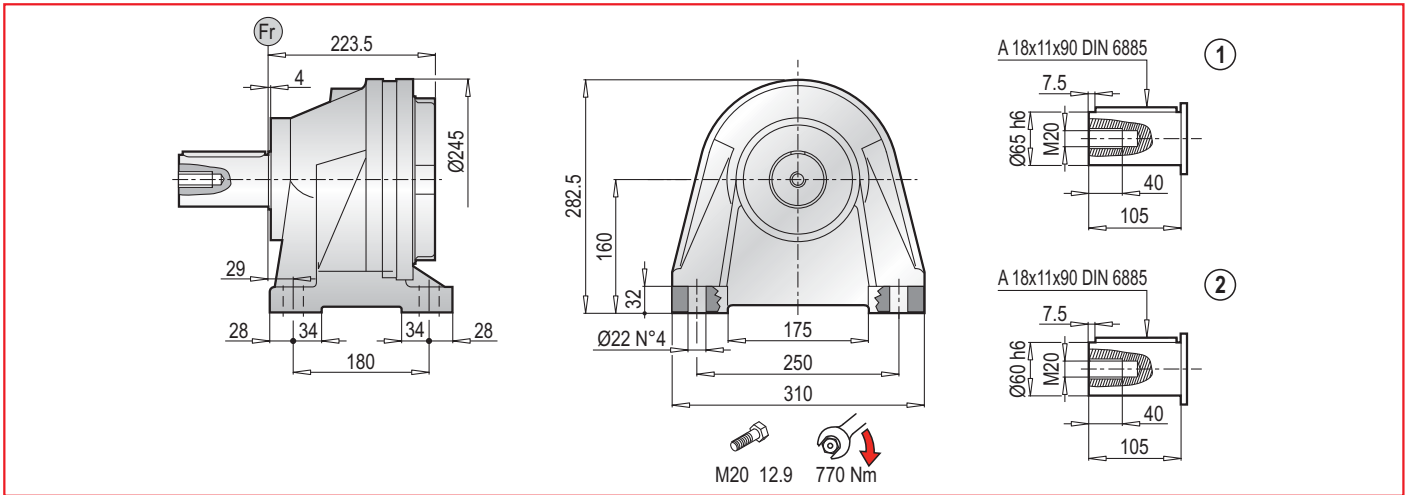

PL 5000 CPC - Elektrik Motor Adaptörleri (IEC) / Electric Motor Couplings (IEC) / Anbauvorrichtung Für Elektromotore (IEC) / Predisposizioni Per Motori Elettrici (IEC) / Adaptations Pour Moteurs Electriques (IEC) / Acoplamientos Para Motores Eléctricos (IEC)

PL	IEC 63			IEC 71			IEC 80			IEC 90			IEC 100		
	L _T	Z	ØD	L _T	Z	ØD	L _T	Z	ØD	L _T	Z	ØD	L _T	Z	ØD
5001	259.5	36	140	259.5	36	160	279.5	56	200	279.5	56	200	289.5	66	250
5002	320.5			320.5			340.5			340.5			350.5		
5003	368.5			368.5			388.5			388.5			398.5		
5004	416.5			416.5			436.5			436.5			446.5		

PL	IEC 112			IEC 132			IEC 160			IEC 180		
	L _T	Z	ØD	L _T	Z	ØD	L _T	Z	ØD	L _T	Z	ØD
5001	289.5	66	250	323.5	100	300	362.5	139	350	362.5	139	350
5002	350.5			384.5			423.5			-		
5003	398.5			432.5			471.5			-		
5004	446.5			480.5			-			-		

PL	IEC ~ Kg								
	63	71	80	90	100	112	132	160	180
5001	52	52	54	54	55	55	59	69	69
5002	60	60	62	62	63	63	67	77	-
5003	66	66	68	68	69	69	73	83	-
5004	72	72	74	74	75	75	79	-	-

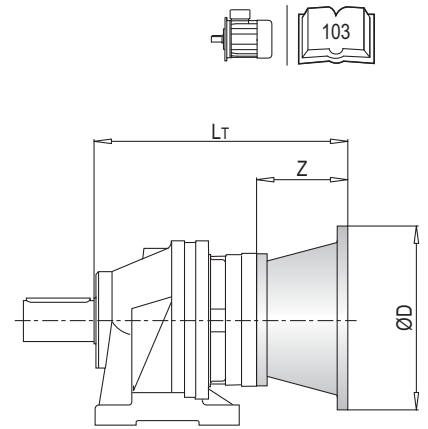

PL 5000 CPC - Giriş Milleri / Input Shafts / Antriebswellen / Alberi Entrata / Arbres D'entree / Ejes De Entrada

PL	EL C 28				EL C 42				EML 42				EML 1"3/8 Z6				EM 65				EM 1"3/8 Z6			
	L _T	Z	L	Ød	L _T	Z	L	Ød	L _T	Z	L	Ød	L _T	Z	L	Ød	L _T	Z	L	Ød	L _T	Z	L	Ød
5001	287.5	64	50	28	287.5	64	82	42	317.5	94	82	42	317.5	94	106	1"3/8	358.5	121.5	105	65	358.5	121.5	105	1"3/8
5002	348.5				348.5				378.5				378.5				-							
5003	396.5				396.5				426.5				426.5				-							
5004	444.5				444.5				474.5				474.5				-							

PL	EP 65				PL	~ Kg						
	L _T	Z	L	Ød		EL C 28	EL C 42	EML 42	EML 1"3/8 Z6	EM 65	EM 1"3/8 Z6	EP 65
5001	390	153	105	65	5001	52.5	53.0	56.0	56.0	64.0	64.0	73.0
5002	-	-	-	-	5002	60.5	61.0	64.0	64.0	-	-	-
5003	-	-	-	-	5003	66.5	67.0	70.0	70.0	-	-	-
5004	-	-	-	-	5004	72.5	73.0	76.0	76.0	-	-	-

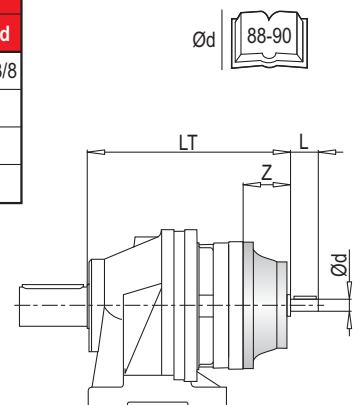

PL 5000 CPC - Sonsuz Dişli Redüktör Adaptörleri (PMRV/PRV) / Worm Gearbox Adaptors (PMRV/PRV) / Anschluss Für Schneckengetriebe (PMRV/PRV) / Predisposizioni Per Riduttori A Vite Senza Fine (PMRV/PRV) / Adaptation Pour Reducteurs A Vis Sans Fin (PMRV/PRV) / Acoplamiento Para Reductores De Tornillo Sin Fin (PMRV/PRV)

PL	PMRV/PRV 050					PMRV/PRV 063					PMRV/PRV 075				
	Lm	I	h	MA	G	Lm	I	h	MA	G	Lm	I	h	MA	G
5001	349					358.5					337.5				
5002	410	50	110	60	80	419.5	63	135	72	95	398.5	75	161	86	112.5
5003	458					467.5					446.5				
5004	506					515.5					494.5				

PL	PMRV/PRV 090					PMRV/PRV 110					PMRV/PRV 130				
	Lm	I	h	MA	G	Lm	I	h	MA	G	Lm	I	h	MA	G
5001	347.5	90	193	103	129.5	361.5	110	237.5	127.5	160	369	130	277.5	147.5	180
5002	408.5					-	-	-	-						
5003	456.5					-	-	-	-						
5004	504.5					-	-	-	-						

PL	PMRV/PRV ~ Kg					
	050	063	075	090	110	130
5001	55	58.5	61	66	93	110
5002	63	66.5	69	74	-	-
5003	69	72.5	75	79	-	-
5004	75	78.5	81	85	-	-

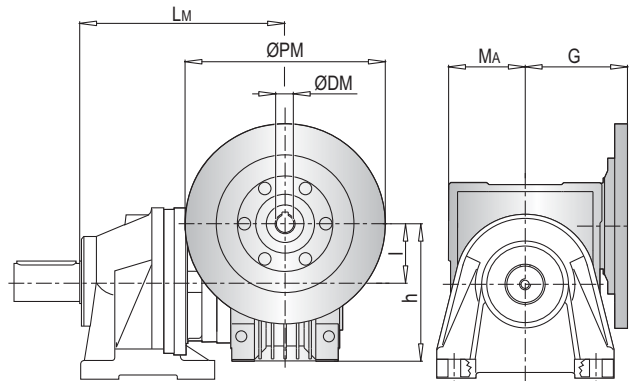

PLB 5000 CPC - Elektrik Motor Adaptörleri (IEC) / Electric Motor Couplings (IEC) / Anbauvorrichtung Für Elektromotore (IEC) / Predisposizioni Per Motori Elettrici (IEC) / Adaptations Pour Moteurs Electriques (IEC) / Acoplamientos Para Motores Eléctricos (IEC)

PLB	IEC 80				IEC 90				IEC 100				IEC 112			
	A	Lt	Z	ØD	A	Lt	Z	ØD	A	Lt	Z	ØD	A	Lt	Z	ØD
5002	325	296			325	296			325	306			325	306		
5003	359.5	216	56	200	359.5	216	56	200	359.5	226	66	250	359.5	226	66	250
5004	407.5				407.5				407.5							

PLB	IEC 132				IEC 160			
	A	Lt	Z	ØD	A	Lt	Z	ØD
5002	325	340			325	379	139	350
5003	359.5	260	100	300	-			
5004	407.5				-			

PLB	IEC ~ Kg					
	80	90	100	112	132	160
5002	72	72	73	73	77	87
5003	80	80	81	81	85	-
5004	86	86	87	87	91	-

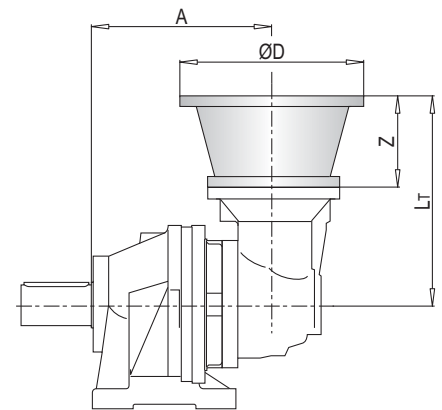

PLB 5000 CPC - Giriş Milleri / Input Shafts / Antriebswellen / Alberi Entrata / Arbres D'entree / Ejes De Entrada

PLB	EL C 28					EL C 42					EML 42					EML 1"3/8 Z6					EM 65					
	A	Lt	Z	L	Ød	A	Lt	Z	L	Ød	A	Lt	Z	L	Ød	A	Lt	Z	L	Ød	A	Lt	Z	L	Ød	
5002	325	304				325	304				325	334				325	334				325	377.5				
5003	359.5	224	64	50	28	359.5	224	64	82	42	359.5	254	94	82	42	359.5	254	94	106	1"3/8	359.5	297.5	121.5	105	65	
5004	407.5					407.5					407.5					407.5										

PLB	EM 1"3/8 Z6					EP 65				
	A	Lt	Z	L	Ød	A	Lt	Z	L	Ød
5002	325	377.5				325	409			
5003	359.5	297.5	121.5	105	1"3/8	359.5	329	153	105	65
5004	407.5					407.5				

PLB	~ Kg						
	EL C 28	EL C 42	EML 42	EML 1"3/8 Z6	EM 65	EM 1"3/8 Z6	EP 65
5002	70.5	71.0	74.0	74.0	82.0	82.0	91.0
5003	78.5	79.0	82.0	82.0	90.0	90.0	99.0
5004	84.5	85.0	88.0	88.0	96.0	96.0	105.0

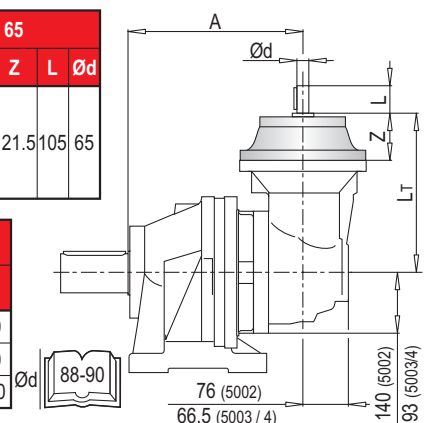

PL	~ Kg
5001	34
5002	42
5003	48
5004	54

PL	~ Kg
5001	34
5002	42
5003	48
5004	54

PL	~ Kg
5001	43
5002	51
5003	57
5004	63

PL	~ Kg
5001	43
5002	51
5003	57
5004	63

PL	~ Kg
5001	26
5002	33
5003	39
5004	45

PL	~ Kg
5001	36
5002	44
5003	50
5004	56

PL	~ Kg
5001	47
5002	55
5003	61
5004	67

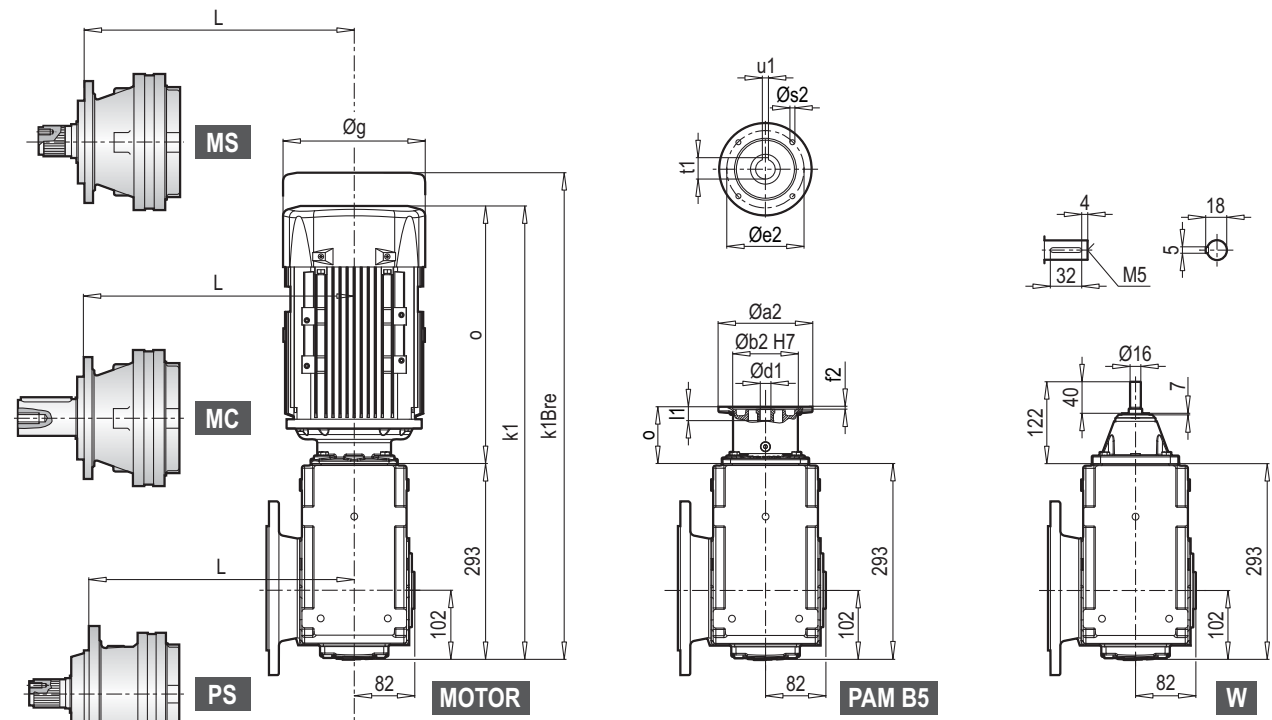

W ~ Kg	
PKD 2390	44

PL	L						
	MS	MC	PS	PC	F	FS	CPC
5001	339	339	346	346	253	339	386
5002	400	400	407	407	314	400	447
5003	448	448	455	455	362	448	495
5004	496	496	503	503	410	496	543

PKD 2390	MOTOR	g	g1	k1	k1Bre	o	~ Kg	
							MOTOR	PKD 2390
PKD 2390	63 M	124	111	491	543	198	63 M	44
	71 M	140	119	533	593	240	71 M	49
	80 M	159	127	560	622	267	80 M	51
	90 S	193	151	583	656	290	90 S	53
	90 L	193	151	603	676	310	90 L	55
	100 L	217	160	631	712	338	100 L	67
	112 M	232	168	676	756	383	112 M	74

PKD 2390	PAM B5	Øa2	Øb2	Øe2	f2	Øs2	Ød1	l1	t1	u1	o	~ Kg												
												PAM B5	PKD 2390											
												63	140	95	115	3.5	M8	11	23	12.8	4	85	63	42
												71	160	110	130	4.0	M8	14	30	16.3	5	55	71	42
												80	200	130	165	4.0	M10	19	40	21.8	6	74	80	43
												90	200	130	165	4.0	M10	24	50	27.3	8	74	90	43
100	250	180	215	5.0	M12	28	60	31.3	8	131.5	100	50												
112	250	180	215	5.0	M12	28	60	31.3	8	131.5	112	50												

~ Kg	
PAM B5	PKD 2390
63	42
71	42
80	43
90	43
100	50
112	50

PL	~ Kg
MS	
5001	34
5002	42
5003	48
5004	54

PL	~ Kg
MC	
5001	34
5002	42
5003	48
5004	54

PL	~ Kg
PS	
5001	43
5002	51
5003	57
5004	63

PL	~ Kg
PC	
5001	43
5002	51
5003	57
5004	63

PL	~ Kg
F	
5001	26
5002	33
5003	39
5004	45

PL	~ Kg
FS	
5001	36
5002	44
5003	50
5004	56

PL	~ Kg
CPC	
5001	47
5002	55
5003	61
5004	67

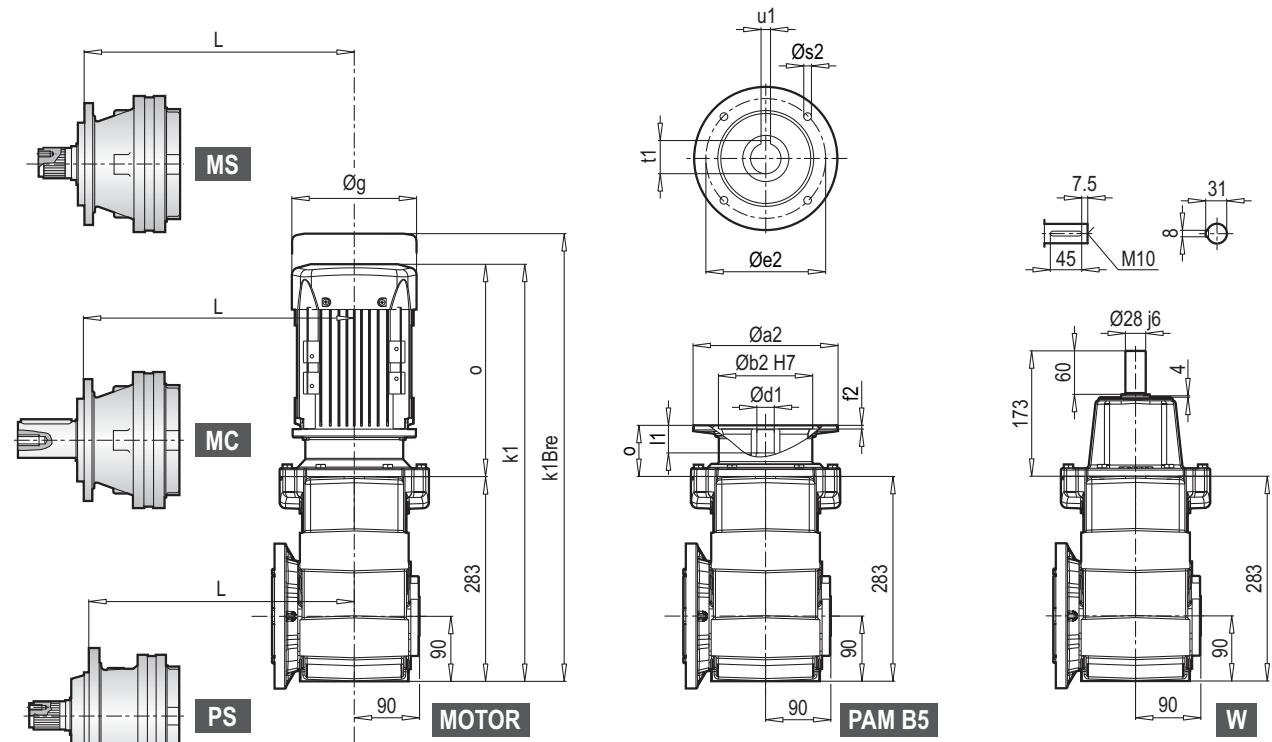

PL	L						
	MS	MC	PS	PC	F	FS	CPC
5001	339	339	346	346	253	339	386
5002	400	400	407	407	314	401	447
5003	448	448	455	455	362	448	495
5004	496	496	503	503	410	496	543

W ~ Kg	
K 40390	35

	MOTOR	g	g1	k1	k1Bre	o	~ Kg	
							MOTOR	K 40390
K 40390	80 M	159	127	530	592	247	80 M	38
	90 S	193	151	576	649	293	90 S	41
	90 L	193	151	596	669	313	90 L	43
	100 L	217	160	619	700	336	100 L	54
	112 M	232	168	672	752	389	112 M	61
	132 S	279	182	679	787	396	132 S	77
	132 M	279	182	714	855	431	132 M	88
	160 M	323	200	801	953	518	160 M	87

	PAM B5	Øa2	Øb2	Øe2	f2	Øs2	Ød1	l1	t1	u1	o	~ Kg	
												PAM B5	K 40390
K 40390	80	200	130	165	5	M10	19	42	21.8	6	70	80	33
	90	200	130	165	5	M10	24	52	27.3	8	70	90	33
	100	250	180	215	5.5	M12	28	62	31.3	8	85	100	35
	112	250	180	215	5.5	M12	28	62	31.3	8	85	112	35
	132	300	230	265	5.5	M12	38	82	41.3	10	110	132	39

AKSESUARLAR / ACCESSORIES / ZUBEHÖR / ACCESSORI / ACCESSOIRES / ACCESORIOS

YZ Pinyon / Pinion / Ritzel
Pignoni / Pignon / Piñones



A

Çıkış tipi Output type Abtriebs-version Versione Version Versión	M	Z	XM	A	B	C	D	E	F	G	K	Malzeme Material Materiale Matière Material	Kod Code Bestell-Nr. Codice Code Código	
A	M	8	13	0	68	-	8.5	22.5	120	60	60	-	18NiCrMo5	1071.218.042
	M	8	11	5	68	-	8.5	22.5	110.8	60	60	-	38NiCrMo4	1071.258.042
B	M	8	12	0	68	-	8	21	112.8	60	60	-	38NiCrMo4	1071.196.042
	P	10	14	3.2	103	116	9.5	22.5	162.4	60	60	105	18NiCrMo5	1071.298.042
A	M	8	15	0	68	-	8.5	22.5	136	60	60	-	38NiCrMo4	1071.163.042
	P	6	14	3	95	-	23	21	99.6	60	60	-	38NiCrMo4	1071.160.042
	P	10	11	8	90	-	8.5	22.5	142.1	60	60	-	18NiCrMo5	1071.297.042

B

FF Sabitleme rondelası / Stop bottom plate / Endscheibe /
Fondello di arresto / Bouchon de fermeture / Tapón de detención

Kod / Code
Bestell - Nr. / Codice
Code / Código
1075.015.000

BS Spline kaplin / Splined bushing / Innenverzahnte Buchse /
Boccola scanalata / Moyeu cannelé / Casquillo ranurado

MS Bestell - Nr. / Code
Kod / Codice
Code / Código
2171.101.076

PS Bestell - Nr. / Code
Kod / Codice
Code / Código
4171.101.076

Material / Material
Malzeme / Materiale
Matière / Material
UNI C40
SAE 1040
DIN Ck40

KB Spline mil / Splined rod / Außenverzahnte Welle /
Barra scanalata / Arbre cannelé / Barra ranurada

UNI 39NiCrMo3
Material / Material
Malzeme / Materiale
Matière / Material
Vergütet / Hardened and tempered
Sertleşmiş ve tavlanmış / Bonifié
Bonificado / Endurecido e temperado

Bestell - Nr. / Code
Kod / Codice
Code / Código
3071.181.042

FL Flanş / Flange / Flansch
Flangia / Bride / Brida

MS Bestell - Nr. / Code
Kod / Codice
Code / Código
2171.103.025

PS Bestell - Nr. / Code
Kod / Codice
Code / Código
4171.103.098

GA Konik sıkırma / Shrink disc / Schrumpfscheibe /
Giunto di attrito / Frette de serrage / Disco de contracción

Max. Drehmoment
Max. torque
Maksimum moment
Coppia max.
Couple max.
Momento máx.
7.5 kNm

Bestell - Nr. / Code
Kod / Codice
Code / Código
5109.100.000

TR

RADYAL YÜKLER (Fr)

Aşağıdaki grafikler istenilen n_2xh değerinin elde edilmesi için gerekli olan radyal yükleri ve K faktörlerini göstermektedir.

EN

RADIAL LOADS (Fr)

The following curves show the radial loads and the K factors to obtain the required n_2xh value.

DE

RADIALLAST (Fr)

In den nachstehenden Diagrammen ist die Radiallast und der Koeffizient K dargestellt und kann mit dem gewünschten Wert n_2xh verglichen werden.

IT

CARICHI RADIALI (Fr)

Nei diagrammi seguenti sono riportati i carichi radiali e i coefficienti K per rapportarli al valore n_2xh desiderato.

FR

CHARGES RADIALES (Fr)

Dans les diagrammes suivants sont indiqués les charges radiales et les facteurs K de façon à obtenir la valeur n_2xh désirée.

ES

CARGAS RADIALES (Fr)

En los siguientes diagramas se indican las cargas radiales y los coeficientes K para obtener el valor requerido n_2xh .

M - P - CPC*

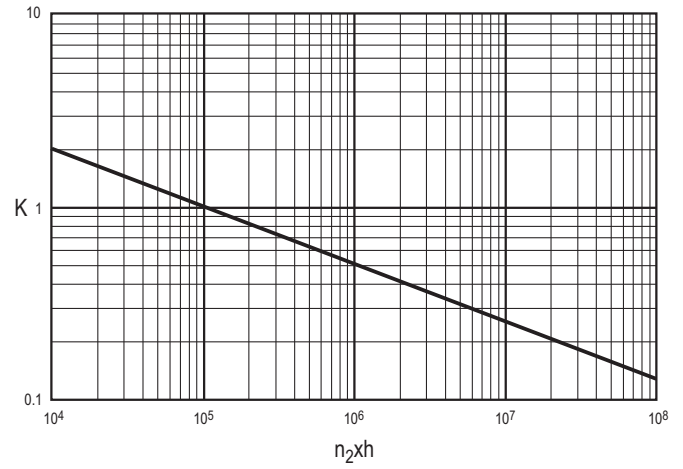
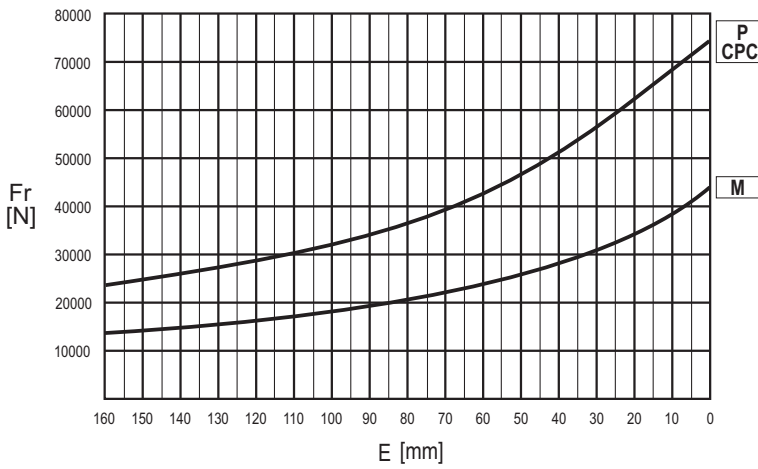

	n x h				
	10 ⁵	10 ⁴	10 ⁶	10 ⁷	10 ⁸
M - P	Fr		Fr • K		
CPC*	Fr • 0.75		Fr • K • 0.75		

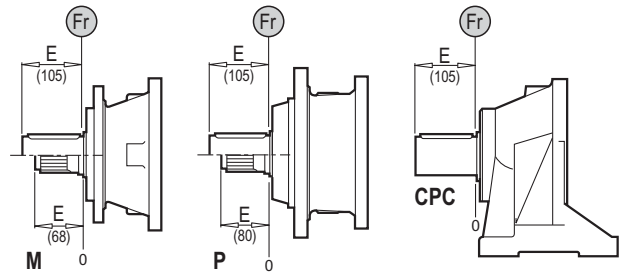

TR

EKSENEL YÜKLER (Fa)

Tabloda yer alan eksenel yük değerleri, çıkış tipine ve uygulamanın yük yönüne göre değişir.

EN

AXIAL LOADS (Fa)

The values of the axial loads in the table refer to the output versions and load direction of application.

DE

AXIALLAST (Fa)

Die dargestellten Werte der Axiallast basieren auf der Version und der applizierten Lastrichtung.

IT

CARICHI ASSIALI (Fa)

I valori dei carichi assiali indicati in tabella sono riferiti alle versioni e alla direzione di applicazione del carico.

FR

CHARGES AXIALES (Fa)

Les valeurs des charges axiales indiquées dans le tableau se réfèrent aux versions et à la direction d'application de la charge.

ES

CARGAS AXIALES (Fa)

Los valores de las cargas axiales indicados en la tabla se refieren a las versiones y a la dirección de aplicación de la carga.

Fa [N]	M	P - CPC	← →
		32000	
	32000	48000	

