

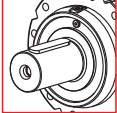

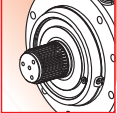





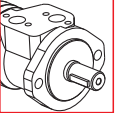
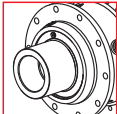
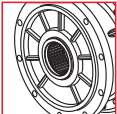
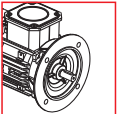
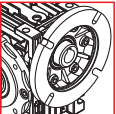
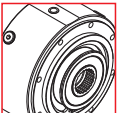
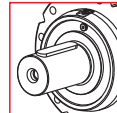
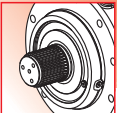
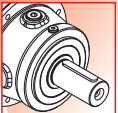
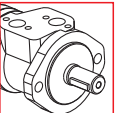
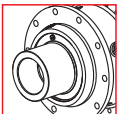
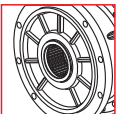
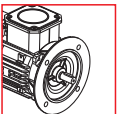

TEKNİK VERİLER / TECHNICAL DATA / TECHNISCHE DATEN / DATI TECNICI / DONNÉES TECHNIQUES / DATOS TÉCNICAS

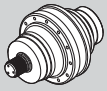
	i_{ges}	M_2max (n1: 1400rpm) (Nm)	OUTPUT		INPUT	
16001	3.56 ... 6.75	7440	 Ø100	 80x74 100x94 DIN 5482	 Ø28 - Ø42 Ø1"3/8 - Ø65	 Hydraulic Motor
16002	13.4 ... 48.9	9470	 Ø120	 80x74 DIN 5482	 Electric Motor	 Worm gearboxes
16003	57.6 ... 330.3	12960				
16004	352.0 ... 2229.7	17920			 Brake	

	i_{ges}	M_2max (n1: 1400rpm) (Nm)	OUTPUT		INPUT	
16002	12.3 ... 36.7	9280	 Ø100	 80x74 100x94 DIN 5482	 Ø28 - Ø42 Ø1"3/8 - Ø65	 Hydraulic Motor
16003	46.4 ... 266.4	12410	 Ø120	 80x74 DIN 5482	 Electric Motor	
16004	140.1 ... 969.0	16510			 Brake	

	Pt [kW]	n _{1max} [min ⁻¹]	i _{ges}	Mc [kNm]				Giriş- Input - Antrieb - Entrada - Entrée - Entrada		
				n ₂ x h	n ₂ x h	n ₂ x h	n ₂ x h			
				10.000	20.000	50.000	100.000	IEC (B5)	PMRV / PRV	EL - EML EM - EP - ET
PL 16001	40	2000	3.56	20.77	18.38	15.64	13.84	160 180 200 225	110 130	EM 65 EM 1"3/8 Z6 EP 65
			4.29	18.09	16.01	13.63	12.07			
			5.60	13.84	12.25	10.42	9.23			
			6.75	10.53	9.31	7.93	7.02			
PL 16002	23	2800	13.4	20.77	18.38	15.64	13.84	63 112 71 132 80 160 90 180 100	050 063 075 090 110 130	EL C 28 EL C 42 EML 42 EML 1"3/8 Z6 EM 65 EM 1"3/8 Z6 EP 65
			16.2	18.09	16.01	13.63	12.07			
			22.1	18.09	16.01	13.63	12.07			
			28.9	13.84	12.25	10.42	9.23			
			33.6	13.84	12.25	10.42	9.23			
			40.5	10.53	9.31	7.93	7.02			
			48.9	10.53	9.31	7.93	7.02			
			PL 16003	15	2800	57.6	20.77			
62.9	20.77	18.38				15.64	13.84			
75.2	20.77	18.38				15.64	13.84			
82.1	20.77	18.38				15.64	13.84			
94.9	18.09	16.01				13.63	12.07			
109.3	18.09	16.01				13.63	12.07			
118.5	13.84	12.25				10.42	9.23			
124.0	18.09	16.01				13.63	12.07			
129.4	13.84	12.25				10.42	9.23			
144.0	13.84	12.25				10.42	9.23			
155.9	13.84	12.25				10.42	9.23			
188.2	13.84	12.25				10.42	9.23			
195.3	13.84	12.25				10.42	9.23			
209.7	10.53	9.31				7.93	7.02			
226.8	13.84	12.25				10.42	9.23			
235.4	10.53	9.31				7.93	7.02			
274.1	13.84	12.25	10.42	9.23						
330.3	10.53	9.31	7.93	7.02						
PL 16004	11	2800	352.0	20.77	18.38	15.64	13.84	63 71 80 90 100 112 132 160	050 063 075 090	EL C 28 EL C 42 EML 42 EML 1"3/8 Z6
			388.6	20.77	18.38	15.64	13.84			
			421.2	20.77	18.38	15.64	13.84			
			440.9	18.09	16.01	13.63	12.07			
			459.9	20.77	18.38	15.64	13.84			
			507.7	20.77	18.38	15.64	13.84			
			531.4	18.09	16.01	13.63	12.07			
			554.4	20.77	18.38	15.64	13.84			
			576.1	13.84	12.25	10.42	9.23			
			612.0	18.09	16.01	13.63	12.07			
			640.5	18.09	16.01	13.63	12.07			
			724.4	13.84	12.25	10.42	9.23			
			806.4	13.84	12.25	10.42	9.23			
			907.3	13.84	12.25	10.42	9.23			
			1008.9	18.09	16.01	13.63	12.07			
			1093.7	13.84	12.25	10.42	9.23			
			1270.1	13.84	12.25	10.42	9.23			
			1530.9	13.84	12.25	10.42	9.23			
1849.8	13.84	12.25	10.42	9.23						
2229.7	10.53	9.31	7.93	7.02						

	Pt [kW]	n _{1max} [min ⁻¹]	i _{ges}	Mc [kNm]				Giriş- Input - Antrieb - Entrada - Entrée - Entrada	
				n ₂ x h	n ₂ x h	n ₂ x h	n ₂ x h		
				10.000	20.000	50.000	100.000	IEC (B5)	EL - EML EM - EP - ET
PLB 16002	23	2800	12.3	20.77	18.38	15.64	13.84	80 132 90 160 100 180 112	EM 65 EM 1"3/8 Z6 EP 65
			14.8	18.09	16.01	13.63	12.07		
			19.3	13.84	12.25	10.42	9.23		
			23.3	10.53	9.31	7.93	7.02		
			30.5	13.84	12.25	10.42	9.23		
			36.7	10.53	9.31	7.93	7.02		
PLB 16003	15	2800	46.4	20.77	18.38	15.64	13.84	80 90 100 112 132 160	EL C 28 EL C 42 EML 42 EML 1"3/8 Z6 EM 65 EM 1"3/8 Z6 EP 65
			50.7	20.77	18.38	15.64	13.84		
			61.1	18.09	16.01	13.63	12.07		
			76.5	18.09	16.01	13.63	12.07		
			88.8	18.09	16.01	13.63	12.07		
			96.2	18.09	16.01	13.63	12.07		
			116.1	13.84	12.25	10.42	9.23		
			120.6	18.09	16.01	13.63	12.07		
			125.8	13.84	12.25	10.42	9.23		
			140.0	18.09	16.01	13.63	12.07		
			157.5	13.84	12.25	10.42	9.23		
			182.9	13.84	12.25	10.42	9.23		
			221.0	13.84	12.25	10.42	9.23		
			266.4	10.53	9.31	7.93	7.02		
PLB 16004	11	2800	140.1	20.77	18.38	15.64	13.84	80 90 100 112 132 160	EL C 28 EL C 42 EML 42 EML 1"3/8 Z6 EM 65 EM 1"3/8 Z6 EP 65
			168.9	20.77	18.38	15.64	13.84		
			184.4	18.09	16.01	13.63	12.07		
			203.5	18.09	16.01	13.63	12.07		
			230.9	18.09	16.01	13.63	12.07		
			240.9	13.84	12.25	10.42	9.23		
			290.4	18.09	16.01	13.63	12.07		
			301.8	13.84	12.25	10.42	9.23		
			320.6	18.09	16.01	13.63	12.07		
			347.5	13.84	12.25	10.42	9.23		
			379.5	13.84	12.25	10.42	9.23		
			418.9	13.84	12.25	10.42	9.23		
			457.4	13.84	12.25	10.42	9.23		
			510.4	13.84	12.25	10.42	9.23		
			551.9	13.84	12.25	10.42	9.23		
			665.3	13.84	12.25	10.42	9.23		
803.9	13.84	12.25	10.42	9.23					
969.0	10.53	9.31	7.93	7.02					



$$M_{\max} = M_C \times 2$$

(n₂ x h = 20.000)

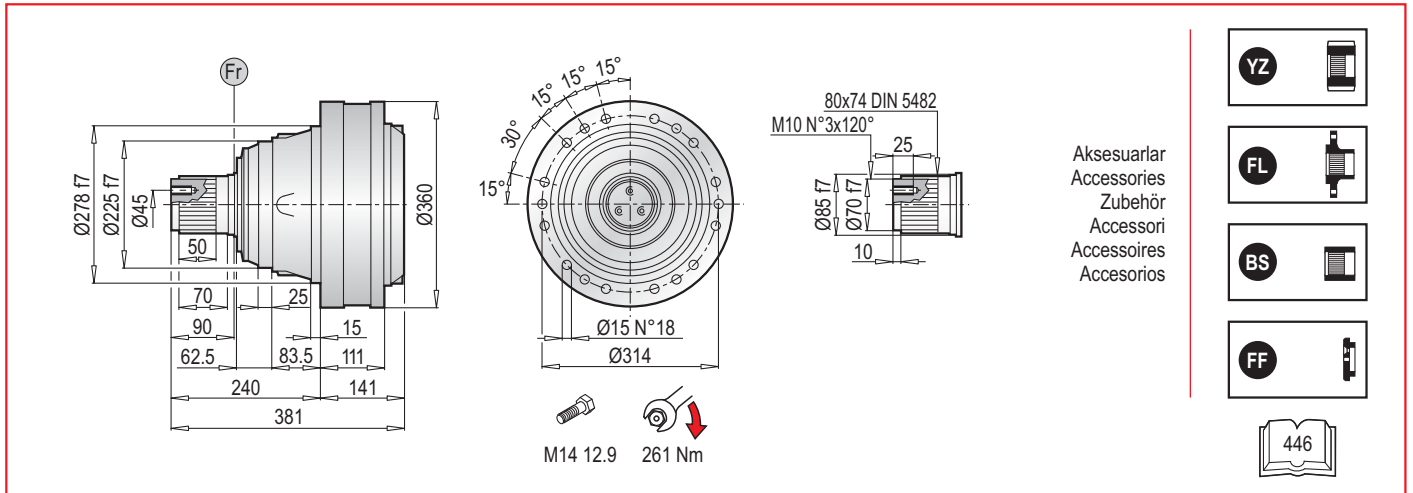

PL 16000 MS - Elektrik Motor Adaptörleri (IEC) / Electric Motor Couplings (IEC) / Anbauvorrichtung Für Elektromotore (IEC) / Predisposizioni Per Motori Elettrici (IEC) / Adaptations Pour Moteurs Electriques (IEC) / Acoplamientos Para Motores Eléctricos (IEC)

PL	IEC 63			IEC 71			IEC 80			IEC 90			IEC 100			IEC 112		
	L _T	Z	ØD	L _T	Z	ØD	L _T	Z	ØD	L _T	Z	ØD	L _T	Z	ØD	L _T	Z	ØD
16001	-	-	-	-	-	-	-	-	-	-	-	-	-	-	-	-	-	-
16002	248.5	-	-	248.5	-	-	268.5	-	-	268.5	-	-	278.5	-	-	278.5	-	-
16003	309.5	36	140	309.5	36	160	329.5	56	200	329.5	56	200	339.5	66	250	339.5	66	250
16004	357.5	-	-	357.5	-	-	377.5	-	-	377.5	-	-	387.5	-	-	387.5	-	-

PL	IEC 132			IEC 160			IEC 180			IEC 200			IEC 225		
	L _T	Z	ØD	L _T	Z	ØD	L _T	Z	ØD	L _T	Z	ØD	L _T	Z	ØD
16001	-	-	-	259	118	350	259	118	350	289	148	400	280	139	450
16002	312.5	-	-	351.5	-	-	351.5	139	350	-	-	-	-	-	-
16003	373.5	100	300	412.5	139	350	-	-	-	-	-	-	-	-	
16004	421.5	-	-	460.5	-	-	-	-	-	-	-	-	-	-	

PL	IEC ~ Kg										
	63	71	80	90	100	112	132	160	180	200	225
16001	-	-	-	-	-	-	-	129	129	139	144
16002	128	128	130	130	131	131	135	145	145	-	-
16003	136	136	138	138	139	139	143	153	-	-	-
16004	142	142	144	144	145	145	149	149	-	-	-

PL 16000 MS - Giriş Milleri / Input Shafts / Antriebswellen / Alberi Entrata / Arbres D'entree / Ejes De Entrada

PL	EL C 28				EL C 42				EML 42				EML 1"3/8 Z6				EM 65				EM 1"3/8 Z6			
	L _T	Z	L	Ød	L _T	Z	L	Ød	L _T	Z	L	Ød	L _T	Z	L	Ød	L _T	Z	L	Ød	L _T	Z	L	Ød
16001	-	-	-	-	-	-	-	-	-	-	-	-	-	-	-	-	262.5	121.5	105	65	262.5	121.5	105	1"3/8
16002	276.5	-	-	-	276.5	-	-	-	306.5	-	-	-	306.5	-	-	-	334	-	-	-	334	-	-	-
16003	337.5	64	50	28	337.5	64	82	42	367.5	94	82	42	367.5	94	106	1"3/8	-	-	-	-	-	-	-	-
16004	385.5	-	-	-	385.5	-	-	-	415.5	-	-	-	415.5	-	-	-	-	-	-	-	-	-	-	-

PL	EP 65				PL	~ Kg						
	L _T	Z	L	Ød		EL C 28	EL C 42	EML 42	EML 1"3/8 Z6	EM 65	EM 1"3/8 Z6	EP 65
16001	294	-	-	-	16001	-	-	-	-	124.0	124.0	133.0
16002	365.5	153	105	65	16002	128.5	129.0	132.0	132.0	140.0	140.0	149.0
16003	-	-	-	-	16003	136.5	137.0	140.0	140.0	-	-	-
16004	-	-	-	-	16004	142.5	143.0	146.0	146.0	-	-	-

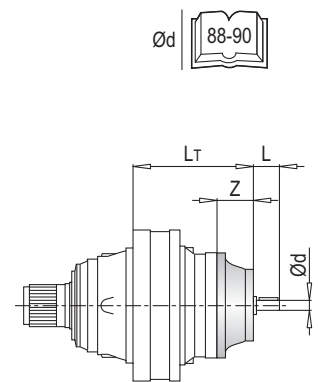
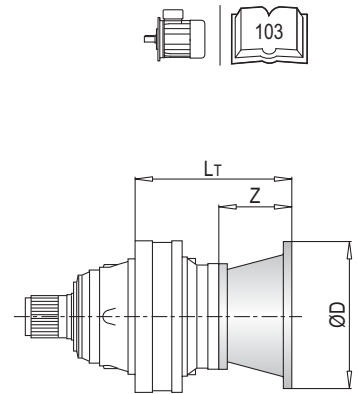

PL 16000 MS - Sonsuz Dişli Redüktör Adaptörleri (PMRV/PRV) / Worm Gearbox Adaptors (PMRV/PRV) / Anschluss Für Schneckengetriebe (PMRV/PRV) / Predisposizioni Per Riduttori A Vite Senza Fine (PMRV/PRV) / Adaptation Pour Reducteurs A Vis Sans Fin (PMRV/PRV) / Acoplamiento Para Reductores De Tornillo Sin Fin (PMRV/PRV)

PL	PMRV/PRV 050					PMRV/PRV 063					PMRV/PRV 075				
	Lm	l	h	MA	G	Lm	l	h	MA	G	Lm	l	h	MA	G
16001	-					-					-				
16002	334					343.5					322.5				
16003	395	50	110	60	80	404.5	63	135	72	95	383.5	75	161	86	112.5
16004	443					452.5					431.5				

PL	PMRV/PRV 090					PMRV/PRV 110					PMRV/PRV 130				
	Lm	l	h	MA	G	Lm	l	h	MA	G	Lm	l	h	MA	G
16001	-					275	110	237.5	127.5	160	280.5	130	277.5	147.5	180
16002	332.5					346.5					352				
16003	393.5	90	193	103	129.5	-					-				
16004	441.5					-					-				

PL	PMRV/PRV ~ Kg					
	050	063	075	090	110	130
16001	-	-	-	-	153	170
16002	131	134.5	137	142	169	186
16003	139	142.5	145	150	-	-
16004	145	148.5	151	156	-	-

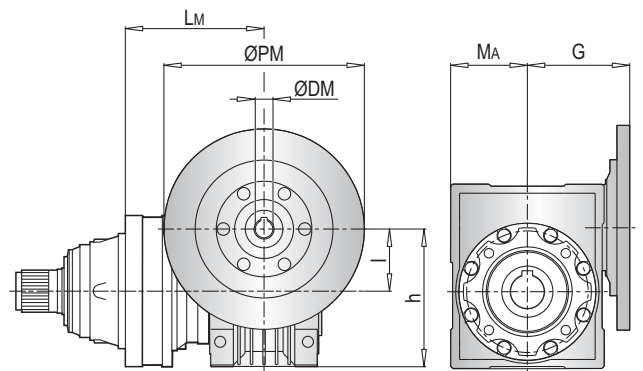

PLB 16000 MS - Elektrik Motor Adaptörleri (IEC) / Electric Motor Couplings (IEC) / Anbauvorrichtung Für Elektromotore (IEC) / Predisposizioni Per Motori Elettrici (IEC) / Adaptations Pour Moteurs Electriques (IEC) / Acoplamientos Para Motores Eléctricos (IEC)

PLB	IEC 63				IEC 71				IEC 80				IEC 90				IEC 100											
	A	Lt	Z	ØD	A	Lt	Z	ØD	A	Lt	Z	ØD	A	Lt	Z	ØD	A	Lt	Z	ØD								
16002	229				229				229				229				229				229							
16003	314		36	140	314		36	160	314		296	56	200	314		56	200	314		66	250							
16004	348.5	196			348.5	196			348.5	216			348.5	216			348.5	226										

PLB	IEC 112				IEC 132				IEC 160				IEC 180			
	A	Lt	Z	ØD	A	Lt	Z	ØD	A	Lt	Z	ØD	A	Lt	Z	ØD
16002	229				229	340			229	379			229	379	139	350
16003	314	306	66	250	314	340	100	300	314	379	139	350	-			
16004	348.5	226			348.5	260			348.5	299			-			

PLB	IEC ~ Kg									
	63	71	80	90	100	112	132	160	180	
16002	149	149	151	151	152	152	156	166	166	
16003	168	168	170	170	171	171	175	185	-	
16004	151	151	153	153	154	154	159	169	-	

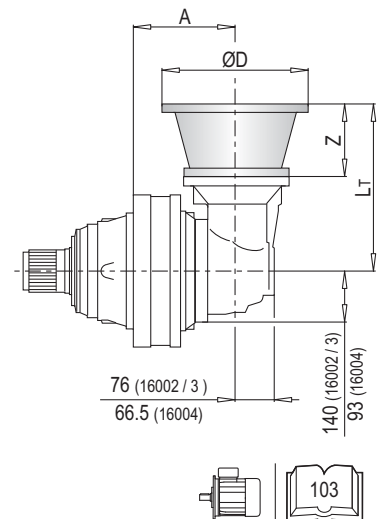

PLB 16000 MS - Giriş Milleri / Input Shafts / Antriebswellen / Alberi Entrata / Arbres D'entree / Ejes De Entrada

PLB	EL C 28					EL C 42					EML 42					EML 1"3/8 Z6					EM 65						
	A	Lt	Z	L	Ød	A	Lt	Z	L	Ød	A	Lt	Z	L	Ød	A	Lt	Z	L	Ød	A	Lt	Z	L	Ød		
16002	229					229					229					229					229						
16003	314		64	50	28	314		64	82	42	314		94	82	42	314		94	106	1"3/8	314	361.5	121.5	105	65		
16004	348.5	224				348.5	224				348.5	254			348.5	254					348.5	281.5					

PLB	EM 1"3/8 Z6					EP 65					PLB	~ Kg						
	A	Lt	Z	L	Ød	A	Lt	Z	L	Ød		EL C 28	EL C 42	EML 42	EML 1"3/8 Z6	EM 65	EM 1"3/8 Z6	EP 65
16002	229					229	393				149.5	150.0	153.0	153.0	161.0	161.0	170.0	
16003	314	361.5	121.5	105	1"3/8	314	393	153	105	65	168.5	169.0	172.0	172.0	180.0	180.0	189.0	
16004	348.5	281.5				348.5	313				151.5	152.0	155.0	155.0	163.0	163.0	172.0	

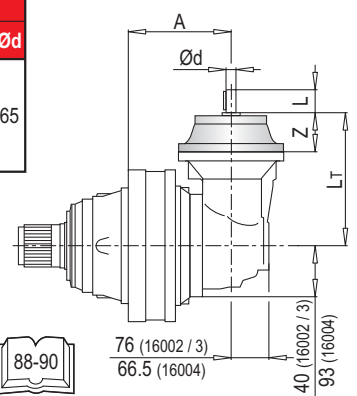

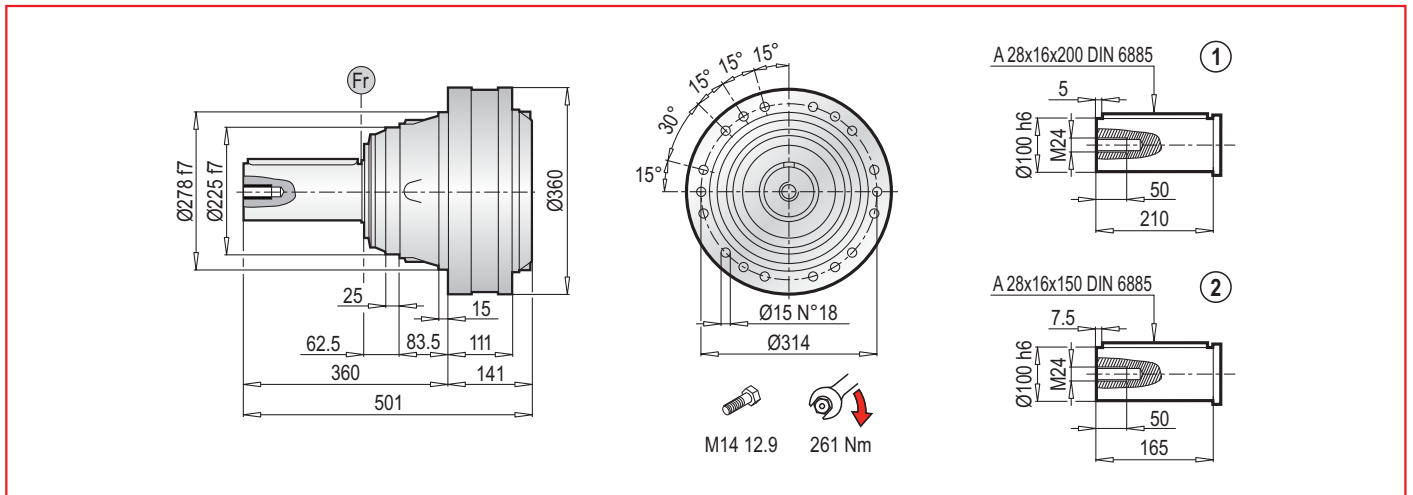

PL 16000 MC - Elektrik Motor Adaptörleri (IEC) / Electric Motor Couplings (IEC) / Anbauvorrichtung Für Elektromotore (IEC) / Predisposizioni Per Motori Elettrici (IEC) / Adaptations Pour Moteurs Electriques (IEC) / Acoplamientos Para Motores Eléctricos (IEC)

PL	IEC 63			IEC 71			IEC 80			IEC 90			IEC 100			IEC 112		
	L _T	Z	ØD	L _T	Z	ØD	L _T	Z	ØD	L _T	Z	ØD	L _T	Z	ØD	L _T	Z	ØD
16001	-	-	-	-	-	-	-	-	-	-	-	-	-	-	-	-	-	-
16002	248.5	-	-	248.5	-	-	268.5	-	-	268.5	-	-	278.5	-	-	278.5	-	-
16003	309.5	36	140	309.5	36	160	329.5	56	200	329.5	56	200	339.5	66	250	339.5	66	250
16004	357.5	-	-	357.5	-	-	377.5	-	-	377.5	-	-	387.5	-	-	387.5	-	-

PL	IEC 132			IEC 160			IEC 180			IEC 200			IEC 225		
	L _T	Z	ØD	L _T	Z	ØD	L _T	Z	ØD	L _T	Z	ØD	L _T	Z	ØD
16001	-	-	-	259	118	350	259	118	350	289	148	400	280	139	450
16002	312.5	-	-	351.5	-	-	351.5	139	350	-	-	-	-	-	-
16003	373.5	100	300	412.5	139	350	-	-	-	-	-	-	-	-	-
16004	421.5	-	-	460.5	-	-	-	-	-	-	-	-	-	-	-

PL	IEC ~ Kg										
	63	71	80	90	100	112	132	160	180	200	225
16001	-	-	-	-	-	-	-	129	129	139	144
16002	128	128	130	130	131	131	135	145	145	-	-
16003	136	136	138	138	139	139	143	153	-	-	-
16004	142	142	144	144	145	145	149	149	-	-	-

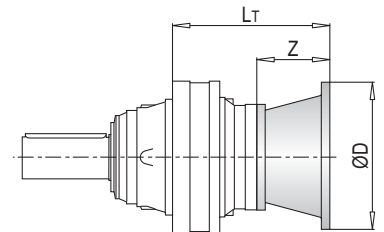

PL 16000 MC - Giriş Milleri / Input Shafts / Antriebswellen / Alberi Entrata / Arbres D'entree / Ejes De Entrada

PL	EL C 28				EL C 42				EML 42				EML 1"3/8 Z6				EM 65				EM 1"3/8 Z6			
	L _T	Z	L	Ød	L _T	Z	L	Ød	L _T	Z	L	Ød	L _T	Z	L	Ød	L _T	Z	L	Ød	L _T	Z	L	Ød
16001	-	-	-	-	-	-	-	-	-	-	-	-	-	-	-	-	262.5	121.5	105	65	262.5	121.5	105	1"3/8
16002	276.5	-	-	-	276.5	-	-	-	306.5	-	-	-	306.5	-	-	-	334	-	-	-	334	-	-	-
16003	337.5	64	50	28	337.5	64	82	42	367.5	94	82	42	367.5	94	106	1"3/8	-	-	-	-	-	-	-	-
16004	385.5	-	-	-	385.5	-	-	-	415.5	-	-	-	415.5	-	-	-	-	-	-	-	-	-	-	-

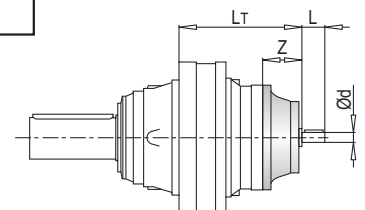

PL	EP 65				PL	~ Kg						
	L _T	Z	L	Ød		EL C 28	EL C 42	EML 42	EML 1"3/8 Z6	EM 65	EM 1"3/8 Z6	EP 65
16001	294	-	-	-	16001	-	-	-	-	124.0	124.0	133.0
16002	365.5	153	105	65	16002	128.5	129.0	132.0	132.0	140.0	140.0	149.0
16003	-	-	-	-	16003	136.5	137.0	140.0	140.0	-	-	-
16004	-	-	-	-	16004	142.5	143.0	146.0	146.0	-	-	-

PL 16000 MC - Sonsuz Dişli Redüktör Adaptörleri (PMRV/PRV) / Worm Gearbox Adaptors (PMRV/PRV) / Anschluss Für Schneckengetriebe (PMRV/PRV) / Predisposizioni Per Riduttori A Vite Senza Fine (PMRV/PRV) / Adaptation Pour Reducteurs A Vis Sans Fin (PMRV/PRV) / Acoplamiento Para Reductores De Tornillo Sin Fin (PMRV/PRV)

PL	PMRV/PRV 050					PMRV/PRV 063					PMRV/PRV 075				
	Lm	l	h	MA	G	Lm	l	h	MA	G	Lm	l	h	MA	G
16001	-					-					-				
16002	334					343.5					322.5				
16003	395	50	110	60	80	404.5	63	135	72	95	383.5	75	161	86	112.5
16004	443					452.5					431.5				

PL	PMRV/PRV 090					PMRV/PRV 110					PMRV/PRV 130				
	Lm	l	h	MA	G	Lm	l	h	MA	G	Lm	l	h	MA	G
16001	-					275	110	237.5	127.5	160	280.5	130	277.5	147.5	180
16002	332.5					346.5					352				
16003	393.5	90	193	103	129.5	-					-				
16004	441.5					-					-				

PL	PMRV/PRV ~ Kg					
	050	063	075	090	110	130
16001	-	-	-	-	153	170
16002	131	134.5	137	142	169	186
16003	139	142.5	145	150	-	-
16004	145	148.5	151	156	-	-

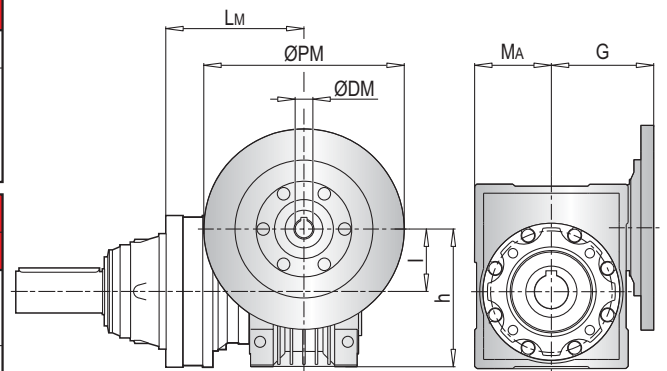

PLB 16000 MC - Elektrik Motor Adaptörleri (IEC) / Electric Motor Couplings (IEC) / Anbauvorrichtung Für Elektromotore (IEC) / Predisposizioni Per Motori Elettrici (IEC) / Adaptations Pour Moteurs Electriques (IEC) / Acoplamientos Para Motores Eléctricos (IEC)

PLB	IEC 80				IEC 90				IEC 100				IEC 112				IEC 132				
	A	Lt	Z	ØD	A	Lt	Z	ØD	A	Lt	Z	ØD	A	Lt	Z	ØD	A	Lt	Z	ØD	
16002	229				229				229				229				229				
16003	314	296	56	200	314	296	56	200	314	306	66	250	314	306	66	250	314	340	100	300	
16004	348.5	216			348.5	216			348.5	226			348.5	226			348.5	260			

PLB	IEC 160				IEC 180			
	A	Lt	Z	ØD	A	Lt	Z	ØD
16002	229				229	379	139	350
16003	314	379	139	350	-			
16004	348.5	299			-			

PLB	IEC ~ Kg						
	80	90	100	112	132	160	180
16002	151	151	152	152	156	166	166
16003	170	170	171	171	175	185	-
16004	153	153	154	154	158	168	-

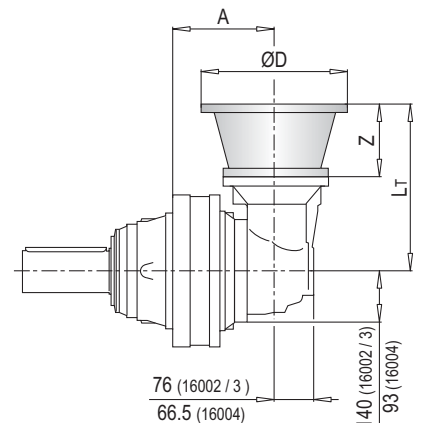

PLB 16000 MC - Giriş Milleri / Input Shafts / Antriebswellen / Alberi Entrada / Arbres D'entree / Ejes De Entrada

PLB	EL C 28					EL C 42					EML 42					EML 1"3/8 Z6					EM 65					
	A	Lt	Z	L	Ød	A	Lt	Z	L	Ød	A	Lt	Z	L	Ød	A	Lt	Z	L	Ød	A	Lt	Z	L	Ød	
16002	229					229					229					229					229					
16003	314	304	64	50	28	314	304	64	82	42	314	334	94	82	42	314	334	94	106	1"3/8	314	361.5	121.5	105	65	
16004	348.5	224				348.5	224				348.5	254				348.5	254				348.5	281.5				

PLB	EM 1"3/8 Z6					EP 65				
	A	Lt	Z	L	Ød	A	Lt	Z	L	Ød
16002	229					229	393	153	105	65
16003	314	361.5	121.5	105	1"3/8	314	393	153	105	65
16004	348.5	281.5				348.5	313			

PLB	~ Kg						
	EL C 28	EL C 42	EML 42	EML 1"3/8 Z6	EM 65	EM 1"3/8 Z6	EP 65
16002	149.5	150.0	153.0	153.0	161.0	161.0	170.0
16003	168.5	169.0	172.0	172.0	180.0	180.0	189.0
16004	151.5	152.0	155.0	155.0	163.0	163.0	172.0

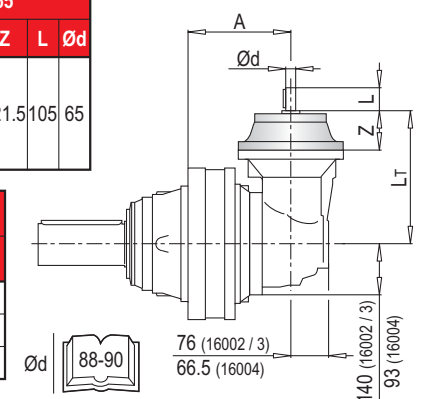

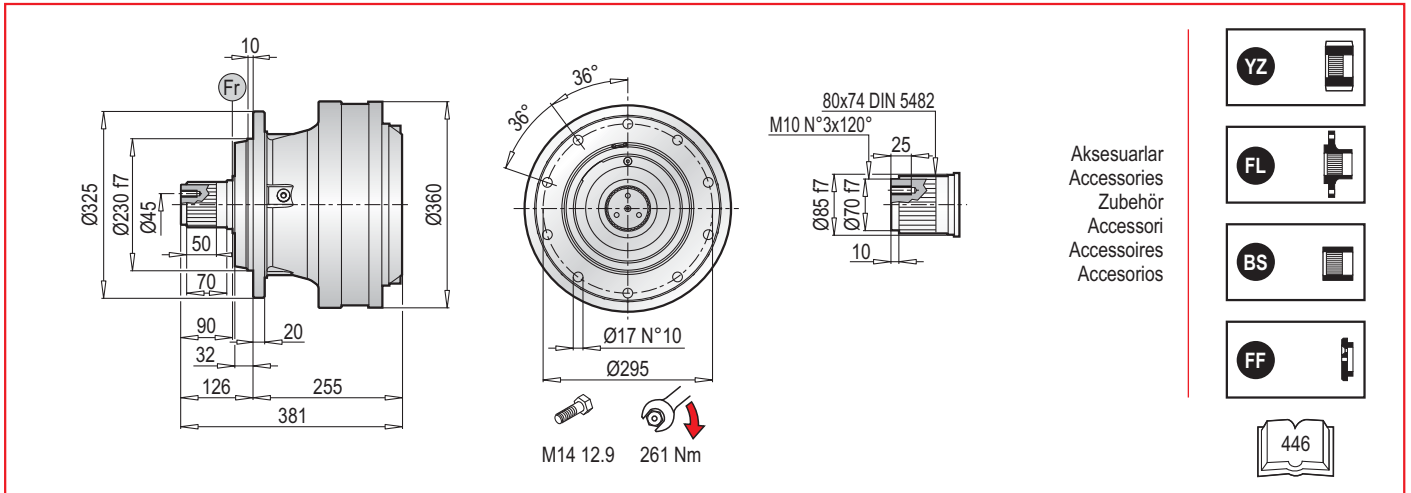

PL 16000 MSF - Elektrik Motor Adaptörleri (IEC) / Electric Motor Couplings (IEC) / Anbauvorrichtung Für Elektromotore (IEC) / Predisposizioni Per Motori Elettrici (IEC) / Adaptations Pour Moteurs Electriques (IEC) / Acoplamientos Para Motores Eléctricos (IEC)

PL	IEC 63			IEC 71			IEC 80			IEC 90			IEC 100			IEC 112		
	L _T	Z	ØD	L _T	Z	ØD	L _T	Z	ØD	L _T	Z	ØD	L _T	Z	ØD	L _T	Z	ØD
16001	-	-	-	-	-	-	-	-	-	-	-	-	-	-	-	-	-	-
16002	362.5	-	-	362.5	-	-	382.5	-	-	382.5	-	-	392.5	-	-	392.5	-	-
16003	423.5	36	140	423.5	36	160	443.5	56	200	443.5	56	200	453.5	66	250	453.5	66	250
16004	471.5	-	-	471.5	-	-	491.5	-	-	491.5	-	-	501.5	-	-	501.5	-	-

PL	IEC 132			IEC 160			IEC 180			IEC 200			IEC 225		
	L _T	Z	ØD	L _T	Z	ØD	L _T	Z	ØD	L _T	Z	ØD	L _T	Z	ØD
16001	-	-	-	373	118	350	373	118	350	403	148	400	394	139	450
16002	426.5	-	-	465.5	-	-	465.5	139	350	-	-	-	-	-	-
16003	487.5	100	300	526.5	139	350	-	-	-	-	-	-	-	-	-
16004	535.5	-	-	574.5	-	-	-	-	-	-	-	-	-	-	-

PL	IEC ~ Kg										
	63	71	80	90	100	112	132	160	180	200	225
16001	-	-	-	-	-	-	-	136	136	146	151
16002	135	135	137	137	138	138	142	152	152	-	-
16003	143	143	145	145	146	146	150	160	-	-	-
16004	149	149	151	151	152	152	156	156	-	-	-

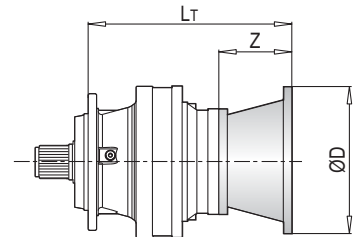

PL 16000 MSF - Giriş Milleri / Input Shafts / Antriebswellen / Alberi Entrata / Arbres D'entree / Ejes De Entrada

PL	EL C 28				EL C 42				EML 42				EML 1"3/8 Z6				EM 65				EM 1"3/8 Z6			
	L _T	Z	L	Ød	L _T	Z	L	Ød	L _T	Z	L	Ød	L _T	Z	L	Ød	L _T	Z	L	Ød	L _T	Z	L	Ød
16001	-	-	-	-	-	-	-	-	-	-	-	-	-	-	-	-	376.5	121.5	105	65	376.5	121.5	105	1"3/8
16002	390.5	-	-	-	390.5	-	-	-	420.5	-	-	-	420.5	-	-	-	461.5	-	-	-	461.5	-	-	-
16003	451.5	64	50	28	451.5	64	82	42	481.5	94	82	42	481.5	94	106	1"3/8	-	-	-	-	-	-	-	-
16004	499.5	-	-	-	499.5	-	-	-	529.5	-	-	-	529.5	-	-	-	-	-	-	-	-	-	-	-

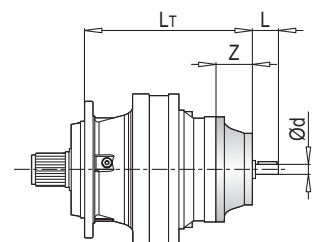

PL	EP 65				PL	~ Kg							
	L _T	Z	L	Ød		EL C 28	EL C 42	EML 42	EML 1"3/8 Z6	EM 65	EM 1"3/8 Z6	EP 65	
16001	408	-	-	-	16001	-	-	-	-	131	131	140	
16002	493	153	105	65	16002	135.5	136	139	139	147	147	156	
16003	-	-	-	-	16003	143.5	144	147	147	-	-	-	
16004	-	-	-	-	16004	149.5	150	153	153	-	-	-	

PL 16000 MSF - Sonsuz Dişli Redüktör Adaptörleri (PMRV/PRV) / Worm Gearbox Adaptors (PMRV/PRV) / Anschluss Für Schneckengetriebe (PMRV/PRV) / Predisposizioni Per Riduttori A Vite Senza Fine (PMRV/PRV) / Adaptation Pour Reducteurs A Vis Sans Fin (PMRV/PRV) / Acoplamiento Para Reductores De Tornillo Sin Fin (PMRV/PRV)

PL	PMRV/PRV 050					PMRV/PRV 063					PMRV/PRV 075				
	Lm	l	h	MA	G	Lm	l	h	MA	G	Lm	l	h	MA	G
16001	-					-					-				
16002	452					461.5					440.5				
16003	513	50	110	60	80	522.5	63	135	72	95	501.5	75	161	86	112.5
16004	561					570.5					549.5				

PL	PMRV/PRV 090					PMRV/PRV 110					PMRV/PRV 130					
	Lm	l	h	MA	G	Lm	l	h	MA	G	Lm	l	h	MA	G	
16001	-					393					400.5					180
16002	450.5					478	110	237.5	127.5	160	485.5	130	277.5	147.5		
16003	511.5	90	193	103	129.5	-					-					
16004	559.5					-					-					

PL	PMRV/PRV ~ Kg					
	050	063	075	090	110	130
16001	-	-	-	-	160	177
16002	138	141.5	144	149	176	193
16003	146	149.5	152	157	-	-
16004	152	155.5	158	163	-	-

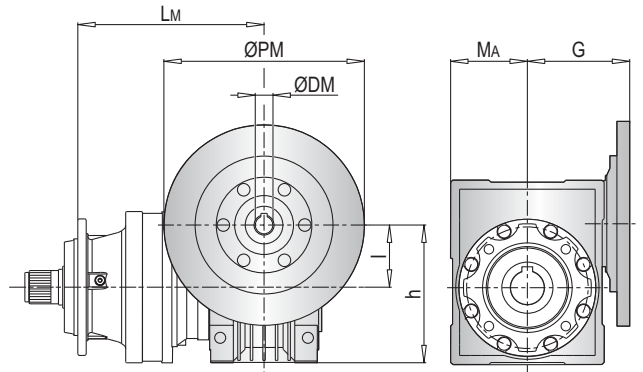

ØPM
ØDM



PLB 16000 MSF - Elektrik Motor Adaptörleri (IEC) / Electric Motor Couplings (IEC) / Anbauvorrichtung Für Elektromotore (IEC) / Predisposizioni Per Motori Elettrici (IEC) / Adaptations Pour Moteurs Electriques (IEC) / Acoplamientos Para Motores Eléctricos (IEC)

PLB	IEC 80				IEC 90				IEC 100				IEC 112				IEC 132				
	A	Lt	Z	ØD	A	Lt	Z	ØD	A	Lt	Z	ØD	A	Lt	Z	ØD	A	Lt	Z	ØD	
16002	343				345				343				343				343				
16003	428	296	56	200	428	296	56	200	428	306	66	250	428	306	66	250	428	340	100	300	
16004	462.5	216			462.5	216			462.5	226			462.5	226			462.5	260			

PLB	IEC 160				IEC 180			
	A	Lt	Z	ØD	A	Lt	Z	ØD
16002	343				343	379	139	350
16003	428	379	139	350	-			
16004	462.5	299			-			

PLB	IEC ~ Kg						
	80	90	100	112	132	160	180
16002	158	158	159	159	163	173	173
16003	177	177	178	178	182	192	-
16004	160	160	161	161	166	166	-

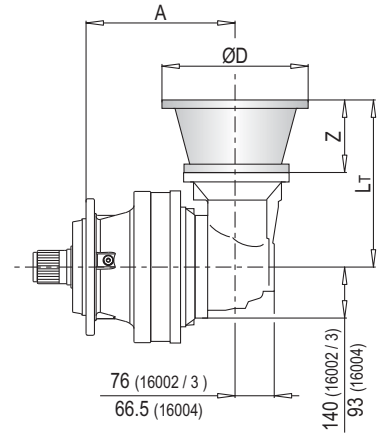

76 (16002 / 3)
66.5 (16004)
140 (16002 / 3)
93 (16004)



PLB 16000 MSF - Giriş Milleri / Input Shafts / Antriebswellen / Alberi Entrata / Arbres D'entree / Ejes De Entrada

PLB	EL C 28					EL C 42					EML 42					EML 1"3/8 Z6					EM 65					
	A	Lt	Z	L	Ød	A	Lt	Z	L	Ød	A	Lt	Z	L	Ød	A	Lt	Z	L	Ød	A	Lt	Z	L	Ød	
16002	343					343					343					343					343					
16003	428	304	64	50	28	428	304	64	82	42	428	334	94	82	42	428	334	94	106	1"3/8	428	377.5	121.5	105	65	
16004	462.5	224				462.5	224				462.5	254				462.5	254				462.5	297.5				

PLB	EM 1"3/8 Z6					EP 65				
	A	Lt	Z	L	Ød	A	Lt	Z	L	Ød
16002	343					343				
16003	428	377.5	121.5	105	1"3/8	428	409	153	105	65
16004	462.5	297.5				462.5	329			

PLB	~ Kg						
	EL C 28	EL C 42	EML 42	EML 1"3/8 Z6	EM 65	EM 1"3/8 Z6	EP 65
16002	156.5	157	160	160	168	168	177
16003	175.5	176	179	179	187	187	196
16004	158.5	159	162	162	170	170	179

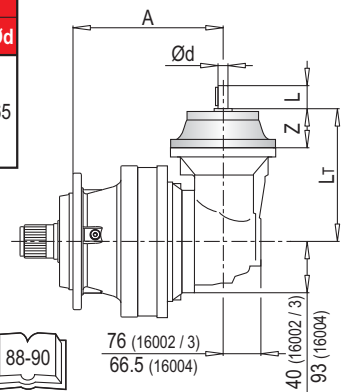

76 (16002 / 3)
66.5 (16004)
140 (16002 / 3)
93 (16004)



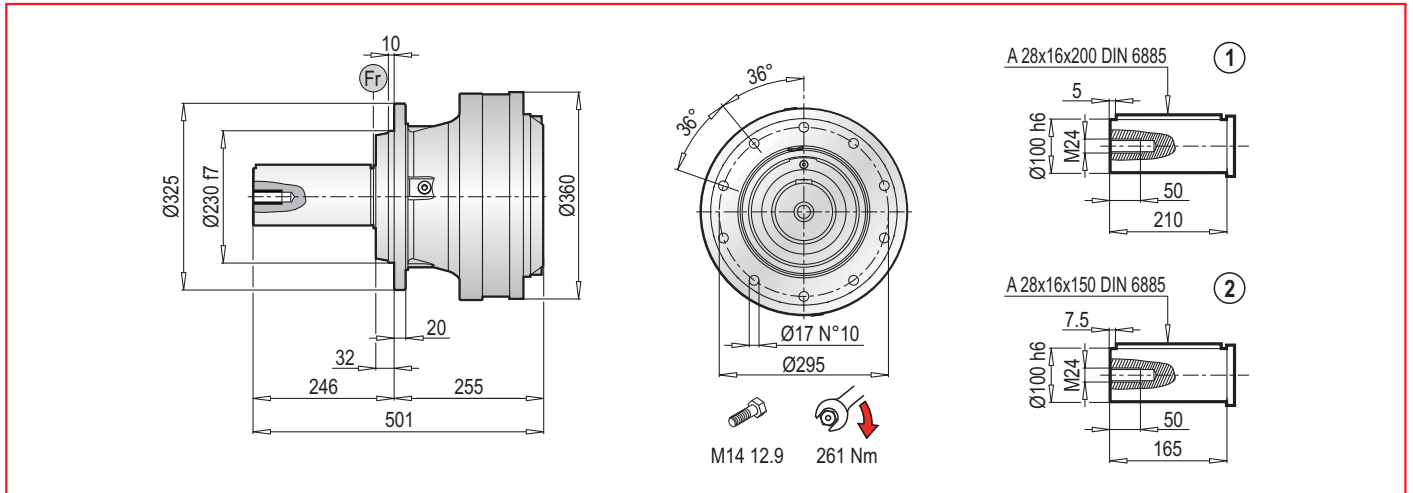

PL 16000 MCF - Elektrik Motor Adaptörleri (IEC) / Electric Motor Couplings (IEC) / Anbauvorrichtung Für Elektromotore (IEC) / Predisposizioni Per Motori Elettrici (IEC) / Adaptations Pour Moteurs Electriques (IEC) / Acoplamientos Para Motores Eléctricos (IEC)

PL	IEC 63			IEC 71			IEC 80			IEC 90			IEC 100			IEC 112		
	L _T	Z	ØD	L _T	Z	ØD	L _T	Z	ØD	L _T	Z	ØD	L _T	Z	ØD	L _T	Z	ØD
16001	-	-	-	-	-	-	-	-	-	-	-	-	-	-	-	-	-	-
16002	362.5	-	-	362.5	-	-	382.5	-	-	382.5	-	-	392.5	-	-	392.5	-	-
16003	423.5	36	140	423.5	36	160	443.5	56	200	443.5	56	200	453.5	66	250	453.5	66	250
16004	471.5	-	-	471.5	-	-	491.5	-	-	491.5	-	-	501.5	-	-	501.5	-	-

PL	IEC 132			IEC 160			IEC 180			IEC 200			IEC 225		
	L _T	Z	ØD	L _T	Z	ØD	L _T	Z	ØD	L _T	Z	ØD	L _T	Z	ØD
16001	-	-	-	373	118	350	373	118	350	403	148	400	394	139	450
16002	426.5	-	-	465.5	-	-	465.5	139	350	-	-	-	-	-	-
16003	487.5	100	300	526.5	139	350	-	-	-	-	-	-	-	-	-
16004	535.5	-	-	574.5	-	-	-	-	-	-	-	-	-	-	-

PL	IEC ~ Kg										
	63	71	80	90	100	112	132	160	180	200	225
16001	-	-	-	-	-	-	-	136	136	146	151
16002	135	135	137	137	138	138	142	152	152	-	-
16003	143	143	145	145	146	146	150	160	-	-	-
16004	149	149	151	151	152	152	156	156	-	-	-

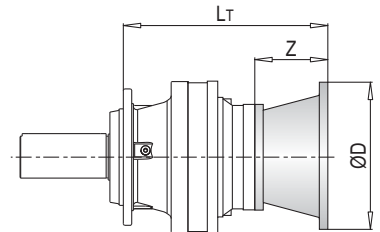
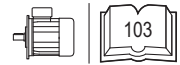

PL 16000 MCF - Giriş Milleri / Input Shafts / Antriebswellen / Alberi Entrata / Arbres D'entree / Ejes De Entrada

PL	EL C 28				EL C 42				EML 42				EML 1"3/8 Z6				EM 65				EM 1"3/8 Z6			
	L _T	Z	L	Ød	L _T	Z	L	Ød	L _T	Z	L	Ød	L _T	Z	L	Ød	L _T	Z	L	Ød	L _T	Z	L	Ød
16001	-	-	-	-	-	-	-	-	-	-	-	-	-	-	-	-	376.5	121.5	105	65	376.5	121.5	105	1"3/8
16002	390.5	-	-	-	390.5	-	-	-	420.5	-	-	-	420.5	-	-	-	461.5	-	-	-	461.5	-	-	-
16003	451.5	64	50	28	451.5	64	82	42	481.5	94	82	42	481.5	94	106	1"3/8	-	-	-	-	-	-	-	-
16004	499.5	-	-	-	499.5	-	-	-	529.5	-	-	-	529.5	-	-	-	-	-	-	-	-	-	-	-

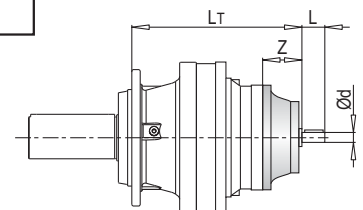

PL	EP 65				PL	~ Kg							
	L _T	Z	L	Ød		EL C 28	EL C 42	EML 42	EML 1"3/8 Z6	EM 65	EM 1"3/8 Z6	EP 65	
16001	408	-	-	-	16001	-	-	-	-	131	131	140	
16002	493	153	105	65	16002	135.5	136	139	139	147	147	156	
16003	-	-	-	-	16003	143.5	144	147	147	-	-	-	
16004	-	-	-	-	16004	149.5	150	153	153	-	-	-	

PL 16000 MCF - Sonsuz Dişlili Redüktör Adaptörleri (PMRV/PRV) / Worm Gearbox Adaptors (PMRV/PRV) / Anschluss Für Schneckengetriebe (PMRV/PRV) / Predisposizioni Per Riduttori A Vite Senza Fine (PMRV/PRV) / Adaptation Pour Reducteurs A Vis Sans Fin (PMRV/PRV) / Acoplamiento Para Reductores De Tornillo Sin Fin (PMRV/PRV)

PL	PMRV/PRV 050					PMRV/PRV 063					PMRV/PRV 075				
	Lm	I	h	MA	G	Lm	I	h	MA	G	Lm	I	h	MA	G
16001	-					-					-				
16002	452					461.5					440.5				
16003	513	50	110	60	80	522.5	63	135	72	95	501.5	75	161	86	112.5
16004	561					570.5					549.5				

PL	PMRV/PRV 090					PMRV/PRV 110					PMRV/PRV 130					
	Lm	I	h	MA	G	Lm	I	h	MA	G	Lm	I	h	MA	G	
16001	-					393					400.5					180
16002	450.5					478	110	237.5	127.5	160	485.5	130	277.5	147.5		
16003	511.5	90	193	103	129.5	-					-					
16004	559.5					-					-					

PL	PMRV/PRV ~ Kg					
	050	063	075	090	110	130
16001	-	-	-	-	160	177
16002	138	141.5	144	149	176	193
16003	146	149.5	152	157	-	-
16004	152	155.5	158	163	-	-

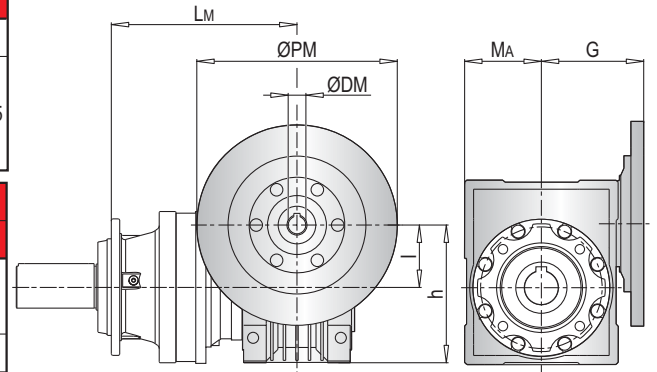

ØPM
ØDM



PLB 16000 MCF - Elektrik Motor Adaptörleri (IEC) / Electric Motor Couplings (IEC) / Anbauvorrichtung Für Elektromotore (IEC) / Predisposizioni Per Motori Elettrici (IEC) / Adaptations Pour Moteurs Electriques (IEC) / Acoplamientos Para Motores Eléctricos (IEC)

PLB	IEC 80				IEC 90				IEC 100				IEC 112				IEC 132				
	A	Lt	Z	ØD	A	Lt	Z	ØD	A	Lt	Z	ØD	A	Lt	Z	ØD	A	Lt	Z	ØD	
16002	343				345				343				343				343				
16003	428	296	56	200	428	296	56	200	428	306	66	250	428	306	66	250	428	340	100	300	
16004	462.5	216			462.5	216			462.5	226			462.5	226			462.5	260			

PLB	IEC 160				IEC 180			
	A	Lt	Z	ØD	A	Lt	Z	ØD
16002	343				343	379	139	350
16003	428	379	139	350	-			
16004	462.5	299			-			

PLB	IEC ~ Kg						
	80	90	100	112	132	160	180
16002	158	158	159	159	163	173	173
16003	177	177	178	178	182	192	-
16004	160	160	161	161	166	166	-

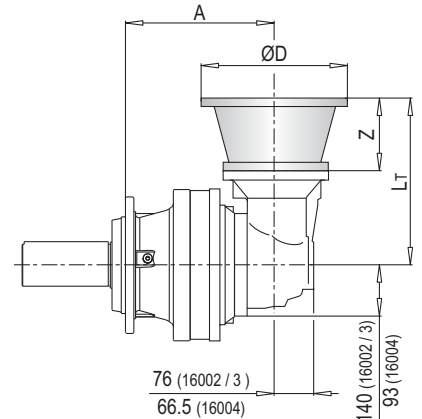

76 (16002 / 3)
66.5 (16004)
140 (16002 / 3)
93 (16004)



PLB 16000 MCF - Giriş Milleri / Input Shafts / Antriebswellen / Alberi Entrata / Arbres D'entree / Ejes De Entrada

PLB	EL C 28					EL C 42					EML 42					EML 1"3/8 Z6					EM 65					
	A	Lt	Z	L	Ød	A	Lt	Z	L	Ød	A	Lt	Z	L	Ød	A	Lt	Z	L	Ød	A	Lt	Z	L	Ød	
16002	343					343					343					343					343					
16003	428	304	64	50	28	428	304	64	82	42	428	334	94	82	42	428	334	94	106	1"3/8	428	377.5	121.5	105	65	
16004	462.5	224				462.5	224				462.5	254				462.5	254				462.5	297.5				

PLB	EM 1"3/8 Z6					EP 65				
	A	Lt	Z	L	Ød	A	Lt	Z	L	Ød
16002	343					343				
16003	428	377.5	121.5	105	1"3/8	428	409	153	105	65
16004	462.5	297.5				462.5	329			

PLB	~ Kg						
	EL C 28	EL C 42	EML 42	EML 1"3/8 Z6	EM 65	EM 1"3/8 Z6	EP 65
16002	156.5	157	160	160	168	168	177
16003	175.5	176	179	179	187	187	196
16004	158.5	159	162	162	170	170	179

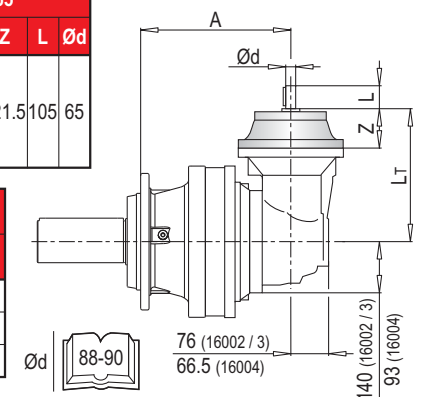

Ød
76 (16002 / 3)
66.5 (16004)
140 (16002 / 3)
93 (16004)

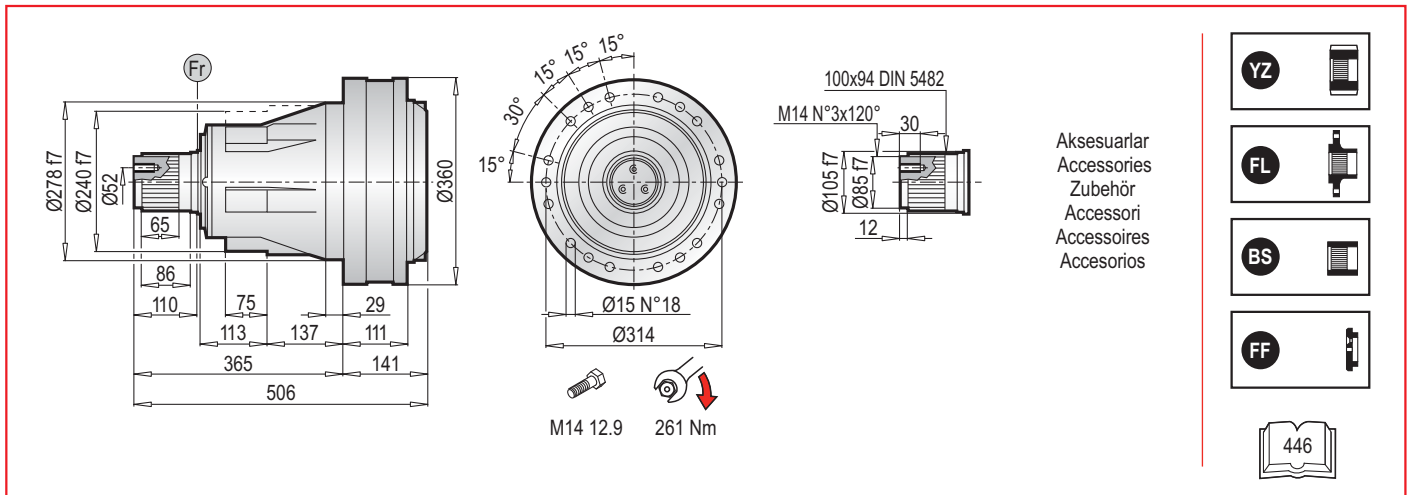

PL 16000 PS - Elektrik Motor Adaptörleri (IEC) / Electric Motor Couplings (IEC) / Anbauvorrichtung Für Elektromotore (IEC) / Predisposizioni Per Motori Elettrici (IEC) / Adaptations Pour Moteurs Electriques (IEC) / Acoplamientos Para Motores Eléctricos (IEC)

PL	IEC 63			IEC 71			IEC 80			IEC 90			IEC 100			IEC 112		
	L _T	Z	ØD	L _T	Z	ØD	L _T	Z	ØD	L _T	Z	ØD	L _T	Z	ØD	L _T	Z	ØD
16001	-	-	-	-	-	-	-	-	-	-	-	-	-	-	-	-	-	-
16002	248.5	-	-	248.5	-	-	268.5	-	-	268.5	-	-	278.5	-	-	278.5	-	-
16003	309.5	36	140	309.5	36	160	329.5	56	200	329.5	56	200	339.5	66	250	339.5	66	250
16004	357.5	-	-	357.5	-	-	377.5	-	-	377.5	-	-	387.5	-	-	387.5	-	-

PL	IEC 132			IEC 160			IEC 180			IEC 200			IEC 225		
	L _T	Z	ØD	L _T	Z	ØD	L _T	Z	ØD	L _T	Z	ØD	L _T	Z	ØD
16001	-	-	-	259	118	350	259	118	350	289	148	400	280	139	450
16002	312.5	-	-	351.5	-	-	351.5	139	350	-	-	-	-	-	-
16003	373.5	100	300	412.5	139	350	-	-	-	-	-	-	-	-	-
16004	421.5	-	-	460.5	-	-	-	-	-	-	-	-	-	-	-

PL	IEC ~ Kg										
	63	71	80	90	100	112	132	160	180	200	225
16001	-	-	-	-	-	-	-	156	156	166	171
16002	155	155	157	157	158	158	162	172	172	-	-
16003	163	163	165	165	166	166	170	180	-	-	-
16004	169	169	171	171	172	172	176	186	-	-	-

PL 16000 PS - Giriş Milleri / Input Shafts / Antriebswellen / Alberi Entrata / Arbres D'entree / Ejes De Entrada

PL	EL C 28				EL C 42				EML 42				EML 1"3/8 Z6				EM 65				EM 1"3/8 Z6			
	L _T	Z	L	Ød	L _T	Z	L	Ød	L _T	Z	L	Ød	L _T	Z	L	Ød	L _T	Z	L	Ød	L _T	Z	L	Ød
16001	-	-	-	-	-	-	-	-	-	-	-	-	-	-	-	-	262.5	121.5	105	65	262.5	121.5	105	1"3/8
16002	276.5	-	-	-	276.5	-	-	-	306.5	-	-	-	306.5	-	-	-	334	-	-	-	334	-	-	-
16003	337.5	64	50	28	337.5	64	82	42	367.5	94	82	42	367.5	94	106	1"3/8	-	-	-	-	-	-	-	-
16004	385.5	-	-	-	385.5	-	-	-	415.5	-	-	-	415.5	-	-	-	-	-	-	-	-	-	-	-

PL	EP 65				PL	~ Kg						
	L _T	Z	L	Ød		EL C 28	EL C 42	EML 42	EML 1"3/8 Z6	EM 65	EM 1"3/8 Z6	EP 65
16001	294	-	-	-	16001	-	-	-	-	151.0	151.0	160.0
16002	365.5	153	105	65	16002	155.5	156.0	159.0	159.0	167.0	167.0	176.0
16003	-	-	-	-	16003	163.5	164.0	167.0	167.0	-	-	-
16004	-	-	-	-	16004	169.5	170.0	173.0	173.0	-	-	-

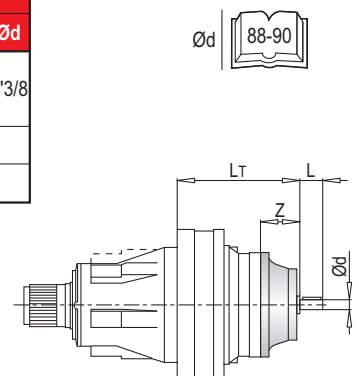
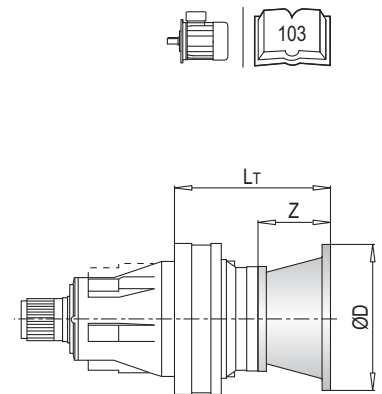

PL 16000 PS - Sonsuz Dişli Redüktör Adaptörleri (PMRV/PRV) / Worm Gearbox Adaptors (PMRV/PRV) / Anschluss Für Schneckengetriebe (PMRV/PRV) / Predisposizioni Per Riduttori A Vite Senza Fine (PMRV/PRV) / Adaptation Pour Reducteurs A Vis Sans Fin (PMRV/PRV) / Acoplamiento Para Reductores De Tornillo Sin Fin (PMRV/PRV)

PL	PMRV/PRV 050					PMRV/PRV 063					PMRV/PRV 075				
	Lm	I	h	MA	G	Lm	I	h	MA	G	Lm	I	h	MA	G
16001	-					-					-				
16002	338					347.5					326.5				
16003	399	50	110	60	80	408.5	63	135	72	95	387.5	75	161	86	112.5
16004	447					456.5					435.5				

PL	PMRV/PRV 090					PMRV/PRV 110					PMRV/PRV 130					
	Lm	I	h	MA	G	Lm	I	h	MA	G	Lm	I	h	MA	G	
16001	-					279					286.5					
16002	336.5					364	110	237.5	127.5	160	371.5	130	277.5	147.5	180	
16003	397.5	90	193	103	129.5	-					-					
16004	445.5					-					-					

PL	PMRV/PRV ~ Kg					
	050	063	075	090	110	130
16001	-	-	-	-	180	197
16002	158	161.5	164	169	196	213
16003	166	169.5	172	177	-	-
16004	172	175.5	178	183	-	-

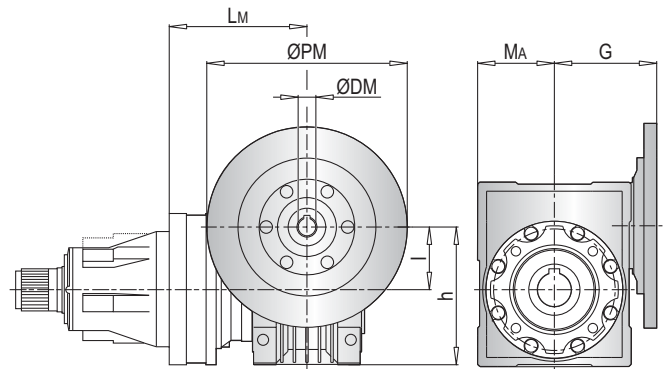

PLB 16000 PS - Elektrik Motor Adaptörleri (IEC) / Electric Motor Couplings (IEC) / Anbauvorrichtung Für Elektromotore (IEC) / Predisposizioni Per Motori Elettrici (IEC) / Adaptations Pour Moteurs Electriques (IEC) / Acoplamientos Para Motores Eléctricos (IEC)

PLB	IEC 80				IEC 90				IEC 100				IEC 112				IEC 132				
	A	Lt	Z	ØD	A	Lt	Z	ØD	A	Lt	Z	ØD	A	Lt	Z	ØD	A	Lt	Z	ØD	
16002	229				229				229				229				229				
16003	314	296	56	200	314	296	56	200	314	306	66	250	314	306	66	250	314	340	100	300	
16004	348.5	216			348.5	216			348.5	226			348.5	226			348.5	260			

PLB	IEC 160				IEC 180			
	A	Lt	Z	ØD	A	Lt	Z	ØD
16002	229				229	379	139	350
16003	314	379	139	350	-			
16004	348.5	299			-			

PLB	IEC ~ Kg						
	80	90	100	112	132	160	180
16002	178	178	179	179	183	193	193
16003	197	197	198	198	202	212	-
16004	180	180	181	181	185	195	-

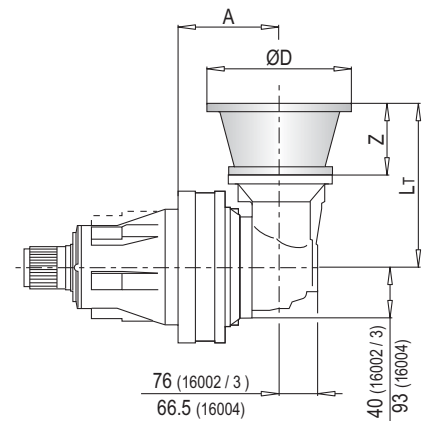

PLB 16000 PS - Giriş Milleri / Input Shafts / Antriebswellen / Alberi Entrata / Arbres D'entree / Ejes De Entrada

PLB	EL C 28					EL C 42					EML 42					EML 1"3/8 Z6					EM 65					
	A	Lt	Z	L	Ød	A	Lt	Z	L	Ød	A	Lt	Z	L	Ød	A	Lt	Z	L	Ød	A	Lt	Z	L	Ød	
16002	229					229					229					229					229					
16003	314	304	64	50	28	314	304	64	82	42	314	334	94	82	42	314	334	94	106	1"3/8	314	377.5	121.5	105	65	
16004	348.5	224				348.5	224				348.5	254				348.5	254				348.5	297.5				

PLB	EM 1"3/8 Z6					EP 65					PLB	~ Kg						
	A	Lt	Z	L	Ød	A	Lt	Z	L	Ød		EL C 28	EL C 42	EML 42	EML 1"3/8 Z6	EM 65	EM 1"3/8 Z6	EP 65
16002	229					229	409	153	105	65	16002	176.5	177.0	180.0	180.0	188.0	188.0	197.0
16003	314	377.5	121.5	105	1"3/8	314	409	153	105	65	16003	195.5	196.0	199.0	199.0	207.0	207.0	216.0
16004	348.5	297.5				348.5	329				16004	178.5	179.0	182.0	182.0	190.0	190.0	199.0

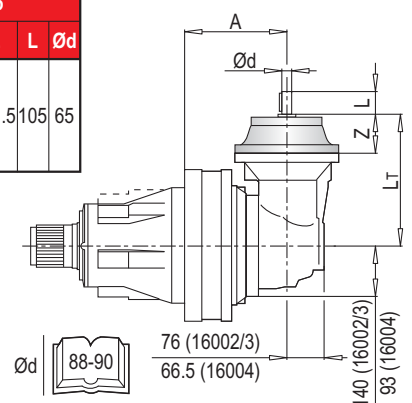

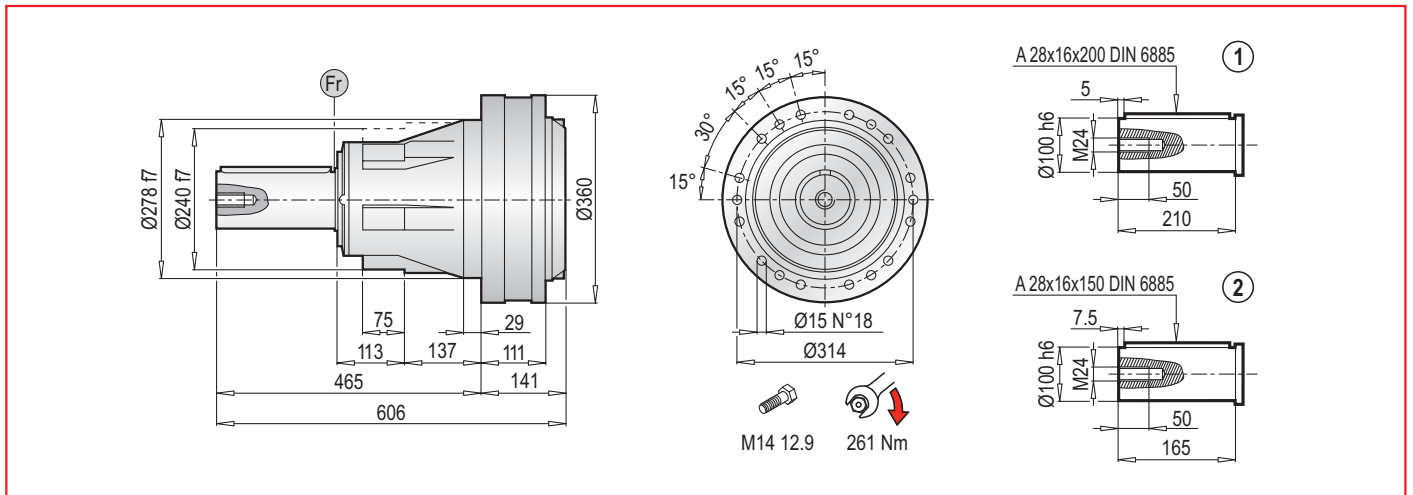

PL 16000 PC - Elektrik Motor Adaptörleri (IEC) / Electric Motor Couplings (IEC) / Anbauvorrichtung Für Elektromotore (IEC) / Predisposizioni Per Motori Elettrici (IEC) / Adaptations Pour Moteurs Electriques (IEC) / Acoplamientos Para Motores Eléctricos (IEC)

PL	IEC 63			IEC 71			IEC 80			IEC 90			IEC 100			IEC 112		
	L _T	Z	ØD	L _T	Z	ØD	L _T	Z	ØD	L _T	Z	ØD	L _T	Z	ØD	L _T	Z	ØD
16001	-	-	-	-	-	-	-	-	-	-	-	-	-	-	-	-	-	-
16002	248.5	-	-	248.5	-	-	268.5	-	-	268.5	-	-	278.5	-	-	278.5	-	-
16003	309.5	36	140	309.5	36	160	329.5	56	200	329.5	56	200	339.5	66	250	339.5	66	250
16004	357.5	-	-	357.5	-	-	377.5	-	-	377.5	-	-	387.5	-	-	387.5	-	-

PL	IEC 132			IEC 160			IEC 180			IEC 200			IEC 225		
	L _T	Z	ØD	L _T	Z	ØD	L _T	Z	ØD	L _T	Z	ØD	L _T	Z	ØD
16001	-	-	-	259	118	350	259	118	350	289	148	400	289	148	450
16002	312.5	-	-	351.5	-	-	351.5	139	350	-	-	-	-	-	-
16003	373.5	100	300	412.5	139	350	-	-	-	-	-	-	-	-	-
16004	421.5	-	-	460.5	-	-	-	-	-	-	-	-	-	-	-

PL	IEC ~ Kg										
	63	71	80	90	100	112	132	160	180	200	225
16001	-	-	-	-	-	-	-	156	156	166	171
16002	155	155	157	157	158	158	162	172	172	-	-
16003	163	163	165	165	166	166	170	180	-	-	-
16004	169	169	171	171	172	172	176	186	-	-	-

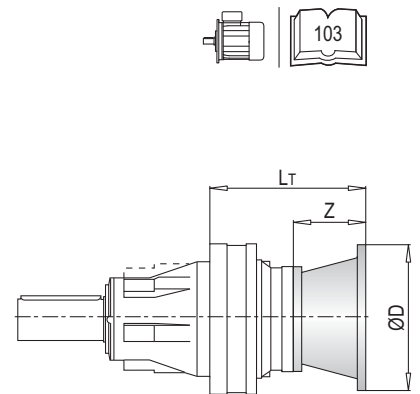

PL 16000 PC - Giriş Milleri / Input Shafts / Antriebswellen / Alberi Entrata / Arbres D'entree / Ejes De Entrada

PL	EL C 28				EL C 42				EML 42				EML 1"3/8 Z6				EM 65				EM 1"3/8 Z6			
	L _T	Z	L	Ød	L _T	Z	L	Ød	L _T	Z	L	Ød	L _T	Z	L	Ød	L _T	Z	L	Ød	L _T	Z	L	Ød
16001	-	-	-	-	-	-	-	-	-	-	-	-	-	-	-	-	262.5	121.5	105	65	262.5	121.5	105	1"3/8
16002	276.5	-	-	-	276.5	-	-	-	306.5	-	-	-	306.5	-	-	-	347.5	-	-	-	347.5	-	-	-
16003	337.5	64	50	28	337.5	64	82	42	367.5	94	82	42	367.5	94	106	1"3/8	-	-	-	-	-	-	-	-
16004	385.5	-	-	-	385.5	-	-	-	415.5	-	-	-	415.5	-	-	-	-	-	-	-	-	-	-	-

PL	EP 65				PL	~ Kg						
	L _T	Z	L	Ød		EL C 28	EL C 42	EML 42	EML 1"3/8 Z6	EM 65	EM 1"3/8 Z6	EP 65
16001	294	-	-	-	16001	-	-	-	-	151.0	151.0	160.0
16002	379	153	105	65	16002	155.5	156.0	159.0	159.0	167.0	167.0	176.0
16003	-	-	-	-	16003	163.5	164.0	167.0	167.0	-	-	-
16004	-	-	-	-	16004	169.5	170.0	173.0	173.0	-	-	-

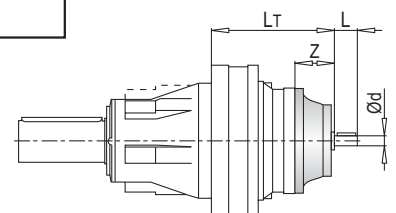

PL 16000 PC - Sansuz Dişli Redüktör Adaptörleri (PMRV/PRV) / Worm Gearbox Adaptors (PMRV/PRV) / Anschluss Für Schneckengetriebe (PMRV/PRV) / Predisposizioni Per Riduttori A Vite Senza Fine (PMRV/PRV) / Adaptation Pour Reducteurs A Vis Sans Fin (PMRV/PRV) / Acoplamiento Para Reductores De Tornillo Sin Fin (PMRV/PRV)

PL	PMRV/PRV 050					PMRV/PRV 063					PMRV/PRV 075				
	Lm	I	h	MA	G	Lm	I	h	MA	G	Lm	I	h	MA	G
16001	-					-					-				
16002	338					347.5					326.5				
16003	399	50	110	60	80	408.5	63	135	72	95	387.5	75	161	86	112.5
16004	447					456.5					435.5				

PL	PMRV/PRV 090					PMRV/PRV 110					PMRV/PRV 130					
	Lm	I	h	MA	G	Lm	I	h	MA	G	Lm	I	h	MA	G	
16001	-					279					286.5					
16002	336.5					350.5	110	237.5	127.5	160	358	130	277.5	147.5	180	
16003	397.5	90	193	103	129.5	-					-					
16004	445.5					-					-					

PL	PMRV/PRV ~ Kg					
	050	063	075	090	110	130
16001	-	-	-	-	180	197
16002	158	161.5	164	169	196	213
16003	166	169.5	172	177	-	-
16004	172	175.5	178	183	-	-

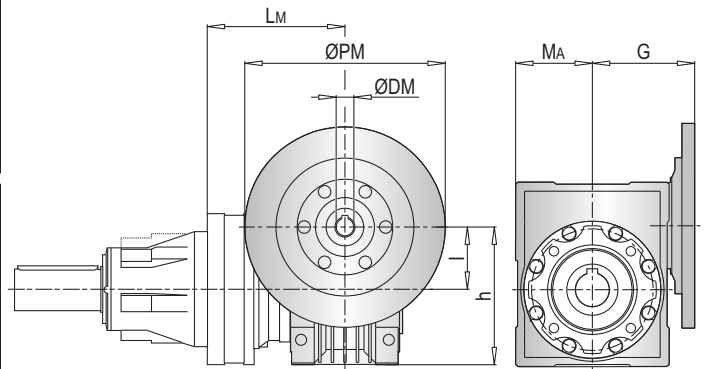

PLB 16000 PC - Elektrik Motor Adaptörleri (IEC) / Electric Motor Couplings (IEC) / Anbauvorrichtung Für Elektromotore (IEC) / Predisposizioni Per Motori Elettrici (IEC) / Adaptations Pour Moteurs Electriques (IEC) / Acoplamientos Para Motores Eléctricos (IEC)

PLB	IEC 80				IEC 90				IEC 100				IEC 112				IEC 132				
	A	Lt	Z	ØD	A	Lt	Z	ØD	A	Lt	Z	ØD	A	Lt	Z	ØD	A	Lt	Z	ØD	
16002	229				229				229				229				229				
16003	314	296	56	200	314	296	56	200	314	306	66	250	314	306	66	250	314	340	100	300	
16004	348.5	216			348.5	216			348.5	226			348.5	226			348.5	260			

PLB	IEC 160				IEC 180			
	A	Lt	Z	ØD	A	Lt	Z	ØD
16002	229				229	379	139	350
16003	314	379	139	350	-			
16004	348.5	299			-			

PLB	IEC ~ Kg							
	80	90	100	112	132	160	180	
16002	178	178	179	179	183	193	193	
16003	197	197	198	198	202	212	-	
16004	180	180	181	181	185	195	-	

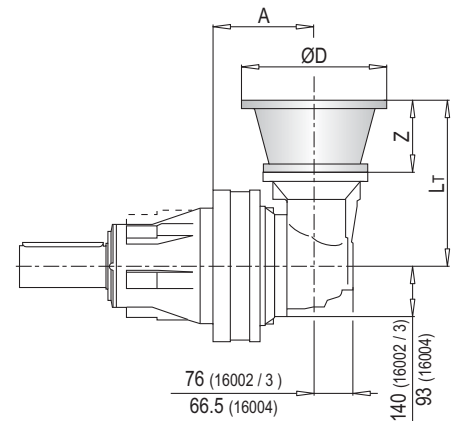

PLB 16000 PC - Giriş Milleri / Input Shafts / Antriebswellen / Alberi Entrata / Arbres D'entree / Ejes De Entrada

PLB	EL C 28					EL C 42					EML 42					EML 1"3/8 Z6					EM 65					
	A	Lt	Z	L	Ød	A	Lt	Z	L	Ød	A	Lt	Z	L	Ød	A	Lt	Z	L	Ød	A	Lt	Z	L	Ød	
16002	229					229					229					229					229					
16003	314	304	64	50	28	314	304	64	82	42	314	334	94	82	42	314	334	94	106	1"3/8	314	377.5	121.5	105	65	
16004	348.5	224				348.5	224				348.5	254				348.5	254				348.5	297.5				

PLB	EM 1"3/8 Z6					EP 65					PLB	~ Kg						
	A	Lt	Z	L	Ød	A	Lt	Z	L	Ød		EL C 28	EL C 42	EML 42	EML 1"3/8 Z6	EM 65	EM 1"3/8 Z6	EP 65
16002	229					229					176.5	177.0	180.0	180.0	188.0	188.0	197.0	
16003	314	377.5	121.5	105	1"3/8	314	409	153	105	65	195.5	196.0	199.0	199.0	207.0	207.0	216.0	
16004	348.5	297.5				348.5	329				178.5	179.0	182.0	182.0	190.0	190.0	199.0	

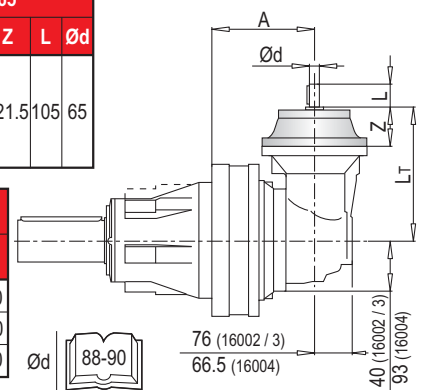

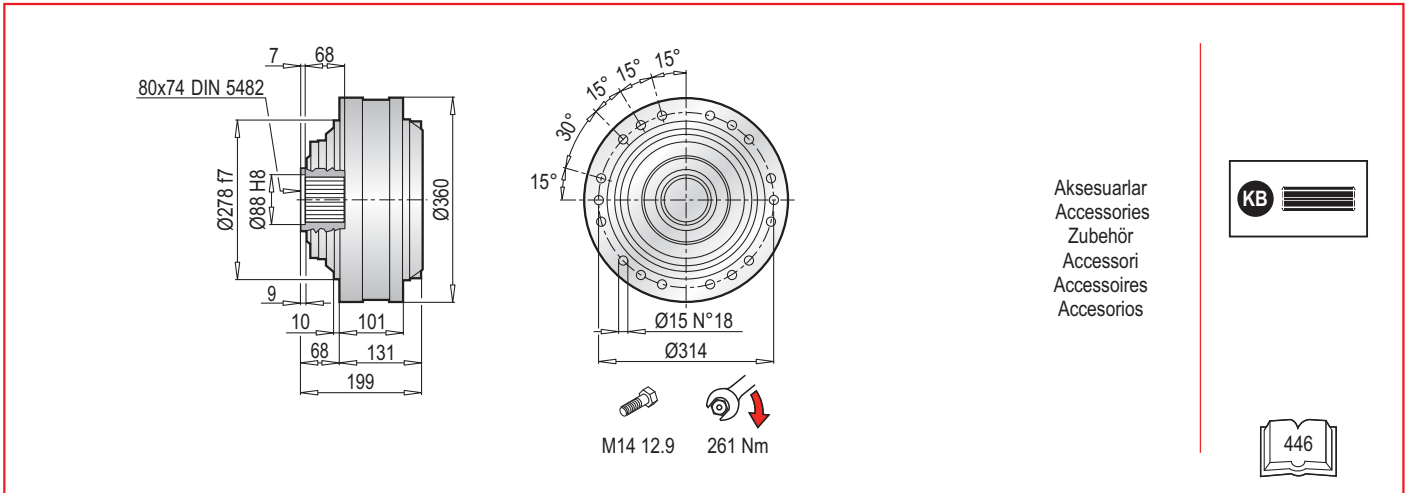

PL 16000 F - Elektrik Motor Adaptörleri (IEC) / Electric Motor Couplings (IEC) / Anbauvorrichtung Für Elektromotore (IEC) / Predisposizioni Per Motori Elettrici (IEC) / Adaptations Pour Moteurs Electriques (IEC) / Acoplamientos Para Motores Eléctricos (IEC)

PL	IEC 63			IEC 71			IEC 80			IEC 90			IEC 100			IEC 112		
	L _T	Z	ØD	L _T	Z	ØD	L _T	Z	ØD	L _T	Z	ØD	L _T	Z	ØD	L _T	Z	ØD
16001	-	-	-	-	-	-	-	-	-	-	-	-	-	-	-	-	-	-
16002	238.5	-	-	238.5	-	-	258.5	-	-	258.5	56	200	268.5	-	-	268.5	-	-
16003	299.5	36	140	299.5	36	160	319.5	56	200	319.5	56	200	329.5	66	250	329.5	66	250
16004	347.5	-	-	347.5	-	-	367.5	-	-	367.5	-	-	377.5	-	-	377.5	-	-

PL	IEC 132			IEC 160			IEC 180			IEC 200			IEC 225		
	L _T	Z	ØD	L _T	Z	ØD	L _T	Z	ØD	L _T	Z	ØD	L _T	Z	ØD
16001	-	-	-	249	118	350	249	118	350	279	148	400	279	148	450
16002	302.5	-	-	341.5	-	-	341.5	139	350	-	-	-	-	-	-
16003	363.5	100	300	402.5	139	350	-	-	-	-	-	-	-	-	
16004	411.5	-	-	450.5	-	-	-	-	-	-	-	-	-	-	

PL	IEC ~ Kg										
	63	71	80	90	100	112	132	160	180	200	225
16001	-	-	-	-	-	-	-	97	97	107	112
16002	96	96	98	98	99	99	103	113	113	-	-
16003	104	104	106	106	107	107	111	121	-	-	-
16004	111	111	113	113	114	114	118	128	-	-	-

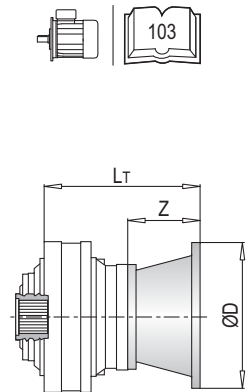

PL 16000 F - Giriş Milleri / Input Shafts / Antriebswellen / Alberi Entrata / Arbres D'entree / Ejes De Entrada

PL	EL C 28				EL C 42				EML 42				EML 1"3/8 Z6				EM 65				EM 1"3/8 Z6			
	L _T	Z	L	Ød	L _T	Z	L	Ød	L _T	Z	L	Ød	L _T	Z	L	Ød	L _T	Z	L	Ød	L _T	Z	L	Ød
16001	-	-	-	-	-	-	-	-	-	-	-	-	-	-	-	-	252.5	121.5	105	65	252.5	121.5	105	1"3/8
16002	266.5	-	-	-	266.5	-	-	-	296.5	-	-	-	296.5	-	-	-	337.5	-	-	-	337.5	-	-	-
16003	327.5	64	50	28	327.5	64	82	42	357.5	94	82	42	357.5	94	106	1"3/8	-	-	-	-	-	-	-	-
16004	375.5	-	-	-	375.5	-	-	-	405.5	-	-	-	405.5	-	-	-	-	-	-	-	-	-	-	-



PL	EP 65				PL	~ Kg						
	L _T	Z	L	Ød		EL C 28	EL C 42	EML 42	EML 1"3/8 Z6	EM 65	EM 1"3/8 Z6	EP 65
16001	284	-	-	-	16001	-	-	-	-	92.0	92.0	101.0
16002	369	153	105	65	16002	96.5	97.0	100.0	100.0	108.0	108.0	117.0
16003	-	-	-	-	16003	104.5	105.0	108.0	108.0	-	-	-
16004	-	-	-	-	16004	111.5	112.0	115.0	115.0	-	-	-

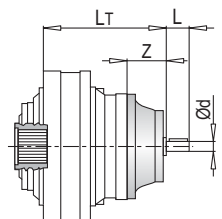

PL 16000 F - Sonsuz Dişlili Redüktör Adaptörleri (PMRV/PRV) / Worm Gearbox Adaptors (PMRV/PRV) / Anschluss Für Schneckengetriebe (PMRV/PRV) / Predisposizioni Per Riduttori A Vite Senza Fine (PMRV/PRV) / Adaptation Pour Reducteurs A Vis Sans Fin (PMRV/PRV) / Acoplamiento Para Reductores De Tornillo Sin Fin (PMRV/PRV)

PL	PMRV/PRV 050					PMRV/PRV 063					PMRV/PRV 075				
	Lm	I	h	MA	G	Lm	I	h	MA	G	Lm	I	h	MA	G
16001	-					-					-				
16002	328					337.5					316.5				
16003	389	50	110	60	80	398.5	63	135	72	95	377.5	75	161	86	112.5
16004	437					446.5					425.5				

PL	PMRV/PRV 090					PMRV/PRV 110					PMRV/PRV 130					
	Lm	I	h	MA	G	Lm	I	h	MA	G	Lm	I	h	MA	G	
16001	-					269					276.5					180
16002	326.5					354	110	237.5	127.5	160	361.5	130	277.5	147.5	180	
16003	387.5	90	193	103	129.5	-					-					
16004	435.5					-					-					

PL	PMRV/PRV ~ Kg					
	050	063	075	090	110	130
16001	-	-	-	-	121	138
16002	99	102.5	105	110	137	154
16003	107	110.5	113	118	-	-
16004	114	117.5	120	125	-	-

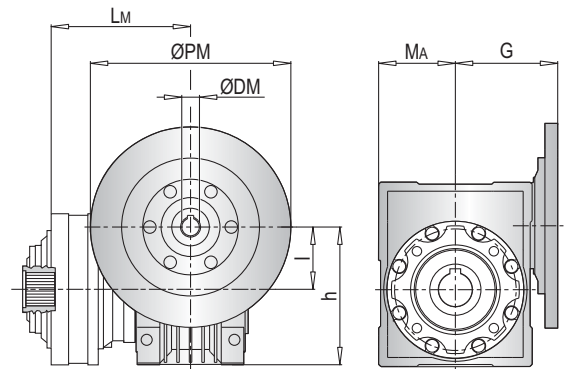

PLB 16000 F - Elektrik Motor Adaptörleri (IEC) / Electric Motor Couplings (IEC) / Anbauvorrichtung Für Elektromotore (IEC) / Predisposizioni Per Motori Elettrici (IEC) / Adaptations Pour Moteurs Electriques (IEC) / Acoplamientos Para Motores Eléctricos (IEC)

PLB	IEC 80				IEC 90				IEC 100				IEC 112				IEC 132				
	A	Lt	Z	ØD	A	Lt	Z	ØD	A	Lt	Z	ØD	A	Lt	Z	ØD	A	Lt	Z	ØD	
16002	219				219				219				219				219				
16003	304	296	56	200	304	296	56	200	304	306	66	250	304	306	66	250	304	340	100	300	
16004	338.5	216			338.5	216			338.5	226			338.5	226			338.5	260			

PLB	IEC 160				IEC 180			
	A	Lt	Z	ØD	A	Lt	Z	ØD
16002	219				219	379	139	350
16003	304	379	139	350	-			
16004	338.5	299			-			

PLB	IEC ~ Kg						
	80	90	100	112	132	160	180
16002	120	120	121	121	125	135	137
16003	139	139	140	140	144	154	-
16004	122	122	123	123	127	137	-

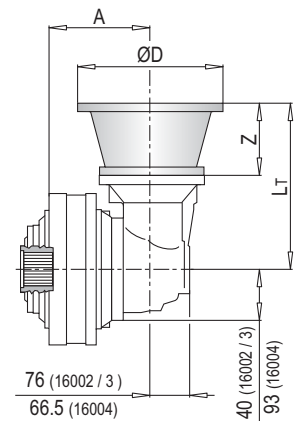

PLB 16000 F - Giriş Milleri / Input Shafts / Antriebswellen / Alberi Entrata / Arbres D'entree / Ejes De Entrada

PLB	EL C 28					EL C 42					EML 42					EML 1"3/8 Z6					EM 65					
	A	Lt	Z	L	Ød	A	Lt	Z	L	Ød	A	Lt	Z	L	Ød	A	Lt	Z	L	Ød	A	Lt	Z	L	Ød	
16002	219					219					219					219					219					
16003	304	304	64	50	28	304	304	64	82	42	304	334	94	82	42	304	334	94	106	1"3/8	304	377.5	121.5	105	65	
16004	338.5	224				338.5	224				338.5	254				338.5	254				338.5	297.5				

PLB	EM 1"3/8 Z6					EP 65					PLB	~ Kg						
	A	Lt	Z	L	Ød	A	Lt	Z	L	Ød		EL C 28	EL C 42	EML 42	EML 1"3/8 Z6	EM 65	EM 1"3/8 Z6	EP 65
16002	219					219					118.5	119.0	122.0	122.0	130.0	130.0	139.0	
16003	304	361.5	121.5	105	1"3/8	304	409	153	105	65	137.5	138.0	141.0	141.0	149.0	149.0	158.0	
16004	338.5	297.5				338.5	329				120.5	121.0	124.0	124.0	132.0	132.0	141.0	

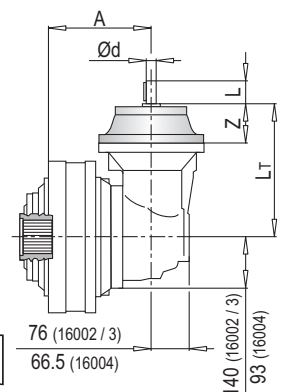

PL 16000 FS - Sansuz Dişli Redüktör Adaptörleri (PMRV/PRV) / Worm Gearbox Adaptors (PMRV/PRV) / Anschluss Für Schneckengetriebe (PMRV/PRV) / Predisposizioni Per Riduttori A Vite Senza Fine (PMRV/PRV) / Adaptation Pour Reducteurs A Vis Sans Fin (PMRV/PRV) / Acoplamiento Para Reductores De Tornillo Sin Fin (PMRV/PRV)

PL	PMRV/PRV 050					PMRV/PRV 063					PMRV/PRV 075				
	Lm	l	h	MA	G	Lm	l	h	MA	G	Lm	l	h	MA	G
16001	-					-					-				
16002	338					347.5					326.5				
16003	399	50	110	60	80	408.5	63	135	72	95	387.5	75	161	86	112.5
16004	447					456.5					435.5				

PL	PMRV/PRV 090					PMRV/PRV 110					PMRV/PRV 130				
	Lm	l	h	MA	G	Lm	l	h	MA	G	Lm	l	h	MA	G
16001	-					279	110	237.5	127.5	160	286.5	130	277.5	147.5	180
16002	336.5					364					371.5				
16003	397.5	90	193	103	129.5	-					-				
16004	445.5					-					-				

PL	PMRV/PRV ~ Kg					
	050	063	075	090	110	130
16001	-	-	-	-	158	175
16002	136	139.5	142	147	174	191
16003	144	147.5	150	155	-	-
16004	150	153.5	156	161	-	-

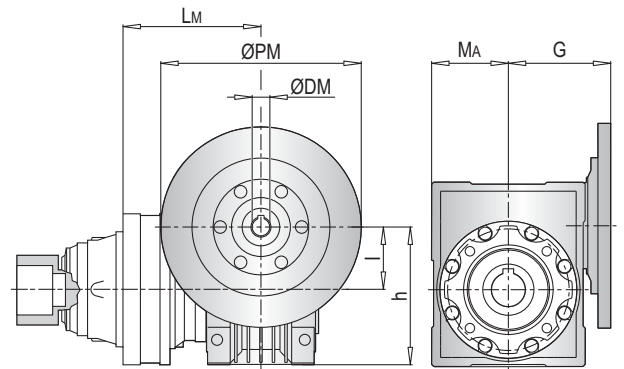

PLB 16000 FS - Elektrik Motor Adaptörleri (IEC) / Electric Motor Couplings (IEC) / Anbauvorrichtung Für Elektromotore (IEC) / Predisposizioni Per Motori Elettrici (IEC) / Adaptations Pour Moteurs Electriques (IEC) / Acoplamientos Para Motores Eléctricos (IEC)

PLB	IEC 80				IEC 90				IEC 100				IEC 112				IEC 132			
	A	Lt	Z	ØD	A	Lt	Z	ØD	A	Lt	Z	ØD	A	Lt	Z	ØD	A	Lt	Z	ØD
16002	229				229				229				229				229			
16003	314	296	56	200	314	296	56	200	314	306	66	250	314	306	66	250	314	340	100	300
16004	348.5	216			348.5	216			348.5	226			348.5	226			348.5	260		

PLB	IEC 160				IEC 180			
	A	Lt	Z	ØD	A	Lt	Z	ØD
16002	229				229	379	139	350
16003	314	379	139	350	-			
16004	348.5	229			-			

PLB	IEC ~ Kg						
	80	90	100	112	132	160	180
16002	156	156	157	157	161	171	171
16003	175	175	176	176	180	190	-
16004	158	158	159	159	163	173	-

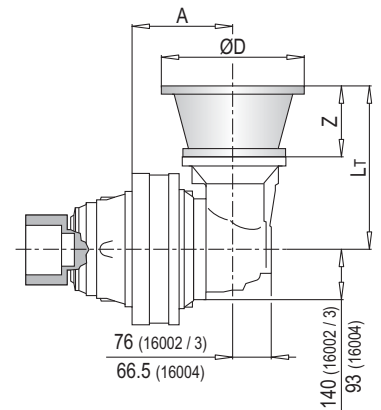

PLB 16000 FS - Giriş Milleri / Input Shafts / Antriebswellen / Alberi Entrata / Arbres D'entree / Ejes De Entrada

PLB	EL C 28					EL C 42					EML 42					EML 1"3/8 Z6					EM 65				
	A	Lt	Z	L	Ød	A	Lt	Z	L	Ød	A	Lt	Z	L	Ød	A	Lt	Z	L	Ød	A	Lt	Z	L	Ød
16002	229					229					229					229					229				
16003	314	304	64	50	28	314	304	64	82	42	314	334	94	82	42	314	334	94	106	1"3/8	314	377.5	121.5	105	65
16004	348.5	224				348.5	224				348.5	254				348.5	254				348.5	297.5			

PLB	EM 1"3/8 Z6					EP 65					PLB	~ Kg						
	A	Lt	Z	L	Ød	A	Lt	Z	L	Ød		EL C 28	EL C 42	EML 42	EML 1"3/8 Z6	EM 65	EM 1"3/8 Z6	EP 65
16002	229					229					16002	154.5	155.0	158.0	158.0	166.0	166.0	175.0
16003	314	377.5	121.5	105	1"3/8	314	409	153	105	65	16003	173.5	174.0	177.0	177.0	185.0	185.0	194.0
16004	348.5	297.5				348.5	329				16004	156.5	157.0	160.0	160.0	168.0	168.0	177.0

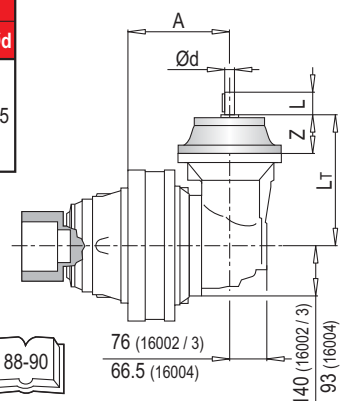

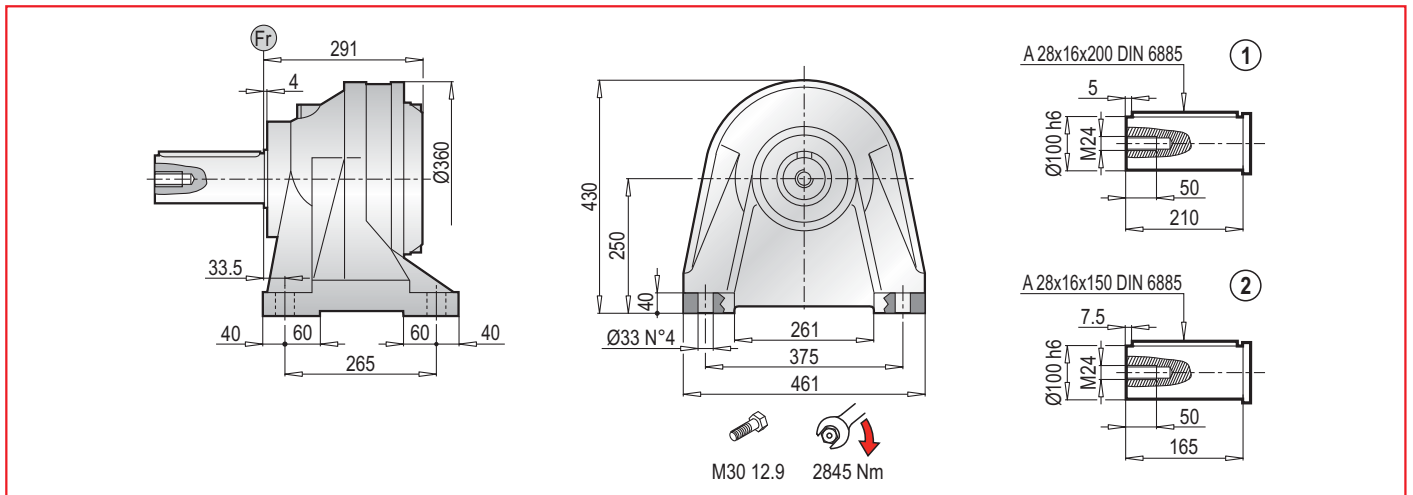

PL 16000 CPC - Elektrik Motor Adaptörleri (IEC) / Electric Motor Couplings (IEC) / Anbauvorrichtung Für Elektromotore (IEC) / Predisposizioni Per Motori Elettrici (IEC) / Adaptations Pour Moteurs Électriques (IEC) / Acoplamientos Para Motores Eléctricos (IEC)

PL	IEC 63			IEC 71			IEC 80			IEC 90			IEC 100			IEC 112		
	L _T	Z	Ød	L _T	Z	Ød	L _T	Z	Ød	L _T	Z	Ød	L _T	Z	Ød	L _T	Z	Ød
16001	-	-	-	-	-	-	-	-	-	-	-	-	-	-	-	-	-	-
16002	398.5	-	-	398.5	-	-	418.5	-	-	418.5	-	-	428.5	-	-	428.5	-	-
16003	459.5	36	140	459.5	36	160	479.5	56	200	479.5	56	200	489.5	66	250	489.5	66	250
16004	507.5	-	-	507.5	-	-	527.5	-	-	527.5	-	-	537.5	-	-	537.5	-	-

PL	IEC 132			IEC 160			IEC 180			IEC 200			IEC 225		
	L _T	Z	Ød	L _T	Z	Ød	L _T	Z	Ød	L _T	Z	Ød	L _T	Z	Ød
16001	-	-	-	409	118	350	409	118	350	439	148	400	439	148	450
16002	462.5	-	-	501.5	-	-	501.5	139	350	-	-	-	-	-	-
16003	523.5	100	300	562.5	139	350	-	-	-	-	-	-	-	-	-
16004	571.5	-	-	610.5	-	-	-	-	-	-	-	-	-	-	-

PL	IEC ~ Kg										
	63	71	80	90	100	112	132	160	180	200	225
16001	-	-	-	-	-	-	-	179	179	189	194
16002	178	178	180	180	181	181	185	195	195	-	-
16003	186	186	188	188	189	189	193	203	-	-	-
16004	192	192	194	194	195	195	199	209	-	-	-

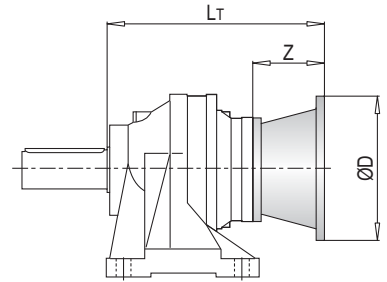
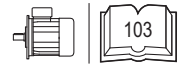

PL 16000 CPC - Giriş Milleri / Input Shafts / Antriebswellen / Alberi Entrata / Arbres D'entree / Ejes De Entrada

PL	EL C 28				EL C 42				EML 42				EML 1"3/8 Z6				EM 65				EM 1"3/8 Z6			
	L _T	Z	L	Ød	L _T	Z	L	Ød	L _T	Z	L	Ød	L _T	Z	L	Ød	L _T	Z	L	Ød	L _T	Z	L	Ød
16001	-	-	-	-	-	-	-	-	-	-	-	-	-	-	-	-	412.5	121.5	105	65	412.5	121.5	105	1"3/8
16002	426.5	-	-	-	426.5	-	-	-	456.5	-	-	-	456.5	-	-	-	497.5	-	-	-	497.5	-	-	-
16003	487.5	64	50	28	487.5	64	82	42	517.5	94	82	42	517.5	94	106	1"3/8	-	-	-	-	-	-	-	-
16004	535.5	-	-	-	535.5	-	-	-	565.5	-	-	-	565.5	-	-	-	-	-	-	-	-	-	-	-

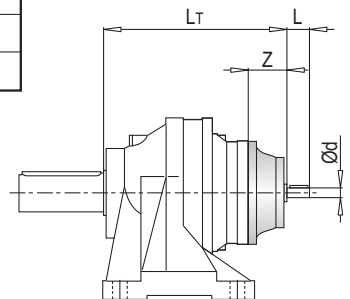

PL	EP 65				PL	~ Kg						
	L _T	Z	L	Ød		EL C 28	EL C 42	EML 42	EML 1"3/8 Z6	EM 65	EM 1"3/8 Z6	EP 65
16001	444	-	-	-	16001	-	-	-	-	174.0	174.0	183.0
16002	529	153	105	65	16002	178.5	179.0	182.0	182.0	190.0	190.0	199.0
16003	-	-	-	-	16003	186.5	187.0	190.0	190.0	-	-	-
16004	-	-	-	-	16004	192.5	193.0	196.0	196.0	-	-	-

PL 16000 CPC - Sonsuz Dişli Redüktör Adaptörleri (PMRV/PRV) / Worm Gearbox Adaptors (PMRV/PRV) / Anschluss Für Schneckengetriebe (PMRV/PRV) / Predisposizioni Per Riduttori A Vite Senza Fine (PMRV/PRV) / Adaptation Pour Reducteurs A Vis Sans Fin (PMRV/PRV) / Acoplamiento Para Reductores De Tornillo Sin Fin (PMRV/PRV)

PL	PMRV/PRV 050					PMRV/PRV 063					PMRV/PRV 075				
	Lm	l	h	MA	G	Lm	l	h	MA	G	Lm	l	h	MA	G
16001	-					-					-				
16002	488					497.5					476.5				
16003	549	50	110	60	80	558.5	63	135	72	95	537.5	75	161	86	112.5
16004	597					606.5					585.5				

PL	PMRV/PRV 090					PMRV/PRV 110					PMRV/PRV 130				
	Lm	l	h	MA	G	Lm	l	h	MA	G	Lm	l	h	MA	G
16001	-					429	110	237.5	127.5	160	436.5	130	277.5	147.5	180
16002	486.5					514					521.5				
16003	547.5	90	193	103	129.5	-					-				
16004	595.5					-					-				

PL	PMRV/PRV ~ Kg						
	050	063	075	090	110	130	
16001	-	-	-	-	203	220	
16002	181	184.5	187	192	219	236	
16003	189	192.5	195	200	-	-	
16004	195	198.5	201	206	-	-	

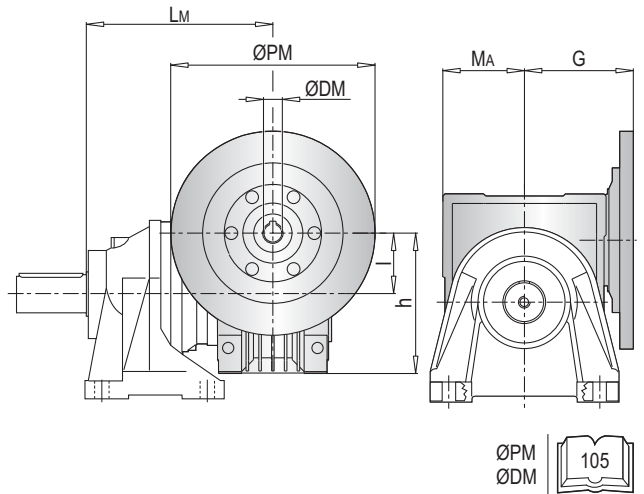

PLB 16000 CPC - Elektrik Motor Adaptörleri (IEC) / Electric Motor Couplings (IEC) / Anbauvorrichtung Für Elektromotore (IEC) / Predisposizioni Per Motori Elettrici (IEC) / Adaptations Pour Moteurs Electriques (IEC) / Acoplamientos Para Motores Eléctricos (IEC)

PLB	IEC 80				IEC 90				IEC 100				IEC 112				IEC 132			
	A	Lt	Z	ØD	A	Lt	Z	ØD	A	Lt	Z	ØD	A	Lt	Z	ØD	A	Lt	Z	ØD
16002	379	296			379	296	56	200	379	306	66	250	379	306	66	250	379	340	100	300
16003	464		56	200	464		56	200	464		66	250	464		66	250	464		100	300
16004	498.5	216			498.5	216			498.5	226			498.5	226			498.5	260		

PLB	IEC 160				IEC 180			
	A	Lt	Z	ØD	A	Lt	Z	ØD
16002	379				379	379	139	350
16003	464	379	139	350	-			
16004	498.5	299			-			

PLB	IEC ~ Kg							
	80	90	100	112	132	160	180	
16002	201	201	202	202	206	216	216	
16003	220	220	221	221	225	235	-	
16004	203	203	204	204	208	218	-	

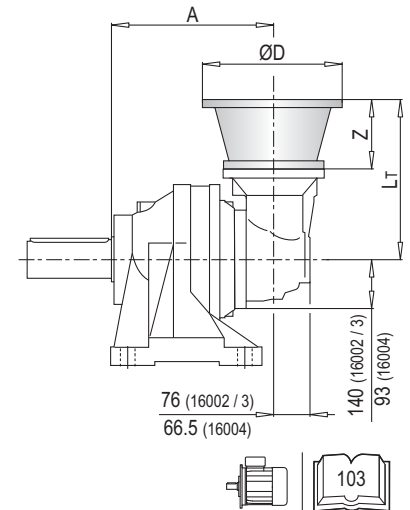

PLB 16000 CPC - Giriş Milleri / Input Shafts / Antriebswellen / Alberi Entrata / Arbres D'entree / Ejes De Entrada

PLB	EL C 28					EL C 42					EML 42					EML 1"3/8 Z6					EM 65				
	A	Lt	Z	L	Ød	A	Lt	Z	L	Ød	A	Lt	Z	L	Ød	A	Lt	Z	L	Ød	A	Lt	Z	L	Ød
16002	379					379					379					379					379	377.5	121.5	105	65
16003	464	304	64	50	28	464	304	64	82	42	464	334	94	82	42	464	334	94	106	1"3/8	464				
16004	498.5	224				498.5	224				498.5	254				498.5	254				498.5	281.5			

PLB	EM 1"3/8 Z6					EP 65				
	A	Lt	Z	L	Ød	A	Lt	Z	L	Ød
16002	379					379	409	153	105	65
16003	464	377.5	121.5	105	1"3/8	464				
16004	498.5	281.5				498.5	313			

PLB	~ Kg							
	EL C 28	EL C 42	EML 42	EML 1"3/8 Z6	EM 65	EM 1"3/8 Z6	EP 65	
16002	199.5	200.0	203.0	203.0	211.0	211.0	220.0	
16003	218.5	219.0	222.0	222.0	230.0	230.0	239.0	
16004	201.5	202.0	205.0	205.0	213.0	213.0	222.0	

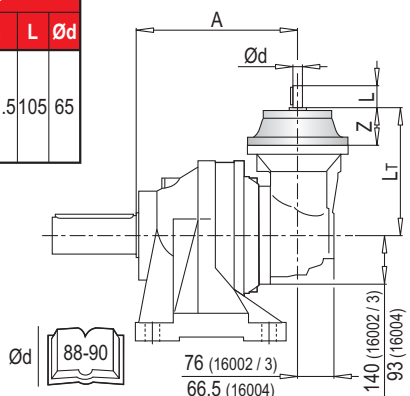

AKSESUARLAR / ACCESSORIES / ZUBEHÖR / ACCESSORI / ACCESSOIRES / ACCESORIOS

YZ Pinyon / Pinion / Ritzel
Pignoni / Pignon / Piñones



Çıkış tipi Output type Abtriebs-version Version Version Versión	M	Z	XM	A	B	C	D	E	F	G	K	Malzeme Material Material Materiale Matière Material	Kod Code Bestell-Nr. Code Code Código	
A	M	10	12	0	90	-	10	31	140	85	80	-	38NiCrMo4	1071.236.042
	M	10	14	0	90	-	10	31	160	85	80	-	38NiCrMo4	1071.238.042
	P	14	13	7	122	-	24	33	224	105	105	-	18NiCrMo5	1071.293.042
B	M	12	14	3	90	115	25	31	194.5	85	80	130	39NiCrMo3	1071.286.042

FF Sabitleme rondelası / Stop bottom plate / Endscheibe /
Fondello di arresto / Bouchon de fermeture / Tapón de detención

Kod / Code
Bestell - Nr. / Codice
Code / Código
1075.030.000

Kod / Code
Bestell - Nr. / Codice
Code / Código
1075.042.000

BS Spline kaplin / Splined bushing / Innenverzahnte Buchse /
Boccola scanalata / Moyeu cannelé / Casquillo ranurado

Malzeme / Material
Material / Materiale
Matière / Material

MS Kod / Code
Bestell - Nr. / Codice
Code / Código
6171.103.076

UNI C40
SAE 1040
DIN Ck40

PS Kod / Code
Bestell - Nr. / Codice
Code / Código
8171.112.041

KB Spline mil / Splined rod / Außenverzahnte Welle /
Barra scanalata / Arbre cannelé / Barra ranurada

Malzeme / Material
Material / Materiale
Matière / Material

UNI 39NiCrMo3
Sertleşmiş ve tavlanmış / Hardened and tempered
Vergütet / Bonifié
Bonificado / Endurecido e temperado

Kod / Code
Bestell - Nr. / Codice
Code / Código
3071.406.042

FL Flaş / Flange / Flansch
Flangia / Bride / Brida

MS Kod / Code
Bestell - Nr. / Codice
Code / Código
6171.105.098

PS Kod / Code
Bestell - Nr. / Codice
Code / Código
8171.104.098

GA Konik sıkırtma / Shrink disc / Schrumpfscheibe /
Giunto di attrito / Frette de serrage / Disco de contracción

Max. Drehmoment
Max. torque
Maksimum moment
Coppia max.
Couple max.
Momento máx.
35 kNm

Bestell - Nr. / Code
Kod / Codice
Code / Código
5109.165.000

TR

RADYAL YÜKLER (Fr)

Aşağıdaki grafikler istenilen n_2xh değerinin elde edilmesi için gerekli olan radyal yükleri ve K faktörlerini göstermektedir.

EN

RADIAL LOADS (Fr)

The following curves show the radial loads and the K factors to obtain the required n_2xh value.

DE

RADIALLAST (Fr)

In den nachstehenden Diagrammen ist die Radiallast und der Koeffizient K dargestellt und kann mit dem gewünschten Wert n_2xh verglichen werden.

IT

CARICHI RADIALI (Fr)

Nei diagrammi seguenti sono riportati i carichi radiali e i coefficienti K per rapportarli al valore n_2xh desiderato.

FR

CHARGES RADIALES (Fr)

Dans les diagrammes suivants sont indiqués les charges radiales et les facteurs K de façon à obtenir la valeur n_2xh désirée.

ES

CARGAS RADIALES (Fr)

En los siguientes diagramas se indican las cargas radiales y los coeficientes K para obtener el valor requerido n_2xh .

M - CPC*

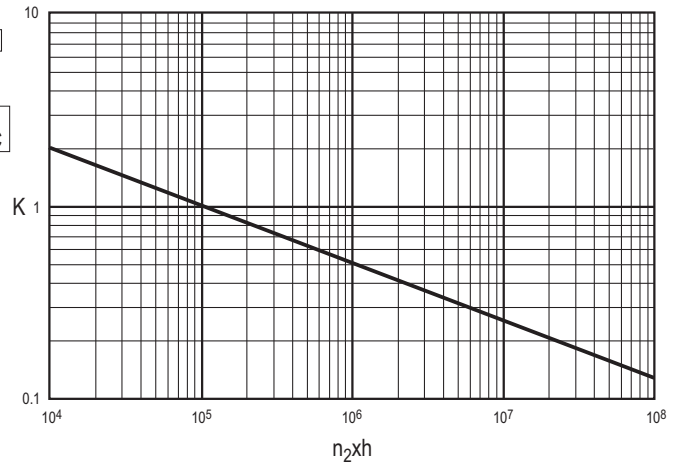
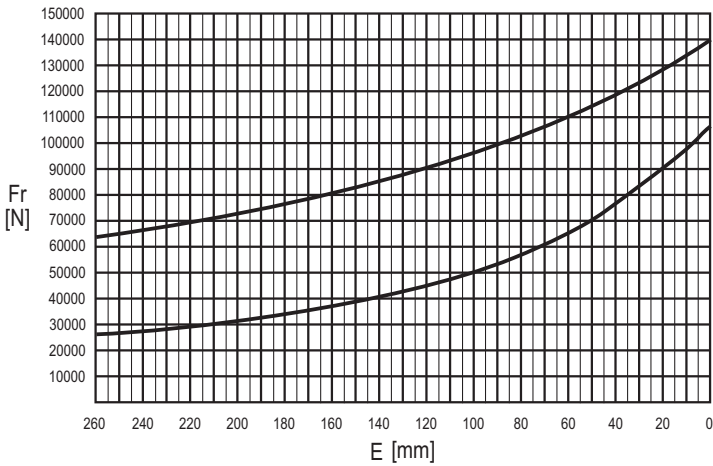

	n x h				
	10 ⁵	10 ⁴	10 ⁶	10 ⁷	10 ⁸
M	Fr			Fr • K	
CPC*	Fr • 0.75			Fr • K • 0.75	

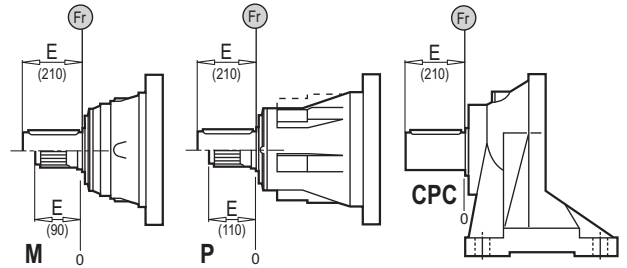

TR

EKSENEL YÜKLER (Fa)

Tabloda yer alan eksenel yük değerleri, çıkış tipine ve uygulamanın yük yönüne göre değişir.

EN

AXIAL LOADS (Fa)

The values of the axial loads in the table refer to the output versions and load direction of application.

DE

AXIALLAST (Fa)

Die dargestellten Werte der Axiallast basieren auf der Version und der applizierten Lastrichtung.

IT

CARICHI ASSIALI (Fa)

I valori dei carichi assiali indicati in tabella sono riferiti alle versioni e alla direzione di applicazione del carico.

FR

CHARGES AXIALES (Fa)

Les valeurs des charges axiales indiquées dans le tableau se réfèrent aux versions et à la direction d'application de la charge.

ES

CARGAS AXIALES (Fa)

Los valores de las cargas axiales indicados en la tabla se refieren a las versiones y a la dirección de aplicación de la carga.

Fa [N]	M - CPC	P	← →
	45000	85000	
65000	85000		

