

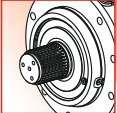





TEKNİK VERİLER / TECHNICAL DATA / TECHNISCHE DATEN / DATI TECNICI / DONNÉES TECHNIQUES / DATOS TÉCNICAS

	$i_{ges}$	$M_{max}$ ( $n_2 \times h: 20000$ ) (Nm)	OUTPUT		INPUT	
130001	4.09 ... 6.23	283300	 Ø180	 W170X5X8f DIN 5480	 Ø28 - Ø42 Ø 1"3/8 - Ø65 - Ø65	 Hydraulic Motor
130002	16.36 ... 29.32	209500	 Ø190	 N160X5X9H DIN 5480	 Electric Motor	 Worm gearboxes
130003	58.17 ... 197.89	209500				
130004	219.75 ... 1190.30	209500			 Brake	
130005	781.33 ... 5665.81	209500				

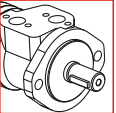
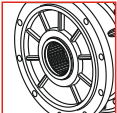
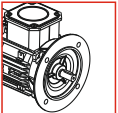
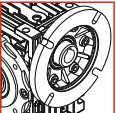
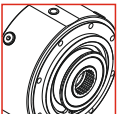
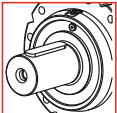
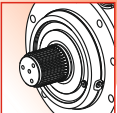
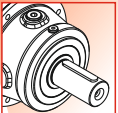
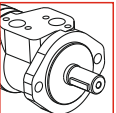
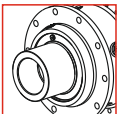
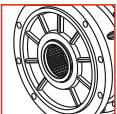
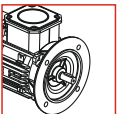
	$i_{ges}$	$M_{max}$ ( $n_2 \times h: 20000$ ) (Nm)	OUTPUT		INPUT	
130003	50.25 ... 116.29	164600	 Ø180	 W170X5X8f DIN 5480	 Ø28 - Ø42 Ø 1"3/8 - Ø65	 Hydraulic Motor
130004	200.95 ... 771.75	164600	 Ø190	 N160X5X9H DIN 5480	 Electric Motor	
130005	893.10 ... 5566.69	209500			 Brake	

	Pt [kW]	n <sub>1max</sub> [min <sup>-1</sup> ]	i <sub>ges</sub>	Mc [kNm]				Giriş- Input - Antrieb - Entrada - Entrée - Entrada			
				n <sub>2</sub> x h	n <sub>2</sub> x h	n <sub>2</sub> x h	n <sub>2</sub> x h				
				10.000	20.000	50.000	100.000	IEC (B5)	PMRV / PRV	EL - EML EM - EP - ET	
PL 130001	102	750	4.09	185.1	166.7	145.1	132.0	160   225	-	-	
			5.25	136.9	123.2	107.3	100.6	180   250			
			6.23	107.5	96.8	84.4	80.6	200   280			
PL 130002	60	1200	16.36	133.8	118.4	100.8	89.3	160	-	ET 90	
			19.25	114.0	100.9	85.9	76.0	180			
			21.00	136.9	123.2	107.3	100.6	200			
			24.71	136.9	123.2	105.5	93.3	225			
			29.32	107.5	96.8	84.4	80.6	250			
PL 130003	45	2000	58.17	132.5	117.2	99.8	88.3	160 180 200 225	110 130 150	EM 65 EM 1"3/8 Z6 EP 65 ET 90	
			68.43	114.0	100.9	85.9	76.0				
			74.67	136.9	123.2	107.3	100.6				
			90.00	136.9	123.2	105.4	93.2				
			117.60	108.7	96.2	81.8	72.5				
			139.55	107.5	96.8	84.4	80.6				
			164.18	107.5	96.8	84.4	80.6				
			197.89	107.5	96.7	82.2	72.8				
PL 130004	33	2800	219.75	132.5	117.2	99.8	88.3	63 71 80 90 100 112 132 160 180	050 063 075 090 110 130 150	EL C 28 EL C 42 EML 42 EML 1"3/8 Z6 EM 65 EM 1"3/8 Z6 EP 65	
			239.95	132.5	117.2	99.8	88.3				
			258.53	114.0	100.9	85.9	76.0				
			282.07	136.9	123.2	107.3	100.6				
			308.00	136.9	123.2	107.3	100.6				
			340.00	136.9	123.2	105.4	93.2				
			385.78	136.9	123.2	105.6	93.5				
			448.00	122.8	108.8	92.5	82.1				
			485.10	108.7	96.2	81.8	72.5				
			540.00	136.9	123.2	105.4	93.2				
			607.60	108.7	96.2	81.8	72.5				
			652.50	112.1	99.1	84.4	74.9				
			705.60	108.7	96.2	81.8	72.5				
			816.31	107.5	96.7	82.2	72.8				
			1190.30	107.5	96.8	84.4	80.6				
PL 130005	27	2800	781.33	132.5	117.2	99.8	88.3	63 71 80 90 100 112 132 160 180 200	050 063 075 090	EL C 28 EL C 42 EML 42 EML 1"3/8 Z6	
			853.14	132.5	117.2	99.8	88.3				
			941.78	132.5	117.2	99.8	88.3				
			1002.93	136.9	123.2	107.3	100.6				
			1095.11	136.9	123.2	107.3	100.6				
			1208.89	136.9	123.2	107.3	100.6				
			1371.65	136.9	123.2	105.6	93.5				
			1579.61	129.2	114.1	97.1	85.8				
			1724.80	136.9	122.7	104.4	92.3				
			1904.00	136.9	123.2	105.4	93.2				
			2160.36	136.9	123.2	105.6	93.5				
			2604.00	136.9	123.2	105.4	93.2				
			3024.00	136.9	123.2	105.4	93.2				
			3402.56	108.7	96.2	81.8	72.5				
			4037.70	107.5	96.8	84.4	80.6				
5665.81	107.5	96.8	84.4	80.6							

	Pt [kW]	n <sub>1max</sub> [min <sup>-1</sup> ]	i <sub>ges</sub>	Mc [kNm]				Giriş- Input - Antrieb - Entrada - Entrée - Entrada	
				n <sub>2</sub> x h	n <sub>2</sub> x h	n <sub>2</sub> x h	n <sub>2</sub> x h		
				10.000	20.000	50.000	100.000	IEC (B5)	EL - EML EM - EP - ET
<b>PLB 130003</b>	45	2000	50.25	80.2	65.1	49.5	40.2	160 180 200 225	EM 65 EM 1"3/8 Z6 EP 65
			59.12	89.8	72.9	55.4	45.1		
			64.50	95.5	77.5	59.0	47.8		
			75.88	106.9	86.9	66.0	53.7		
			90.05	107.5	96.8	74.5	60.5		
			116.29	92.9	79.8	60.5	49.2		
<b>PLB 130004</b>	33	2800	200.95	69.8	56.7	43.0	35.0	160 180 200	EM 65 EM 1"3/8 Z6 EP 65
			284.96	89.1	72.4	55.0	44.7		
			368.95	106.8	86.7	65.9	53.6		
			434.05	107.5	96.8	73.8	60.0		
			482.09	107.5	96.8	79.5	64.6		
			567.16	107.5	96.8	84.4	72.3		
			683.63	107.5	96.7	82.2	72.8		
			771.75	75.7	70.6	62.5	55.3		
			<b>PLB 130005</b>	25	2800	893.10	114.0		
1064.00	136.9	123.2				107.3	100.6		
1174.55	136.9	123.2				105.4	93.2		
1282.50	136.9	123.2				105.4	93.2		
1453.28	113.8	100.8				85.8	75.9		
1676.89	136.9	123.2				107.3	97.3		
1865.45	136.9	123.2				105.4	93.2		
2021.25	136.9	123.2				105.4	93.2		
2196.65	107.5	96.8				84.4	80.6		
2439.11	122.8	108.8				92.5	82.1		
2610.75	107.5	96.8				84.4	80.6		
2940.00	136.9	123.2				105.4	93.2		
3146.89	107.5	96.8				84.4	80.6		
3405.19	107.5	96.8				84.4	80.6		
3552.50	112.1	99.1				84.4	74.9		
4114.61	107.5	96.8				84.4	80.6		
4959.57	107.5	96.8				84.4	80.6		
5566.69	107.5	96.7	82.2	72.8					



$$M_{\max} = M_C \times 1.7$$

(n<sub>2</sub> x h = 20.000)

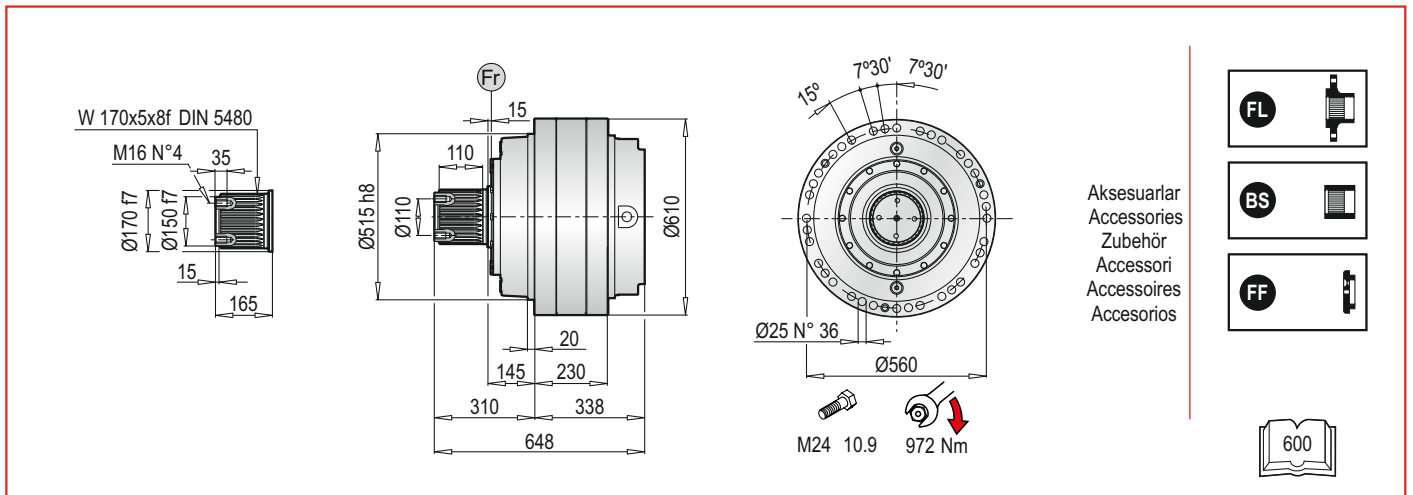

**PL 130000 MS - Elektrik Motor Adaptörleri (IEC) / Electric Motor Couplings (IEC) / Anbauvorrichtung Für Elektromotore (IEC) / Predisposizioni Per Motori Elettrici (IEC) / Adaptations Pour Moteurs Electriques (IEC) / Acoplamientos Para Motores Eléctricos (IEC)**

PL	IEC 63			IEC 71			IEC 80			IEC 90			IEC 100			IEC 112			IEC 132					
	Lt	Z	ØD	Lt	Z	ØD	Lt	Z	ØD	Lt	Z	ØD	Lt	Z	ØD	Lt	Z	ØD	Lt	Z	ØD			
130001	-	-	-	-	-	-	-	-	-	-	-	-	-	-	-	-	-	-	-	-	-	-	-	-
130002	-	-	-	-	-	-	-	-	-	-	-	-	-	-	-	-	-	-	-	-	-	-	-	-
130003	-	-	-	-	-	-	-	-	-	-	-	-	-	-	-	-	-	-	-	-	-	-	-	-
130004	729.5	36	140	729.5	36	160	749.5	56	200	749.5	56	200	759.5	66	250	759.5	66	250	793.5	100	300			
130005	790.5			790.5			810.5			810.5			820.5			820.5			854.5					

PL	IEC 160			IEC 180			IEC 200			IEC 225			IEC 250			IEC 280		
	Lt	Z	ØD	Lt	Z	ØD	Lt	Z	ØD	Lt	Z	ØD	Lt	Z	ØD	Lt	Z	ØD
130001	-	150	-	-	150	-	-	150	400	-	139	450	-	139	550	-	139	550
130002	685			685			685			674			674			-	-	-
130003	740	118	350	740	118	350	770	148		759			-	-	-	-	-	-
130004	832.5			832.5			-	-	-	-	-	-	-	-	-	-	-	-
130005	893.5	139		893.5	139		-	-	-	-	-	-	-	-	-	-	-	-

PL	IEC ~ Kg												
	63	71	80	90	100	112	132	160	180	200	225	250	280
130001	-	-	-	-	-	-	-	691	691	696	702	714	726
130002	-	-	-	-	-	-	-	834	834	839	845	857	-
130003	-	-	-	-	-	-	-	846	846	856	861	-	-
130004	843	843	845	845	846	846	850	860	860	-	-	-	-
130005	851	851	853	853	854	854	858	868	868	-	-	-	-

**PL 130000 MS - Giriş Milleri / Input Shafts / Antriebswellen / Alberi Entrata / Arbres D'entree / Ejes De Entrada**

PL	EL C 28				EL C 42				EML 42				EML 1"3/8 Z6				EM 65				EM 1"3/8 Z6			
	Lt	Z	L	Ød	Lt	Z	L	Ød	Lt	Z	L	Ød	Lt	Z	L	Ød	Lt	Z	L	Ød	Lt	Z	L	Ød
130002	-	-	-	-	-	-	-	-	-	-	-	-	-	-	-	-	-	-	-	-	-	-	-	-
130003	-	-	-	-	-	-	-	-	-	-	-	-	-	-	-	-	743.5	121.5	105	65	743.5	121.5	106	1"3/8
130004	757.5	64	50	28	757.5	64	82	42	787.5	94	82	42	787.5	94	106	1"3/8	815				815			
130005	818.5				818.5				848.5				848.5				-	-	-	-	-	-	-	-

PL	EP 65				ET 90				PL	~ Kg							
	Lt	Z	L	Ød	Lt	Z	L	Ød		EL C 28	EL C 42	EML 42	EML 1"3/8 Z6	EM 65	EM 1"3/8 Z6	EP 65	ET 90
130002	-	-	-	-	706.5	171.5	170	90	130002	-	-	-	-	-	-	-	654
130003	775	153	105	65	793.5				130003	-	-	-	-	841	841	850	872
130004	846.5				-	-	-	-	130004	843.5	844	847	847	855	855	864	-
130005	-	-	-	-	-	-	-	-	130005	851.5	852	855	855	-	-	-	-

**PL 130000 MS - Sonsuz Dişli Redüktör Adaptörleri (PMRV/PRV) / Worm Gearbox Adaptors (PMRV/PRV) / Anschluss Für Schneckengetriebe (PMRV/PRV) / Predisposizioni Per Riduttori A Vite Senza Fine (PMRV/PRV) / Adaptation Pour Reducteurs A Vis Sans Fin (PMRV/PRV) / Acoplamiento Para Reductores De Tornillo Sin Fin (PMRV/PRV)**

PL	PMRV/PRV 050					PMRV/PRV 063					PMRV/PRV 075				
	Lm	l	h	MA	G	Lm	l	h	MA	G	Lm	l	h	MA	G
130003	-					-					-				
130004	815	50	110	60	80	824.5	63	113	72	95	803.5	75	161	86	112.5
130005	876					885.5					864.5				

PL	PMRV/PRV 090					PMRV/PRV 110					PMRV/PRV 130					
	Lm	l	h	MA	G	Lm	l	h	MA	G	Lm	l	h	MA	G	
130003	-					756	110	237.5	127.5	160	761.5	130	277.5	147.5	180	
130004	813.5	90	193	103	129.5	827.5					833					
130005	874.5					-					-					

PL	PMRV/PRV 150				
	Lm	l	h	MA	G
130003	778	150	320	170	210
130004	849.5				
130005	-				

PL	PMRV/PRV ~ Kg							
	050	063	075	090	110	130	150	
130003	-	-	-	-	870	887	923	
130004	846	849.5	852	857	884	901	937	
130005	854	857.5	860	865	-	-	-	

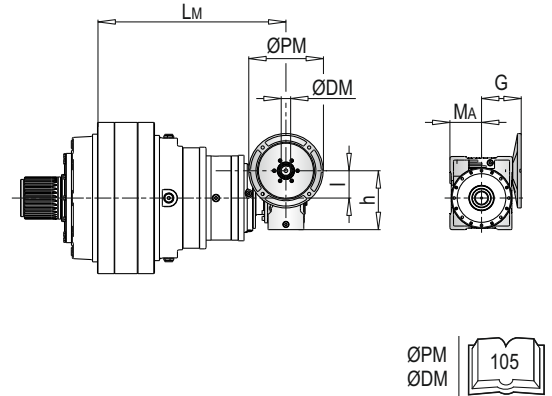

**PLB 130000 MS - Elektrik Motor Adaptörleri (IEC) / Electric Motor Couplings (IEC) / Anbauvorrichtung Für Elektromotore (IEC) / Predisposizioni Per Motori Elettrici (IEC) / Adaptations Pour Moteurs Electriques (IEC) / Acoplamientos Para Motores Eléctricos (IEC)**

PLB	IEC 80				IEC 90				IEC 100				IEC 112				IEC 132			
	A	Lt	Z	ØD	A	Lt	Z	ØD	A	Lt	Z	ØD	A	Lt	Z	ØD	A	Lt	Z	ØD
130003	-				-				-				-				-			
130004	-				-				-				-				-			
130005	795	240	56	200	795	240	56	200	795	240	66	250	795	240	66	250	795	240	100	300

PLB	IEC 160				IEC 180				IEC 200				IEC 225			
	A	Lt	Z	ØD	A	Lt	Z	ØD	A	Lt	Z	ØD	A	Lt	Z	ØD
130003	600	315	118		600	315	118	350	600	315	148	400	600	315	839	450
130004	757	315		350	757	315		350	-				-			
130005	795	240	139		795	240	139		-				-			

PLB	IEC ~ Kg									
	80	90	100	112	132	160	180	200	225	
130003	-	-	-	-	-	915	915	925	926	
130004	-	-	-	-	-	841	841	-	-	
130005	887	887	888	888	892	902	902	-	-	

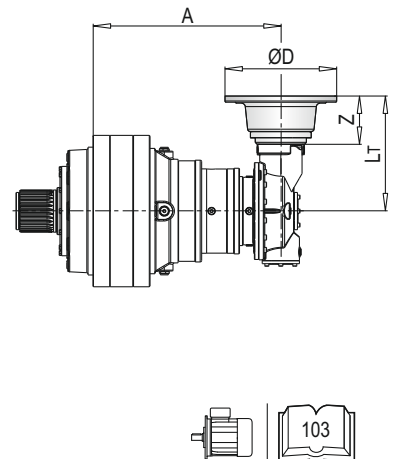

**PLB 130000 MS - Giriş Milleri / Input Shafts / Antriebswellen / Alberi Entrata / Arbres D'entree / Ejes De Entrada**

PLB	EL C 28					EL C 42					EML 42					EML 1"3/8 Z6					EM 65				
	A	Lt	Z	L	Ød	A	Lt	Z	L	Ød	A	Lt	Z	L	Ød	A	Lt	Z	L	Ød	A	Lt	Z	L	Ød
130003	-					-					-					-					600				
130004	-	-	64	50	28	-	-	64	82	42	-	-	94	82	42	-	-	94	106	1"3/8	757	436.5	121.5	105	65
130005	795	304				795	304				795	334				795	334				795	361.5			

PLB	EM 1"3/8 Z6					EP 65				
	A	Lt	Z	L	Ød	A	Lt	Z	L	Ød
130003	600					600				
130004	757	436.5	121.5	105	1"3/8	757	468	153	105	65
130005	795	361.5				795	393			

PLB	~ Kg						
	EL C 28	EL C 42	EML 42	EML 1"3/8 Z6	EM 65	EM 1"3/8 Z6	EP 65
130003	-	-	-	-	887	887	896
130004	-	-	-	-	913	913	922
130005	885.5	886	889	889	898	898	907

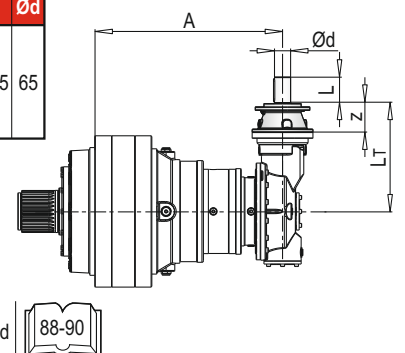

**PL/PLB 130000 MC**

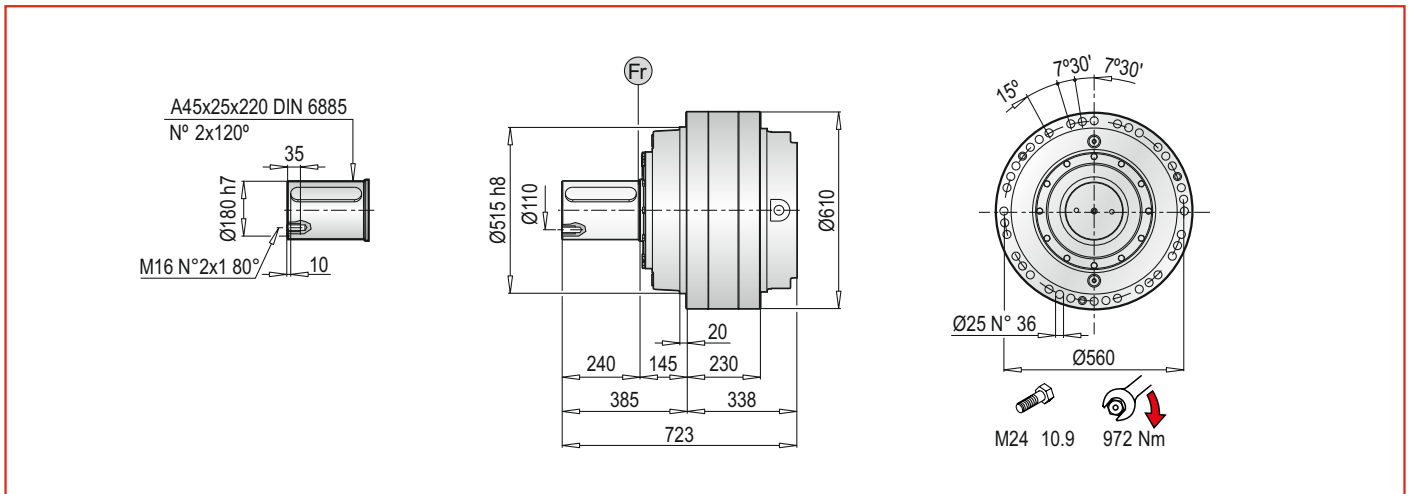

**PL 130000 MC - Elektrik Motor Adaptörleri (IEC) / Electric Motor Couplings (IEC) / Anbauvorrichtung Für Elektromotore (IEC) / Predisposizioni Per Motori Elettrici (IEC) / Adaptations Pour Moteurs Electriques (IEC) / Acoplamientos Para Motores Eléctricos (IEC)**

PL	IEC 63			IEC 71			IEC 80			IEC 90			IEC 100			IEC 112			IEC 132		
	Lt	Z	ØD	Lt	Z	ØD	Lt	Z	ØD	Lt	Z	ØD	Lt	Z	ØD	Lt	Z	ØD	Lt	Z	ØD
130001	-	-	-	-	-	-	-	-	-	-	-	-	-	-	-	-	-	-	-	-	-
130002	-	-	-	-	-	-	-	-	-	-	-	-	-	-	-	-	-	-	-	-	-
130003	-	-	-	-	-	-	-	-	-	-	-	-	-	-	-	-	-	-	-	-	-
130004	729.5	36	140	729.5	36	160	749.5	56	200	749.5	56	200	759.5	66	250	759.5	66	250	793.5	100	300
130005	790.5	-	-	790.5	-	-	810.5	-	-	810.5	-	-	820.5	-	-	820.5	-	-	854.5	-	-

PL	IEC 160			IEC 180			IEC 200			IEC 225			IEC 250			IEC 280		
	Lt	Z	ØD	Lt	Z	ØD	Lt	Z	ØD	Lt	Z	ØD	Lt	Z	ØD	Lt	Z	ØD
130001	-	150	-	-	150	-	-	150	400	-	139	450	-	139	550	-	139	550
130002	685	-	-	685	-	-	685	-	-	674	-	-	674	-	-	-	-	-
130003	740	118	350	740	118	350	770	148	-	759	-	-	-	-	-	-	-	-
130004	832.5	-	-	832.5	-	-	-	-	-	-	-	-	-	-	-	-	-	-
130005	893.5	139	-	893.5	139	-	-	-	-	-	-	-	-	-	-	-	-	-

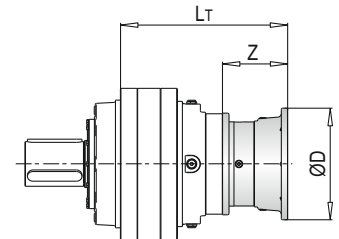
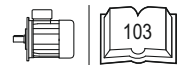

PL	IEC ~ Kg												
	63	71	80	90	100	112	132	160	180	200	225	250	280
130001	-	-	-	-	-	-	-	691	691	696	702	714	726
130002	-	-	-	-	-	-	-	834	834	839	845	857	-
130003	-	-	-	-	-	-	-	846	846	856	861	-	-
130004	843	843	845	845	846	846	850	860	860	-	-	-	-
130005	851	851	853	853	854	854	858	868	868	-	-	-	-

**PL 130000 MC - Giriş Milleri / Input Shafts / Antriebswellen / Alberi Entrata / Arbres D'entree / Ejes De Entrada**

PL	EL C 28				EL C 42				EML 42				EML 1"3/8 Z6				EM 65				EM 1"3/8 Z6			
	Lt	Z	L	Ød	Lt	Z	L	Ød	Lt	Z	L	Ød	Lt	Z	L	Ød	Lt	Z	L	Ød	Lt	Z	L	Ød
130002	-	-	-	-	-	-	-	-	-	-	-	-	-	-	-	-	-	-	-	-	-	-	-	-
130003	-	-	-	-	-	-	-	-	-	-	-	-	-	-	-	-	743.5	121.5	105	65	743.5	121.5	106	1"3/8
130004	757.5	64	50	28	757.5	64	82	42	787.5	94	82	42	787.5	94	106	1"3/8	815	-	-	-	815	-	-	-
130005	818.5	-	-	-	818.5	-	-	-	848.5	-	-	-	848.5	-	-	-	-	-	-	-	-	-	-	-

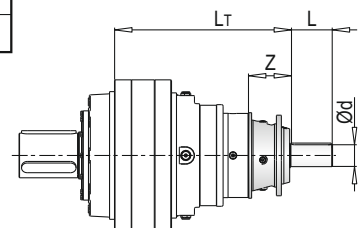

PL	EP 65				ET 90				PL	~ Kg							
	Lt	Z	L	Ød	Lt	Z	L	Ød		EL C 28	EL C 42	EML 42	EML 1"3/8 Z6	EM 65	EM 1"3/8 Z6	EP 65	ET 90
130002	-	-	-	-	706.5	171.5	170	90	130002	-	-	-	-	-	-	-	654
130003	775	153	105	65	793.5	-	-	-	130003	-	-	-	-	841	841	850	872
130004	846.5	-	-	-	-	-	-	-	130004	843.5	844	847	847	855	855	864	-
130005	-	-	-	-	-	-	-	-	130005	851.5	852	855	855	-	-	-	-

**PL 130000 MC - Sonsuz Dişlili Redüktör Adaptörleri (PMRV/PRV) / Worm Gearbox Adaptors (PMRV/PRV) / Anschluss Für Schneckengetriebe (PMRV/PRV) / Predisposizioni Per Riduttori A Vite Senza Fine (PMRV/PRV) / Adaptation Pour Reducteurs A Vis Sans Fin (PMRV/PRV) / Acoplamiento Para Reductores De Tornillo Sin Fin (PMRV/PRV)**

PL	PMRV/PRV 050					PMRV/PRV 063					PMRV/PRV 075				
	Lm	l	h	MA	G	Lm	l	h	MA	G	Lm	l	h	MA	G
130003	-					-					-				
130004	815	50	110	60	80	824.5	63	113	72	95	803.5	75	161	86	112.5
130005	876					885.5					864.5				

PL	PMRV/PRV 090					PMRV/PRV 110					PMRV/PRV 130				
	Lm	l	h	MA	G	Lm	l	h	MA	G	Lm	l	h	MA	G
130003	-					756	110	237.5	127.5	160	761.5	130	277.5	147.5	180
130004	813.5	90	193	103	129.5	827.5					833				
130005	874.5					-					-				

PL	PMRV/PRV 150				
	Lm	l	h	MA	G
130003	778	150	320	170	210
130004	849.5				
130005	-				

PL	PMRV/PRV ~ Kg							
	050	063	075	090	110	130	150	
130003	-	-	-	-	870	887	923	
130004	846	849.5	852	857	884	901	937	
130005	854	857.5	860	865	-	-	-	

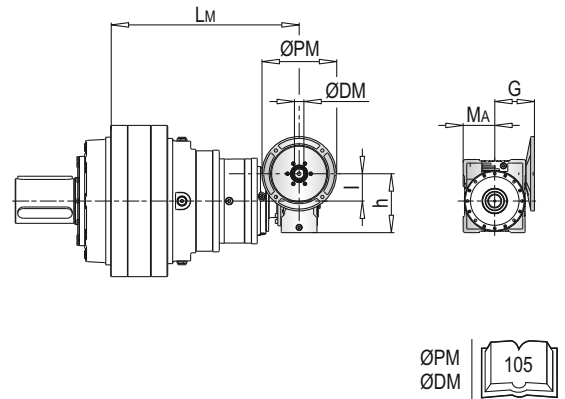

**PLB 130000 MC - Elektrik Motor Adaptörleri (IEC) / Electric Motor Couplings (IEC) / Anbauvorrichtung Für Elektromotore (IEC) / Predisposizioni Per Motori Elettrici (IEC) / Adaptations Pour Moteurs Electriques (IEC) / Acoplamientos Para Motores Eléctricos (IEC)**

PLB	IEC 80				IEC 90				IEC 100				IEC 112				IEC 132			
	A	LT	Z	ØD	A	LT	Z	ØD	A	LT	Z	ØD	A	LT	Z	ØD	A	LT	Z	ØD
130003	-				-				-				-				-			
130004	-				-				-				-				-			
130005	795	240	56	200	795	240	56	200	795	240	66	250	795	240	66	250	795	240	100	300

PLB	IEC 160				IEC 180				IEC 200				IEC 225			
	A	LT	Z	ØD	A	LT	Z	ØD	A	LT	Z	ØD	A	LT	Z	ØD
130003	600	315	118	350	600	315	118	350	600	315	148	400	600	315	839	450
130004	757				757				-				-			
130005	795	240	139		795	240	139		-				-			

PLB	IEC ~ Kg									
	80	90	100	112	132	160	180	200	225	
130003	-	-	-	-	-	915	915	925	926	
130004	-	-	-	-	-	841	841	-	-	
130005	887	887	888	888	892	902	902	-	-	

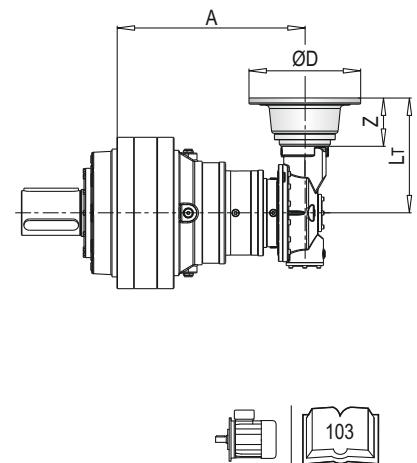

**PLB 130000 MC - Giriş Milleri / Input Shafts / Antriebswellen / Alberi Entrata / Arbres D'entree / Ejes De Entrada**

PLB	EL C 28					EL C 42					EML 42					EML 1"3/8 Z6					EM 65				
	A	LT	Z	L	Ød	A	LT	Z	L	Ød	A	LT	Z	L	Ød	A	LT	Z	L	Ød	A	LT	Z	L	Ød
130003	-					-					-					-					600				
130004	-	-	64	50	28	-	-	64	82	42	-	-	94	82	42	-	-	94	106	1"3/8	757	436.5	121.5	105	65
130005	795	304				795	304				795	334				795	334				795	361.5			

PLB	EM 1"3/8 Z6					EP 65				
	A	LT	Z	L	Ød	A	LT	Z	L	Ød
130003	600	436.5	121.5	105	1"3/8	600	468	153	105	65
130004	757					757				
130005	795	361.5				795	393			

PLB	~ Kg						
	EL C 28	EL C 42	EML 42	EML 1"3/8 Z6	EM 65	EM 1"3/8 Z6	EP 65
130003	-	-	-	-	887	887	896
130004	-	-	-	-	913	913	922
130005	885.5	886	889	889	898	898	907

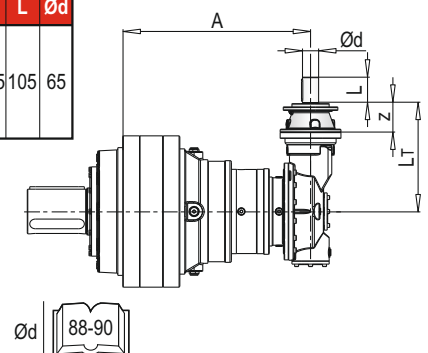

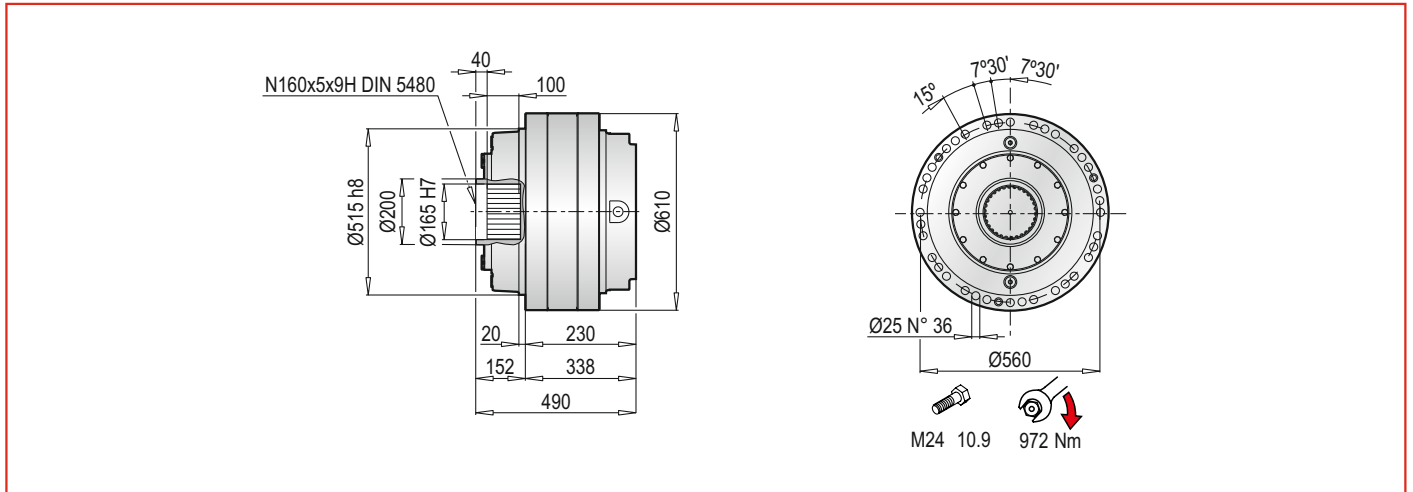

**PL 130000 F** - Elektrik Motor Adaptörleri (IEC) / Electric Motor Couplings (IEC) /Anbauvorrichtung Für Elektromotore (IEC) / Predisposizioni Per Motori Elettrici (IEC) / Adaptations Pour Moteurs Electriques (IEC) / Acoplamientos Para Motores Eléctricos (IEC)

PL	IEC 63			IEC 71			IEC 80			IEC 90			IEC 100			IEC 112			IEC 132					
	L <sub>T</sub>	Z	ØD	L <sub>T</sub>	Z	ØD	L <sub>T</sub>	Z	ØD	L <sub>T</sub>	Z	ØD	L <sub>T</sub>	Z	ØD	L <sub>T</sub>	Z	ØD	L <sub>T</sub>	Z	ØD			
130001	-	-	-	-	-	-	-	-	-	-	-	-	-	-	-	-	-	-	-	-	-	-	-	-
130002	-	-	-	-	-	-	-	-	-	-	-	-	-	-	-	-	-	-	-	-	-	-	-	-
130003	-	-	-	-	-	-	-	-	-	-	-	-	-	-	-	-	-	-	-	-	-	-	-	-
130004	729.5	36	140	729.5	36	160	749.5	56	200	749.5	56	200	759.5	66	250	759.5	66	250	793.5	100	300	793.5	100	300
130005	790.5	36	140	790.5	36	160	810.5	56	200	810.5	56	200	820.5	66	250	820.5	66	250	854.5	100	300	854.5	100	300

PL	IEC 160			IEC 180			IEC 200			IEC 225			IEC 250			IEC 280		
	L <sub>T</sub>	Z	ØD	L <sub>T</sub>	Z	ØD	L <sub>T</sub>	Z	ØD	L <sub>T</sub>	Z	ØD	L <sub>T</sub>	Z	ØD	L <sub>T</sub>	Z	ØD
130001	-	150	-	-	150	-	-	150	400	-	139	450	-	139	550	-	139	550
130002	685	118	350	685	118	350	685	148	400	674	139	450	674	139	550	-	-	-
130003	740	118	350	740	118	350	770	148	400	759	139	450	-	-	-	-	-	-
130004	832.5	139	-	832.5	139	-	-	-	-	-	-	-	-	-	-	-	-	-
130005	893.5	139	-	893.5	139	-	-	-	-	-	-	-	-	-	-	-	-	-

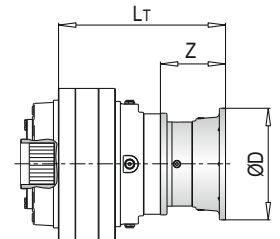

PL	IEC ~ Kg												
	63	71	80	90	100	112	132	160	180	200	225	250	280
130001	-	-	-	-	-	-	-	573	573	578	584	596	608
130002	-	-	-	-	-	-	-	716	716	721	727	739	-
130003	-	-	-	-	-	-	-	726	726	736	741	-	-
130004	723	723	725	725	726	726	730	740	740	-	-	-	-
130005	731	731	733	731	732	732	736	748	748	-	-	-	-

**PL 130000 F** - Giriş Milleri / Input Shafts / Antriebswellen / Alberi Entrata / Arbres D'entree / Ejes De Entrada

PL	EL C 28				EL C 42				EML 42				EML 1"3/8 Z6				EM 65				EM 1"3/8 Z6			
	L <sub>T</sub>	Z	L	Ød	L <sub>T</sub>	Z	L	Ød	L <sub>T</sub>	Z	L	Ød	L <sub>T</sub>	Z	L	Ød	L <sub>T</sub>	Z	L	Ød	L <sub>T</sub>	Z	L	Ød
130002	-	-	-	-	-	-	-	-	-	-	-	-	-	-	-	-	-	-	-	-	-	-	-	-
130003	-	-	-	-	-	-	-	-	-	-	-	-	-	-	-	-	743.5	121.5	105	65	743.5	121.5	106	1"3/8
130004	757.5	64	50	28	757.5	64	82	42	787.5	94	82	42	787.5	94	106	1"3/8	815	121.5	105	65	815	121.5	106	1"3/8
130005	818.5	64	50	28	818.5	64	82	42	848.5	94	82	42	848.5	94	106	1"3/8	-	-	-	-	-	-	-	-

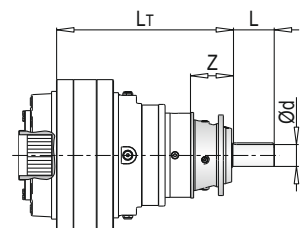

PL	EP 65				ET 90				PL	~ Kg							
	L <sub>T</sub>	Z	L	Ød	L <sub>T</sub>	Z	L	Ød		EL C 28	EL C 42	EML 42	EML 1"3/8 Z6	EM 65	EM 1"3/8 Z6	EP 65	ET 90
130002	-	-	-	-	706.5	171.5	170	90	130002	-	-	-	-	-	-	-	576
130003	775	153	105	65	793.5	171.5	170	90	130003	-	-	-	-	721	721	730	752
130004	846.5	153	105	65	-	-	-	-	130004	723.5	724	727	727	735	735	744	-
130005	-	-	-	-	-	-	-	-	130005	731.5	732	735	735	-	-	-	-

**PL 130000 F - Sonsuz Dişli Redüktör Adaptörleri (PMRV/PRV) / Worm Gearbox Adaptors (PMRV/PRV) / Anschluss Für Schneckengetriebe (PMRV/PRV) / Predisposizioni Per Riduttori A Vite Senza Fine (PMRV/PRV) / Adaptation Pour Reducteurs A Vis Sans Fin (PMRV/PRV) / Acoplamiento Para Reductores De Tornillo Sin Fin (PMRV/PRV)**

PL	PMRV/PRV 050					PMRV/PRV 063					PMRV/PRV 075				
	Lm	l	h	MA	G	Lm	l	h	MA	G	Lm	l	h	MA	G
130003	-					-					-				
130004	815	50	110	60	80	824.5	63	113	72	95	803.5	75	161	86	112.5
130005	876					885.5					864.5				

PL	PMRV/PRV 090					PMRV/PRV 110					PMRV/PRV 130				
	Lm	l	h	MA	G	Lm	l	h	MA	G	Lm	l	h	MA	G
130003	-					756	110	237.5	127.5	160	761.5	130	277.5	147.5	180
130004	813.5	90	193	103	129.5	827.5					833				
130005	874.5					-					-				

PL	PMRV/PRV 150				
	Lm	l	h	MA	G
130003	778	150	320	170	210
130004	849.5				
130005	-				

PL	PMRV/PRV ~ Kg							
	050	063	075	090	110	130	150	
130003	-	-	-	-	750	767	803	
130004	726	729.5	732	737	764	781	817	
130005	734	737.5	740	745	-	-	-	

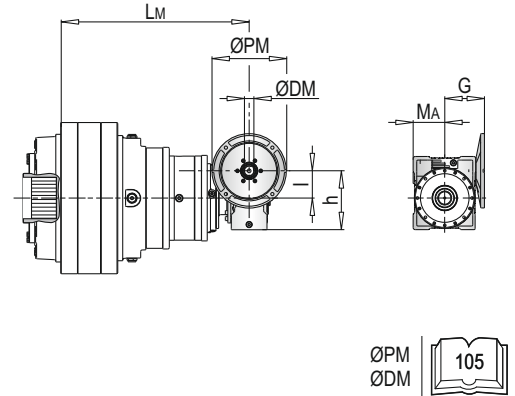

**PLB 130000 F - Elektrik Motor Adaptörleri (IEC) / Electric Motor Couplings (IEC) / Anbauvorrichtung Für Elektromotore (IEC) / Predisposizioni Per Motori Elettrici (IEC) / Adaptations Pour Moteurs Electriques (IEC) / Acoplamientos Para Motores Eléctricos (IEC)**

PLB	IEC 80				IEC 90				IEC 100				IEC 112				IEC 132			
	A	LT	Z	ØD	A	LT	Z	ØD	A	LT	Z	ØD	A	LT	Z	ØD	A	LT	Z	ØD
130003	-				-				-				-				-			
130004	-				-				-				-				-			
130005	795	240	56	200	795	240	56	200	795	240	66	250	795	240	66	250	795	240	100	300

PLB	IEC 160				IEC 180				IEC 200				IEC 225			
	A	LT	Z	ØD	A	LT	Z	ØD	A	LT	Z	ØD	A	LT	Z	ØD
130003	600	315	118	350	600	315	118	350	600	315	148	400	600	315	839	450
130004	757				757				-				-			
130005	795	240	139		795	240	139		-				-			

PLB	IEC ~ Kg									
	80	90	100	112	132	160	180	200	225	
130003	-	-	-	-	-	768	768	778	783	
130004	-	-	-	-	-	794	794	-	-	
130005	767	767	768	768	772	782	782	-	-	

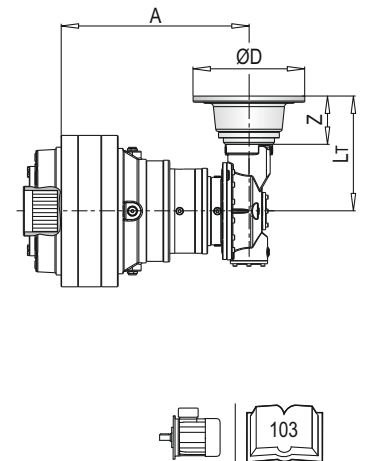

**PLB 130000 F - Giriş Milleri / Input Shafts / Antriebswellen / Alberi Entrata / Arbres D'entree / Ejes De Entrada**

PLB	EL C 28					EL C 42					EML 42					EML 1"3/8 Z6					EM 65				
	A	LT	Z	L	Ød	A	LT	Z	L	Ød	A	LT	Z	L	Ød	A	LT	Z	L	Ød	A	LT	Z	L	Ød
130003	-					-					-					-					600				
130004	-	-	64	50	28	-	-	64	82	42	-	-	94	82	42	-	-	94	106	1"3/8	757	436.5	121.5	105	65
130005	795	304				795	304				795	334				795	334				795	361.5			

PLB	EM 1"3/8 Z6					EP 65				
	A	LT	Z	L	Ød	A	LT	Z	L	Ød
130003	600	436.5				600	468			
130004	757		121.5	105	1"3/8	757		153	105	65
130005	795	361.5				795	393			

PLB	~ Kg						
	EL C 28	EL C 42	EML 42	EML 1"3/8 Z6	EM 65	EM 1"3/8 Z6	EP 65
130003	-	-	-	-	721	721	730
130004	-	-	-	-	735	735	744
130005	731.5	732	735	735	743	743	752

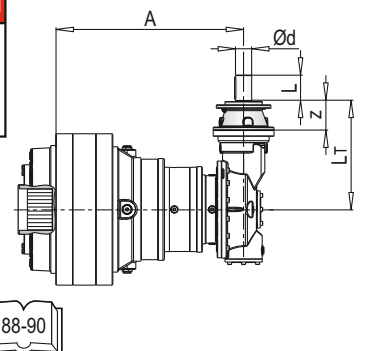

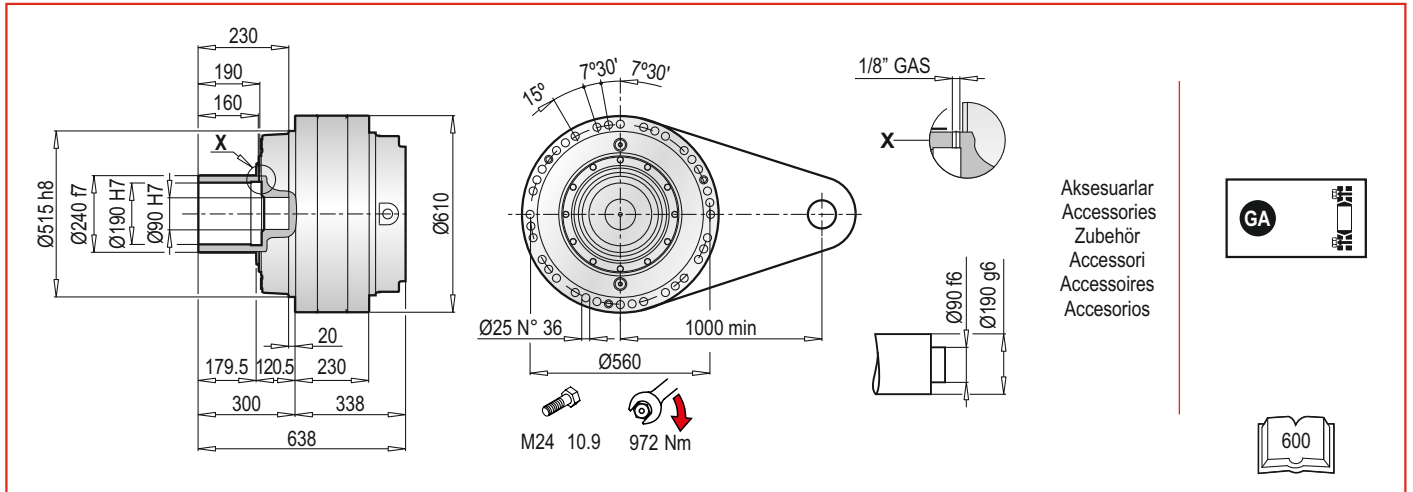

**PL 130000 FS - Elektrik Motor Adaptörleri (IEC) / Electric Motor Couplings (IEC) / Anbauvorrichtung Für Elektromotore (IEC) / Predisposizioni Per Motori Elettrici (IEC) / Adaptations Pour Moteurs Electriques (IEC) / Acoplamientos Para Motores Eléctricos (IEC)**

PL	IEC 63			IEC 71			IEC 80			IEC 90			IEC 100			IEC 112			IEC 132					
	LT	Z	ØD	LT	Z	ØD	LT	Z	ØD	LT	Z	ØD	LT	Z	ØD	LT	Z	ØD	LT	Z	ØD			
130001	-	-	-	-	-	-	-	-	-	-	-	-	-	-	-	-	-	-	-	-	-	-	-	-
130002	-	-	-	-	-	-	-	-	-	-	-	-	-	-	-	-	-	-	-	-	-	-	-	-
130003	-	-	-	-	-	-	-	-	-	-	-	-	-	-	-	-	-	-	-	-	-	-	-	-
130004	729.5	36	140	729.5	36	160	749.5	56	200	749.5	56	200	759.5	66	250	759.5	66	250	793.5	100	300	-	-	-
130005	790.5	-	-	790.5	-	-	810.5	-	-	810.5	-	-	820.5	-	-	820.5	-	-	854.5	-	-	-	-	-

PL	IEC 160			IEC 180			IEC 200			IEC 225			IEC 250			IEC 280					
	LT	Z	ØD	LT	Z	ØD	LT	Z	ØD	LT	Z	ØD	LT	Z	ØD	LT	Z	ØD			
130001	-	-	-	-	-	-	-	-	-	-	-	-	-	-	-	-	-	-	-	-	-
130002	685	150	-	685	150	-	685	150	400	674	139	450	674	139	550	-	-	-	-	-	-
130003	740	118	350	740	118	350	770	148	-	759	-	-	-	-	-	-	-	-	-	-	-
130004	832.5	-	-	832.5	-	-	-	-	-	-	-	-	-	-	-	-	-	-	-	-	-
130005	893.5	139	-	893.5	139	-	-	-	-	-	-	-	-	-	-	-	-	-	-	-	-

PL	IEC ~ Kg												
	63	71	80	90	100	112	132	160	180	200	225	250	280
130001	-	-	-	-	-	-	-	600	600	605	611	623	635
130002	-	-	-	-	-	-	-	743	743	748	754	766	-
130003	-	-	-	-	-	-	-	753	753	763	768	-	-
130004	750	750	752	752	753	753	757	767	767	-	-	-	-
130005	758	758	760	760	761	761	765	775	775	-	-	-	-

**PL 130000 FS - Giriş Milleri / Input Shafts / Antriebswellen / Alberi Entrata / Arbres D'entree / Ejes De Entrada**

PL	EL C 28				EL C 42				EML 42				EML 1"3/8 Z6				EM 65				EM 1"3/8 Z6			
	LT	Z	L	Ød	LT	Z	L	Ød	LT	Z	L	Ød	LT	Z	L	Ød	LT	Z	L	Ød	LT	Z	L	Ød
130002	-	-	-	-	-	-	-	-	-	-	-	-	-	-	-	-	-	-	-	-	-	-	-	-
130003	-	-	-	-	-	-	-	-	-	-	-	-	-	-	-	-	743.5	121.5	105	65	743.5	121.5	106	1"3/8
130004	757.5	64	50	28	757.5	64	82	42	787.5	94	82	42	787.5	94	106	1"3/8	815	-	-	-	815	-	-	-
130005	818.5	-	-	-	818.5	-	-	-	848.5	-	-	-	848.5	-	-	-	-	-	-	-	-	-	-	-

PL	EP 65				ET 90				PL	~ Kg							
	LT	Z	L	Ød	LT	Z	L	Ød		EL C 28	EL C 42	EML 42	EML 1"3/8 Z6	EM 65	EM 1"3/8 Z6	EP 65	ET 90
130002	-	-	-	-	706.5	171.5	170	90	130002	-	-	-	-	-	-	-	603
130003	775	153	105	65	793.5	-	-	-	130003	-	-	-	-	748	748	757	769
130004	846.5	-	-	-	-	-	-	-	130004	750.5	751	754	754	762	762	771	-
130005	-	-	-	-	-	-	-	-	130005	758.5	759	762	762	-	-	-	-

**PL 130000 FS** - Sonsuz Dişli Redüktör Adaptörleri (PMRV/PRV) / Worm Gearbox Adaptors (PMRV/PRV) / Anschluss Für Schneckengetriebe (PMRV/PRV) / Predisposizioni Per Riduttori A Vite Senza Fine (PMRV/PRV) / Adaptation Pour Reducteurs A Vis Sans Fin (PMRV/PRV) / Acoplamiento Para Reductores De Tornillo Sin Fin (PMRV/PRV)

PL	PMRV/PRV 050					PMRV/PRV 063					PMRV/PRV 075				
	Lm	l	h	MA	G	Lm	l	h	MA	G	Lm	l	h	MA	G
130003	-					-					-				
130004	815	50	110	60	80	824.5	63	113	72	95	803.5	75	161	86	112.5
130005	876					885.5					864.5				

PL	PMRV/PRV 090					PMRV/PRV 110					PMRV/PRV 130					
	Lm	l	h	MA	G	Lm	l	h	MA	G	Lm	l	h	MA	G	
130003	-					756	110	237.5	127.5	160	761.5	130	277.5	147.5	180	
130004	813.5	90	193	103	129.5	827.5					833					
130005	874.5					-					-					

PL	PMRV/PRV 150				
	Lm	l	h	MA	G
130003	778	150	320	170	210
130004	849.5				
130005	-				

PL	PMRV/PRV ~ Kg							
	050	063	075	090	110	130	150	
130003	-	-	-	-	777	794	830	
130004	753	756.5	759	764	791	808	844	
130005	761	764.5	767	771	-	-	-	

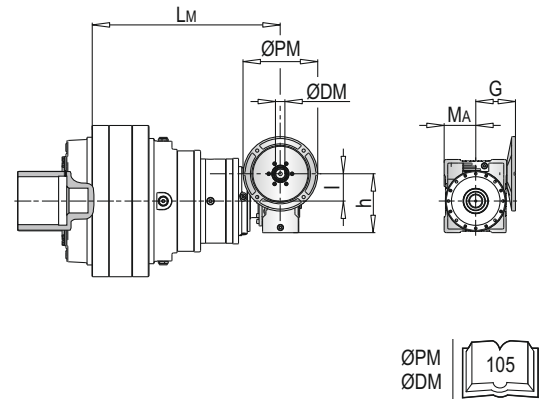

**PLB 130000 FS** - Elektrik Motor Adaptörleri (IEC) / Electric Motor Couplings (IEC) / Anbauvorrichtung Für Elektromotore (IEC) / Predisposizioni Per Motori Elettrici (IEC) / Adaptations Pour Moteurs Électriques (IEC) / Acoplamientos Para Motores Eléctricos (IEC)

PLB	IEC 80				IEC 90				IEC 100				IEC 112				IEC 132			
	A	LT	Z	ØD	A	LT	Z	ØD	A	LT	Z	ØD	A	LT	Z	ØD	A	LT	Z	ØD
130003	-				-				-				-				-			
130004	-				-				-				-				-			
130005	795	240	56	200	795	240	56	200	795	240	66	250	795	240	66	250	795	240	100	300

PLB	IEC 160				IEC 180				IEC 200				IEC 225			
	A	LT	Z	ØD	A	LT	Z	ØD	A	LT	Z	ØD	A	LT	Z	ØD
130003	600	315	118	350	600	315	118	350	600	315	148	400	600	315	839	450
130004	757				757				-				-			
130005	795	240	139		795	240	139		-				-			

PLB	IEC ~ Kg									
	80	90	100	112	132	160	180	200	225	
130003	-	-	-	-	-	795	795	805	810	
130004	-	-	-	-	-	821	821	-	-	
130005	794	794	795	795	799	809	809	-	-	

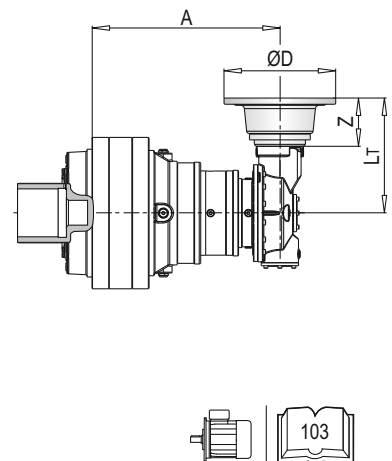

**PLB 130000 FS** - Giriş Milleri / Input Shafts / Antriebswellen / Alberi Entrata / Arbres D'entree / Ejes De Entrada

PLB	EL C 28					EL C 42					EML 42					EML 1"3/8 Z6					EM 65				
	A	LT	Z	L	Ød	A	LT	Z	L	Ød	A	LT	Z	L	Ød	A	LT	Z	L	Ød	A	LT	Z	L	Ød
130003	-					-					-					-					600				
130004	-	-	64	50	28	-	-	64	82	42	-	-	94	82	42	-	-	94	106	1"3/8	757	436.5	121.5	105	65
130005	795	304				795	304				795	334				795	334				795	361.5			

PLB	EM 1"3/8 Z6					EP 65				
	A	LT	Z	L	Ød	A	LT	Z	L	Ød
130003	600					600				
130004	757	436.5	121.5	105	1"3/8	757	468	153	105	65
130005	795	361.5				795	393			

PLB	~ Kg						
	EL C 28	EL C 42	EML 42	EML 1"3/8 Z6	EM 65	EM 1"3/8 Z6	EP 65
130003	-	-	-	-	748	748	757
130004	-	-	-	-	762	762	771
130005	758.5	759	762	762	770	770	779

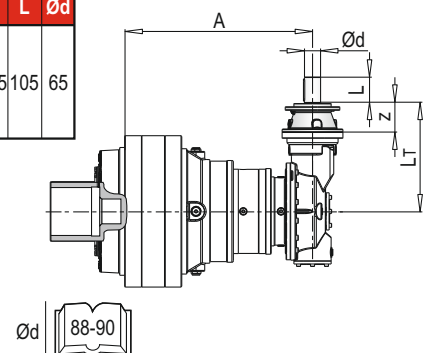

AKSESUARLAR / ACCESSORIES / ZUBEHÖR / ACCESSORI / ACCESSOIRES / ACCESORIOS

**BS** Spline kaplin / Splined bushing / Innenverzahrte Buchse  
Boccola scanalata / Moyeu cannelé / Casquillo ranurado

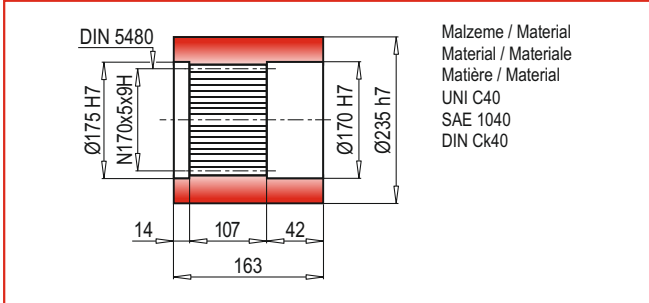

**FF** Sabitleme rondelası / Stop bottom plate / Endscheibe  
Fondello di arresto / Bouchon de fermeture / Tapón de detención

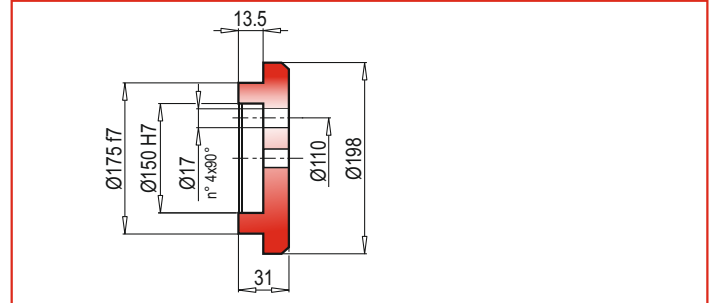

**FL** Flanş / Flange / Flansch  
Flangia / Bride / Brida

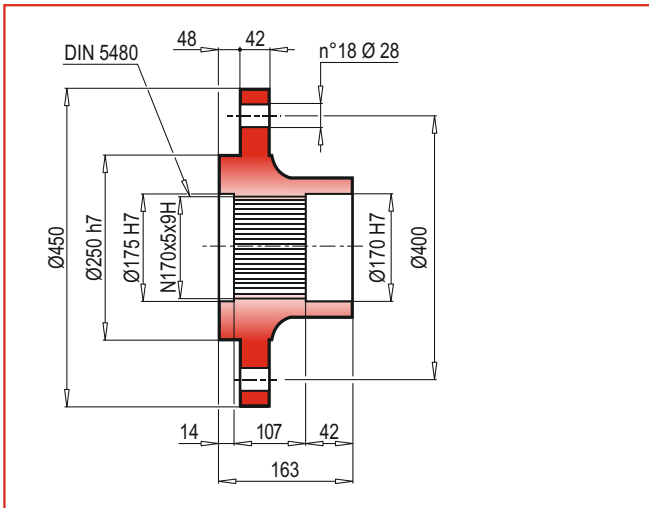

**GA** Konik sıkırma / Shrink disc / Schrumpfscheibe  
Giunto di attrito / Frette de serrage / Disco de contracción

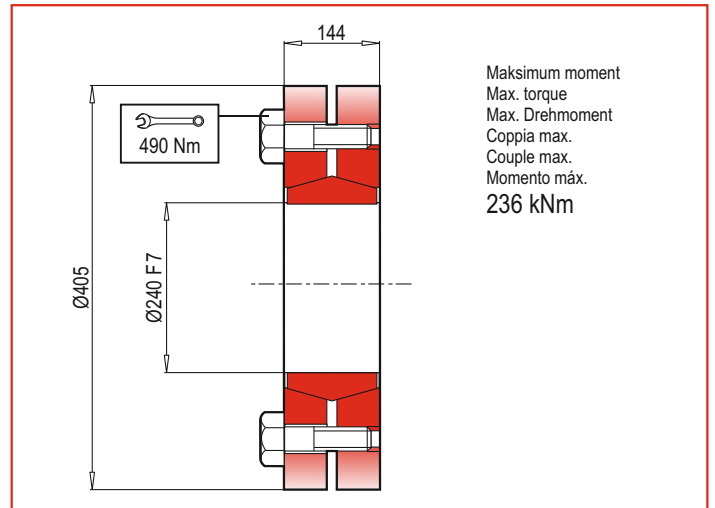

TR

**RADYAL YÜKLER (Fr)**

Aşağıdaki grafikler istenilen  $n_2xh$  değerinin elde edilmesi için gerekli olan radyal yükleri ve K faktörlerini göstermektedir.

EN

**RADIAL LOADS (Fr)**

The following curves show the radial loads and the K factors to obtain the required  $n_2xh$  value.

DE

**RADIALLAST (Fr)**

In den nachstehenden Diagrammen ist die Radiallast und der Koeffizient K dargestellt und kann mit dem gewünschten Wert  $n_2xh$  verglichen werden.

IT

**CARICHI RADIALI (Fr)**

Nei diagrammi seguenti sono riportati i carichi radiali e i coefficienti K per rapportarli al valore  $n_2xh$  desiderato.

FR

**CHARGES RADIALES (Fr)**

Dans les diagrammes suivants sont indiqués les charges radiales et les facteurs K de façon à obtenir la valeur  $n_2xh$  désirée.

ES

**CARGAS RADIALES (Fr)**

En los siguientes diagramas se indican las cargas radiales y los coeficientes K para obtener el valor requerido  $n_2xh$ .

**M**

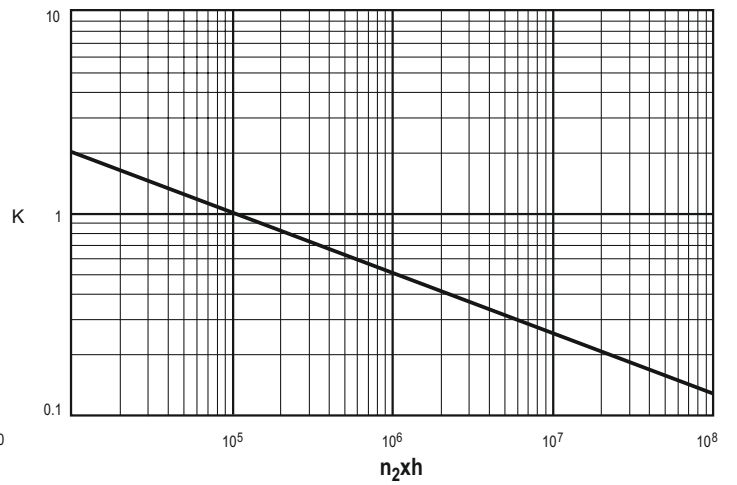
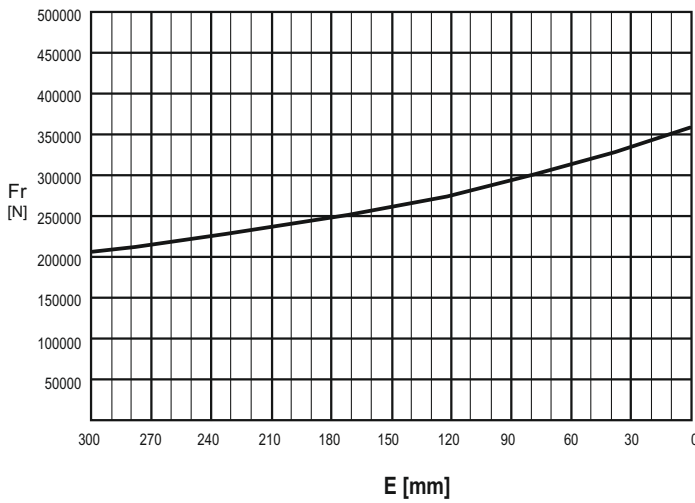

M	$n_2xh$				
	10 <sup>5</sup>	10 <sup>4</sup>	10 <sup>6</sup>	10 <sup>7</sup>	10 <sup>8</sup>
	Fr		Fr · K		

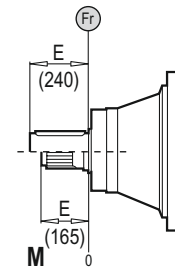

TR

**EKSENEL YÜKLER (Fa)**

Tabloda yer alan eksenel yük değerleri, çıkış tipine ve uygulamanın yük yönüne göre değişir.

EN

**AXIAL LOADS (Fa)**

The values of the axial loads in the table refer to the output versions and load direction of application.

DE

**AXIALLAST (Fa)**

Die dargestellten Werte der Axiallast basieren auf der Version und der applizierten Lastrichtung.

IT

**CARICHI ASSIALI (Fa)**

I valori dei carichi assiali indicati in tabella sono riferiti alle versioni e alla direzione di applicazione del carico.

FR

**CHARGES AXIALES (Fa)**

Les valeurs des charges axiales indiquées dans le tableau se réfèrent aux versions et à la direction d'application de la charge.

ES

**CARGAS AXIALES (Fa)**

Los valores de las cargas axiales indicados en la tabla se refieren a las versiones y a la dirección de aplicación de la carga.

Fa [N]	M	
	75000	←
65250	→	

