

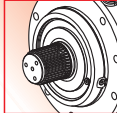





TEKNİK VERİLER / TECHNICAL DATA / TECHNISCHE DATEN / DATI TECNICI / DONNÉES TECHNIQUES / DATOS TÉCNICAS

	i_{ges}	M_{max} ($n_2 \times h: 20000$) (Nm)	OUTPUT		INPUT	
300001	3.43 ... 5.25	669000				
			Ø290	W280X5X54X8f DIN 5480	Ø28 - Ø42 Ø1"3/8 - Ø65 - Ø90	Hydraulic Motor
300002	14.03 ... 29.64	568800				
			Ø295	N240X5X9H DIN 5480	Electric Motor	Worm gearboxes
300003	56.11 ... 167.92	568800				
					Brake	
300004	199.52 ... 973.95	568800				
300005	1154.57 ... 8522.08	568800				

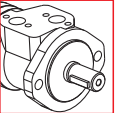
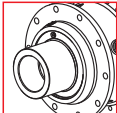
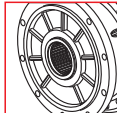
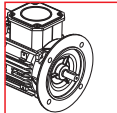
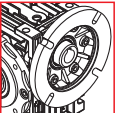
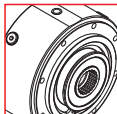
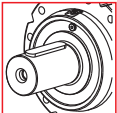
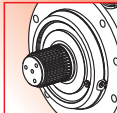
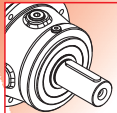
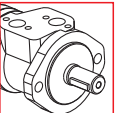
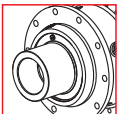
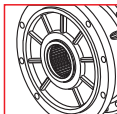
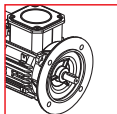
	i_{ges}	M_{max} ($n_2 \times h: 20000$) (Nm)	OUTPUT		INPUT	
300004	264.13 ... 783.64	500700				
			Ø290	W280X5X54X8f DIN 5480	Ø28 - Ø42 Ø1"3/8 - Ø65	Hydraulic Motor
300005	931.09 ... 6399.72	568800				
			Ø295	N240X5X9H DIN 5480	Electric Motor	
						
					Brake	

	Pt [kW]	n _{1max} [min ⁻¹]	i _{ges}	Mc [kNm]				Giriş- Input - Antrieb - Entrata - Entrée - Entrada				
				n ₂ x h	n ₂ x h	n ₂ x h	n ₂ x h				EL - EML EM - EP - ET	
				10.000	20.000	50.000	100.000					
PL 300001	214	200	3.43	351.0	316.0	275.1	247.8	160 180	200 225	250 280	-	-
			4.09	412.8	371.7	323.5	291.2					
			5.25	309.0	278.2	242.1	227.0					
PL 300002	110	750	14.03	351.0	316.0	275.1	247.8	160 180 200 225 250 280	-	-		
			16.54	353.2	312.6	266.0	235.5					
			18.01	351.0	316.0	275.1	247.8					
			21.23	309.0	278.2	242.1	227.0					
			25.48	346.9	312.3	271.9	259.9					
			29.64	148.0	131.0	111.5	98.6					
PL 300003	81	1500	56.11	351.0	316.0	269.9	238.9	160 180 200 225 250 280	-	ET 90		
			66.15	336.6	297.9	253.6	224.4					
			72.03	351.0	316.0	275.1	247.8					
			84.74	351.0	316.0	275.1	247.8					
			107.47	309.0	278.2	242.1	227.0					
			129.71	309.0	278.2	242.1	227.0					
			139.71	309.0	278.2	242.1	227.0					
			167.92	299.5	265.1	225.6	199.6					
PL 300004	65	2800	199.52	351.0	313.9	267.0	236.4	160 180 200 225 250	110 130 150	EM 65 EM 1"3/8 Z6 EP 65		
			256.11	351.0	316.0	275.1	247.8					
			308.70	351.0	316.0	275.1	247.8					
			394.06	309.0	278.2	242.1	227.0					
			433.06	309.0	278.2	242.1	227.0					
			488.86	309.0	278.2	240.8	213.1					
			555.88	309.0	278.2	242.1	227.0					
			618.72	309.0	278.2	242.1	227.0					
			698.56	309.0	278.2	242.1	227.0					
			743.66	299.5	265.1	225.6	199.6					
			839.61	299.5	265.1	225.6	199.6					
			973.95	299.5	265.1	225.6	199.6					
PL 300005	55	2800	1154.57	353.0	312.5	265.9	235.3	63 71 80 90 100 112 132 160 180	050 063 075 090 110 130 150	EL C 28 EL C 42 EML 42 EML 1"3/8 Z6 EM 65 EM 1"3/8 Z6 EP 65		
			1273.39	351.0	316.0	275.1	247.8					
			1391.67	353.0	312.5	265.9	235.3					
			1529.06	309.0	278.2	240.8	213.1					
			1594.95	351.0	316.0	275.1	247.8					
			1669.60	309.0	278.2	240.8	213.1					
			1743.10	353.0	312.5	265.9	235.3					
			1846.79	309.0	278.2	240.8	213.1					
			1935.27	309.0	278.2	242.1	227.0					
			2024.24	353.0	312.5	265.9	235.3					
			2113.14	309.0	278.2	242.1	227.0					
			2277.65	313.2	277.2	235.7	208.9					
			2364.35	309.0	276.1	235.2	208.0					
			2525.76	309.0	278.2	240.8	213.1					
			2646.76	309.0	278.2	242.1	227.0					
			2767.06	309.0	278.2	242.1	227.0					
			2855.65	309.0	278.2	239.6	212.4					
			3609.22	309.0	278.2	242.1	227.0					
			4485.75	309.0	278.2	242.1	227.0					
			5064.55	309.0	278.2	242.1	227.0					
			6347.48	309.0	278.2	242.1	227.0					
			8522.08	276.2	244.5	208.3	184.2					

	Pt [kW]	n _{1max} [min ⁻¹]	i _{ges}	Mc [kNm]				Giriş- Input - Antrieb - Entrada - Entrée - Entrada	
				n ₂ x h	n ₂ x h	n ₂ x h	n ₂ x h		
				10.000	20.000	50.000	100.000	IEC (B5)	EL - EML EM - EP - ET
PLB 300004	56	2500	264.13	256.0	208.0	158.1	128.4	160 180 200 225 250	EM 65 EM 1"3/8 Z6 EP 65
			339.05	304.9	247.8	188.3	153.0		
			429.11	309.0	278.2	222.1	180.3		
			515.76	299.5	265.1	225.6	199.6		
			605.29	309.0	253.0	192.1	156.0		
			651.99	309.0	266.4	202.3	164.2		
			783.64	299.5	265.1	225.6	186.8		
			PLB 300005	48	2800	931.09	351.0		
1036.22	353.0	312.5				265.9	235.3		
1195.16	351.0	316.0				275.1	236.2		
1338.25	352.4	312.0				265.6	235.0		
1457.55	332.8	294.6				250.5	222.1		
1574.41	353.0	312.5				265.9	235.3		
1688.78	300.4	244.1				185.4	150.7		
1769.68	309.0	252.1				191.7	155.7		
1829.33	309.0	278.2				242.1	227.0		
1906.68	285.8	253.1				201.9	164.0		
2020.94	309.0	278.2				242.1	227.0		
2137.41	309.0	278.2				218.7	177.7		
2214.57	332.8	294.6				250.5	222.1		
2413.20	309.0	278.2				238.1	193.4		
2569.00	299.5	265.1				225.6	199.6		
2900.48	299.5	265.1				225.6	199.6		
3364.56	299.5	265.1				225.6	199.6		
4571.23	299.5	265.1				225.6	196.4		
5302.63	299.5	265.1				225.6	199.6		
6399.72	276.2	244.5				208.3	184.2		



$$M_{\max} = M_C \times 1.8$$

(n₂ x h = 20.000)

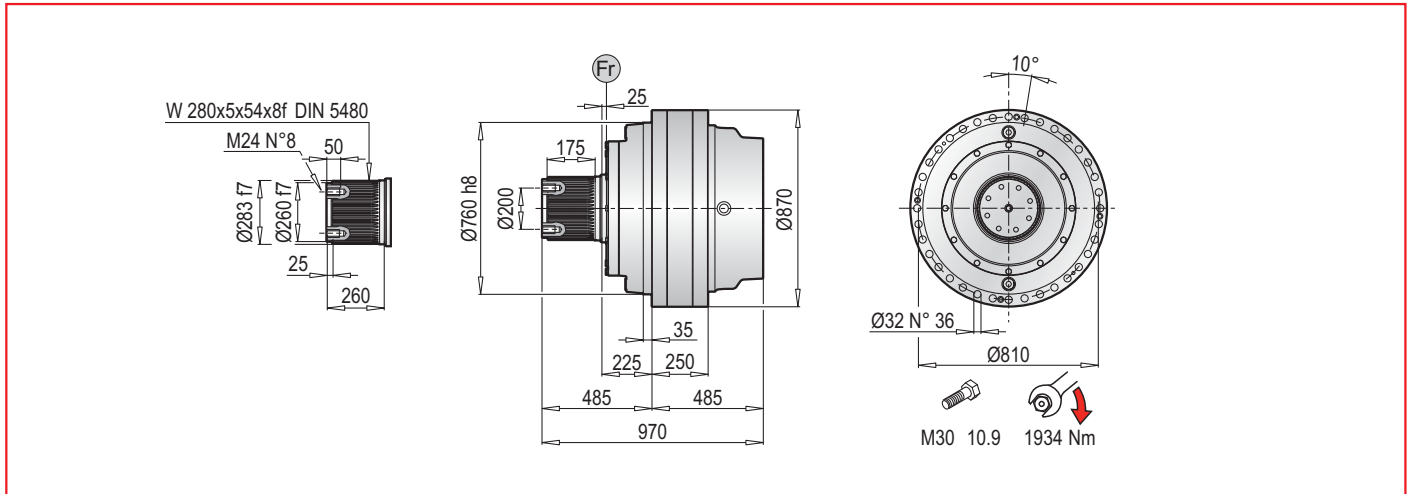

PL 300000 MS - Elektrik Motor Adaptörleri (IEC) / Electric Motor Couplings (IEC) / Anbauvorrichtung Für Elektromotore (IEC) / Predisposizioni Per Motori Elettrici (IEC) / Adaptations Pour Moteurs Electriques (IEC) / Acoplamientos Para Motores Eléctricos (IEC)

PL	IEC 63			IEC 71			IEC 80			IEC 90			IEC 100			IEC 112			IEC 132						
	L _T	Z	ØD	L _T	Z	ØD	L _T	Z	ØD	L _T	Z	ØD	L _T	Z	ØD	L _T	Z	ØD	L _T	Z	ØD				
300001	-	-	-	-	-	-	-	-	-	-	-	-	-	-	-	-	-	-	-	-	-	-	-	-	
300002	-	-	-	-	-	-	-	-	-	-	-	-	-	-	-	-	-	-	-	-	-	-	-	-	
300003	-	-	-	-	-	-	-	-	-	-	-	-	-	-	-	-	-	-	-	-	-	-	-	-	
300004	-	-	-	-	-	-	-	-	-	-	-	-	-	-	-	-	-	-	-	-	-	-	-	-	
300005	1111.5	36	140	1111.5	36	160	1131.5	56	200	1131.5	56	200	1141.5	66	250	1141.5	66	250	1175.5	100	300				

PL	IEC 160			IEC 180			IEC 200			IEC 225			IEC 250			IEC 280					
	L _T	Z	ØD	L _T	Z	ØD	L _T	Z	ØD	L _T	Z	ØD	L _T	Z	ØD	L _T	Z	ØD			
300001	635	-	-	635	-	-	635	-	-	624	-	-	624	-	-	624	-	-			
300002	890	150	-	890	150	-	890	150	-	879	139	450	879	139	550	879	139	550			
300003	1072	-	350	1072	-	350	1072	-	400	1061	-	-	1061	-	-	1061	-	-			
300004	1134	118	-	1134	118	-	1164	148	-	1155	-	-	1164.5	148.5	-	-	-	-			
300005	1214.5	139	-	1214.5	139	-	-	-	-	-	-	-	-	-	-	-	-	-			

PL	IEC ~ Kg												
	63	71	80	90	100	112	132	160	180	200	225	250	280
300001	-	-	-	-	-	-	-	1955	1955	1960	1966	1978	1990
300002	-	-	-	-	-	-	-	2263	2263	2268	2274	2286	2298
300003	-	-	-	-	-	-	-	2437	2437	2442	2468	2460	2472
300004	-	-	-	-	-	-	-	2434	2434	2444	2449	2490	-
300005	2453	2453	2455	2455	2456	2456	2460	2470	2470	-	-	-	-

PL 300000 MS - Giriş Milleri / Input Shafts / Antriebswellen / Alberi Entrata / Arbres D'entree / Ejes De Entrada

PL	EL C 28				EL C 42				EML 42				EML 1"3/8 Z6				EM 65				EM 1"3/8 Z6			
	L _T	Z	L	Ød	L _T	Z	L	Ød	L _T	Z	L	Ød	L _T	Z	L	Ød	L _T	Z	L	Ød	L _T	Z	L	Ød
300003	-	-	-	-	-	-	-	-	-	-	-	-	-	-	-	-	-	-	-	-	-	-	-	-
300004	-	-	-	-	-	-	-	-	-	-	-	-	-	-	-	-	1137.5	121.5	105	65	1137.5	121.5	105	1"3/8
300005	1139.5	64	50	28	1139.5	64	82	42	1169.5	94	82	42	1169.5	94	106	1"3/8	1197	121.5	105	65	1197	121.5	105	1"3/8

PL	EP 65				ET 90				PL	~ Kg							
	L _T	Z	L	Ød	L _T	Z	L	Ød		EL C 28	EL C 42	EML 42	EML 1"3/8 Z6	EM 65	EM 1"3/8 Z6	EP 65	ET 90
300003	-	-	-	-	1093.5	171.5	170	90	300003	-	-	-	-	-	-	-	2440
300004	1169	153	105	65	-	-	-	-	300004	-	-	-	-	2429	2429	2438	-
300005	1228.5	-	-	-	-	-	-	-	300005	2454	2454	2457	2457	2465	2465	2474	-

PL 300000 MS - Sonsuz Dişli Redüktör Adaptörleri (PMRV/PRV) / Worm Gearbox Adaptors (PMRV/PRV) / Anschluss Für Schneckengetriebe (PMRV/PRV) / Predisposizioni Per Riduttori A Vite Senza Fine (PMRV/PRV) / Adaptation Pour Reducteurs A Vis Sans Fin (PMRV/PRV) / Acoplamiento Para Reductores De Tornillo Sin Fin (PMRV/PRV)

PL	PMRV/PRV 050					PMRV/PRV 063					PMRV/PRV 075				
	Lm	l	h	MA	G	Lm	l	h	MA	G	Lm	l	h	MA	G
300004	-					-					-				
300005	1197	50	110	60	80	1206.5	63	113	72	95	1185.5	75	161	86	112.5

PL	PMRV/PRV 090					PMRV/PRV 110					PMRV/PRV 130				
	Lm	l	h	MA	G	Lm	l	h	MA	G	Lm	l	h	MA	G
300004	-					1150	110	237.5	127.5	160	1155.5	130	277.5	147.5	180
300005	1195.5	90	193	103	129.5	1209.5	110	237.5	127.5	160	1215	130	277.5	147.5	180

PL	PMRV/PRV 150				
	Lm	l	h	MA	G
300004	1172	150	320	170	210
300005	1231.5	150	320	170	210

PL	PMRV/PRV ~ Kg						
	050	063	075	090	110	130	150
300004	-	-	-	-	2264	2465	2511
300005	2456	2459.5	2462	2467	2494	2511	2547

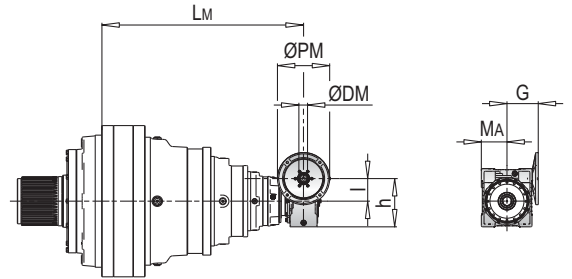

PLB 300000 MS - Elektrik Motor Adaptörleri (IEC) / Electric Motor Couplings (IEC) / Anbauvorrichtung Für Elektromotore (IEC) / Predisposizioni Per Motori Elettrici (IEC) / Adaptations Pour Moteurs Electriques (IEC) / Acoplamientos Para Motores Eléctricos (IEC)

PLB	IEC 80				IEC 90				IEC 100				IEC 112				IEC 132			
	A	Lt	Z	ØD	A	Lt	Z	ØD	A	Lt	Z	ØD	A	Lt	Z	ØD	A	Lt	Z	ØD
300004	-				-				-				-				-			
300005	1138	296	56	200	1138	296	56	200	1138	306	66	250	1138	306	66	250	1138	340	100	300

PLB	IEC 160				IEC 180				IEC 200				IEC 225				IEC 250			
	A	Lt	Z	ØD	A	Lt	Z	ØD	A	Lt	Z	ØD	A	Lt	Z	ØD	A	Lt	Z	ØD
300004	1028	433	118	350	1028	433	118	350	1028	463	148	400	1028	451	139	450	1028	463.5	148.5	550
300005	1138	379	139	350	1138	379	139	350	-	-	-	-	-	-	-	-	-	-	-	-

PLB	IEC ~ Kg									
	80	90	100	112	132	160	180	200	225	250
300004	-	-	-	-	-	2525	2525	2540	2545	2586
300005	2535	2535	2536	2536	2540	2550	2550	-	-	-

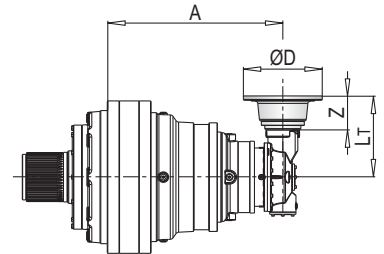

PLB 300000 MS - Giriş Milleri / Input Shafts / Antriebswellen / Alberi Entrata / Arbres D'entree / Ejes De Entrada

PLB	EL C 28					EL C 42					EML 42					EML 1"3/8 Z6					EM 65				
	A	Lt	Z	L	Ød	A	Lt	Z	L	Ød	A	Lt	Z	L	Ød	A	Lt	Z	L	Ød	A	Lt	Z	L	Ød
300004	-					-					-					-					1028	436.5	121.5	105	65
300005	1138	304	64	50	28	1138	304	64	82	42	1138	334	94	82	42	1138	334	106	82	1"3/8	1138	361.5	121.5	105	65

PLB	EM 1"3/8 Z6					EP 65				
	A	Lt	Z	L	Ød	A	Lt	Z	L	Ød
300004	1028	436.5	121.5	105	1"3/8	1028	468	153	105	65
300005	1138	361.5	121.5	105	1"3/8	1138	393	153	105	65

PLB	~ Kg						
	EL C 28	EL C 42	EML 42	EML 1"3/8 Z6	EM 65	EM 1"3/8 Z6	EP 65
300004	-	-	-	-	2525	2525	2534
300005	2534	2534	2537	2537	2545	2545	2554

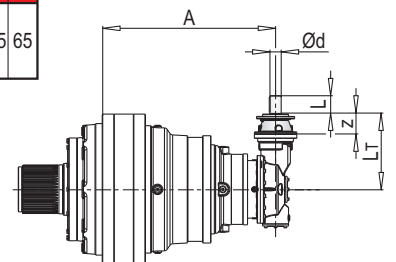

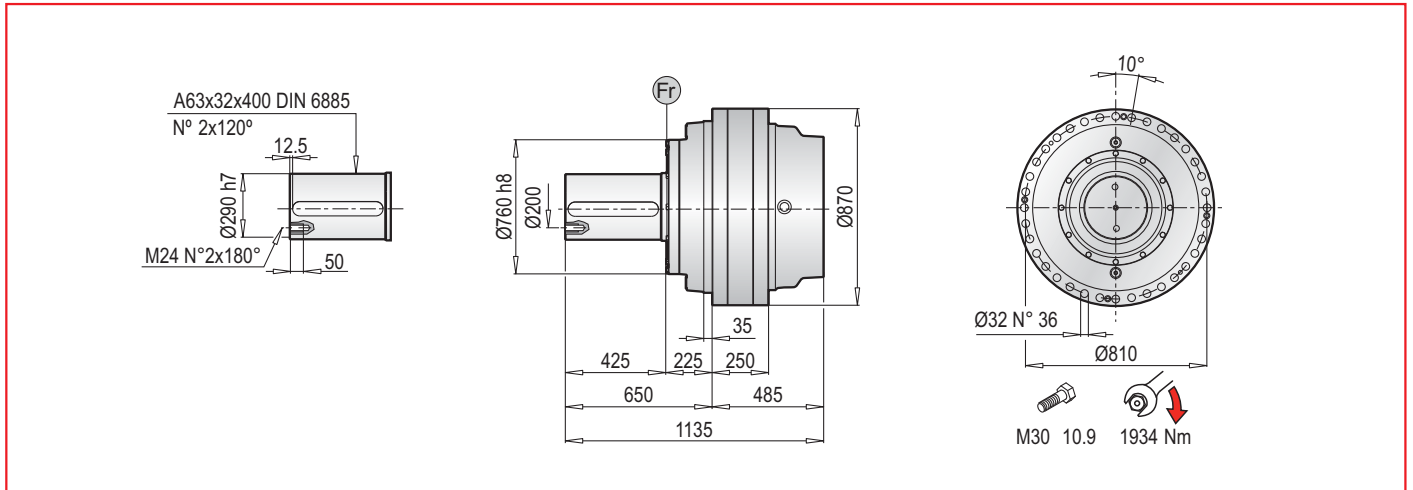

PL 300000 MC - Elektrik Motor Adaptörleri (IEC) / Electric Motor Couplings (IEC) / Anbauvorrichtung Für Elektromotore (IEC) / Predisposizioni Per Motori Elettrici (IEC) / Adaptations Pour Moteurs Electriques (IEC) / Acoplamientos Para Motores Eléctricos (IEC)

PL	IEC 63			IEC 71			IEC 80			IEC 90			IEC 100			IEC 112			IEC 132			
	L _T	Z	ØD	L _T	Z	ØD	L _T	Z	ØD	L _T	Z	ØD	L _T	Z	ØD	L _T	Z	ØD	L _T	Z	ØD	
300001	-	-	-	-	-	-	-	-	-	-	-	-	-	-	-	-	-	-	-	-	-	-
300002	-	-	-	-	-	-	-	-	-	-	-	-	-	-	-	-	-	-	-	-	-	-
300003	-	-	-	-	-	-	-	-	-	-	-	-	-	-	-	-	-	-	-	-	-	-
300004	-	-	-	-	-	-	-	-	-	-	-	-	-	-	-	-	-	-	-	-	-	-
300005	1111.5	36	140	1111.5	36	160	1131.5	56	200	1131.5	56	200	1141.5	66	250	1141.5	66	250	1175.5	100	300	

PL	IEC 160			IEC 180			IEC 200			IEC 225			IEC 250			IEC 280						
	L _T	Z	ØD	L _T	Z	ØD	L _T	Z	ØD	L _T	Z	ØD	L _T	Z	ØD	L _T	Z	ØD				
300001	635	-	-	635	-	-	635	-	-	624	-	-	624	-	-	624	-	-	624	-	-	624
300002	890	150	-	890	150	-	890	150	-	879	139	450	879	139	550	879	139	550	879	139	550	879
300003	1072	-	350	1072	-	350	1072	-	400	1061	-	-	1061	-	-	1061	-	-	1061	-	-	1061
300004	1134	118	-	1134	118	-	1164	148	-	1155	-	-	1164.5	148.5	-	-	-	-	-	-	-	-
300005	1214.5	139	-	1214.5	139	-	-	-	-	-	-	-	-	-	-	-	-	-	-	-	-	-

PL	IEC ~ Kg												
	63	71	80	90	100	112	132	160	180	200	225	250	280
300001	-	-	-	-	-	-	-	1955	1955	1960	1966	1978	1990
300002	-	-	-	-	-	-	-	2263	2263	2268	2274	2286	2298
300003	-	-	-	-	-	-	-	2437	2437	2442	2468	2460	2472
300004	-	-	-	-	-	-	-	2434	2434	2444	2449	2490	-
300005	2453	2453	2455	2455	2456	2456	2460	2470	2470	-	-	-	-

PL 300000 MC - Giriş Milleri / Input Shafts / Antriebswellen / Alberi Entrata / Arbres D'entree / Ejes De Entrada

PL	EL C 28				EL C 42				EML 42				EML 1"3/8 Z6				EM 65				EM 1"3/8 Z6			
	L _T	Z	L	Ød	L _T	Z	L	Ød	L _T	Z	L	Ød	L _T	Z	L	Ød	L _T	Z	L	Ød	L _T	Z	L	Ød
300003	-	-	-	-	-	-	-	-	-	-	-	-	-	-	-	-	-	-	-	-	-	-	-	-
300004	-	-	-	-	-	-	-	-	-	-	-	-	-	-	-	-	1137.5	121.5	105	65	1137.5	121.5	105	1"3/8
300005	1139.5	64	50	28	1139.5	64	82	42	1169.5	94	82	42	1169.5	94	106	1"3/8	1197	121.5	105	65	1197	121.5	105	1"3/8

PL	EP 65				ET 90				PL	~ Kg							
	L _T	Z	L	Ød	L _T	Z	L	Ød		EL C 28	EL C 42	EML 42	EML 1"3/8 Z6	EM 65	EM 1"3/8 Z6	EP 65	ET 90
300003	-	-	-	-	1093.5	171.5	170	90	300003	-	-	-	-	-	-	-	2440
300004	1169	153	105	65	-	-	-	-	300004	-	-	-	-	2429	2429	2438	-
300005	1228.5	-	-	-	-	-	-	-	300005	2454	2454	2457	2457	2465	2465	2474	-

PL 300000 MC - Sonsuz Dişli Redüktör Adaptörleri (PMRV/PRV) / Worm Gearbox Adaptors (PMRV/PRV) / Anschluss Für Schneckengetriebe (PMRV/PRV) / Predisposizioni Per Riduttori A Vite Senza Fine (PMRV/PRV) / Adaptation Pour Reducteurs A Vis Sans Fin (PMRV/PRV) / Acoplamiento Para Reductores De Tornillo Sin Fin (PMRV/PRV)

PL	PMRV/PRV 050					PMRV/PRV 063					PMRV/PRV 075				
	Lm	I	h	MA	G	Lm	I	h	MA	G	Lm	I	h	MA	G
300004	-					-					-				
300005	1197	50	110	60	80	1206.5	63	113	72	95	1185.5	75	161	86	112.5

PL	PMRV/PRV 090					PMRV/PRV 110					PMRV/PRV 130				
	Lm	I	h	MA	G	Lm	I	h	MA	G	Lm	I	h	MA	G
300004	-					1150	110	237.5	127.5	160	1155.5	130	277.5	147.5	180
300005	1195.5	90	193	103	129.5	1209.5	110	237.5	127.5	160	1215	130	277.5	147.5	180

PL	PMRV/PRV 150				
	Lm	I	h	MA	G
300004	1172	150	320	170	210
300005	1231.5	150	320	170	210

PL	PMRV/PRV ~ Kg						
	050	063	075	090	110	130	150
300004	-	-	-	-	2264	2465	2511
300005	2456	2459.5	2462	2467	2494	2511	2547

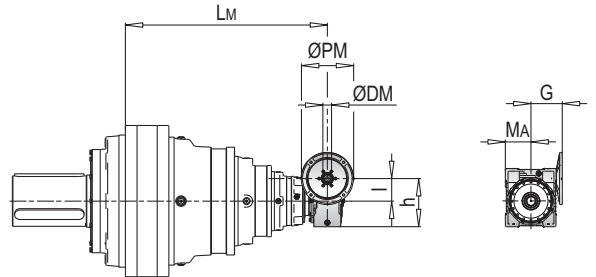

PLB 300000 MC - Elektrik Motor Adaptörleri (IEC) / Electric Motor Couplings (IEC) / Anbauvorrichtung Für Elektromotore (IEC) / Predisposizioni Per Motori Elettrici (IEC) / Adaptations Pour Moteurs Electriques (IEC) / Acoplamientos Para Motores Eléctricos (IEC)

PLB	IEC 80				IEC 90				IEC 100				IEC 112				IEC 132			
	A	LT	Z	ØD	A	LT	Z	ØD	A	LT	Z	ØD	A	LT	Z	ØD	A	LT	Z	ØD
300004	-				-				-				-				-			
300005	1138	296	56	200	1138	296	56	200	1138	306	66	250	1138	306	66	250	1138	340	100	300

PLB	IEC 160				IEC 180				IEC 200				IEC 225				IEC 250			
	A	LT	Z	ØD	A	LT	Z	ØD	A	LT	Z	ØD	A	LT	Z	ØD	A	LT	Z	ØD
300004	1028	433	118	350	1028	433	118	350	1028	463	148	400	1028	451	139	450	1028	463.5	148.5	550
300005	1138	379	139	350	1138	379	139	350	-	-	-	-	-	-	-	-	-	-	-	-

PLB	IEC ~ Kg									
	80	90	100	112	132	160	180	200	225	250
300004	-	-	-	-	-	2525	2525	2540	2545	2586
300005	2535	2535	2536	2536	2540	2550	2550	-	-	-

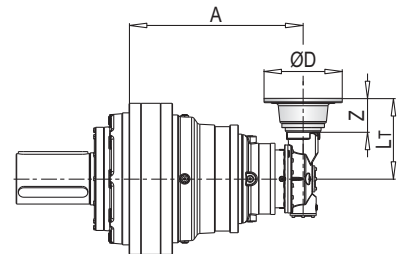

PLB 300000 MC - Giriş Milleri / Input Shafts / Antriebswellen / Alberi Entrata / Arbres D'entree / Ejes De Entrada

PLB	EL C 28					EL C 42					EML 42					EML 1"3/8 Z6					EM 65				
	A	LT	Z	L	Ød	A	LT	Z	L	Ød	A	LT	Z	L	Ød	A	LT	Z	L	Ød	A	LT	Z	L	Ød
300004	-					-					-					-					1028	436.5	121.5	105	65
300005	1138	304	64	50	28	1138	304	64	82	42	1138	334	94	82	42	1138	334	106	82	1"3/8	1138	361.5	121.5	105	65

PLB	EM 1"3/8 Z6					EP 65				
	A	LT	Z	L	Ød	A	LT	Z	L	Ød
300004	1028	436.5	121.5	105	1"3/8	1028	468	153	105	65
300005	1138	361.5	121.5	105	1"3/8	1138	393	153	105	65

PLB	~ Kg						
	EL C 28	EL C 42	EML 42	EML 1"3/8 Z6	EM 65	EM 1"3/8 Z6	EP 65
300004	-	-	-	-	2525	2525	2534
300005	2534	2534	2537	2537	2545	2545	2554

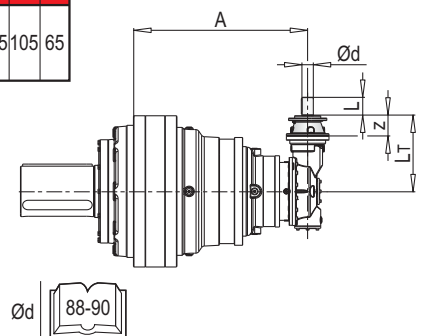

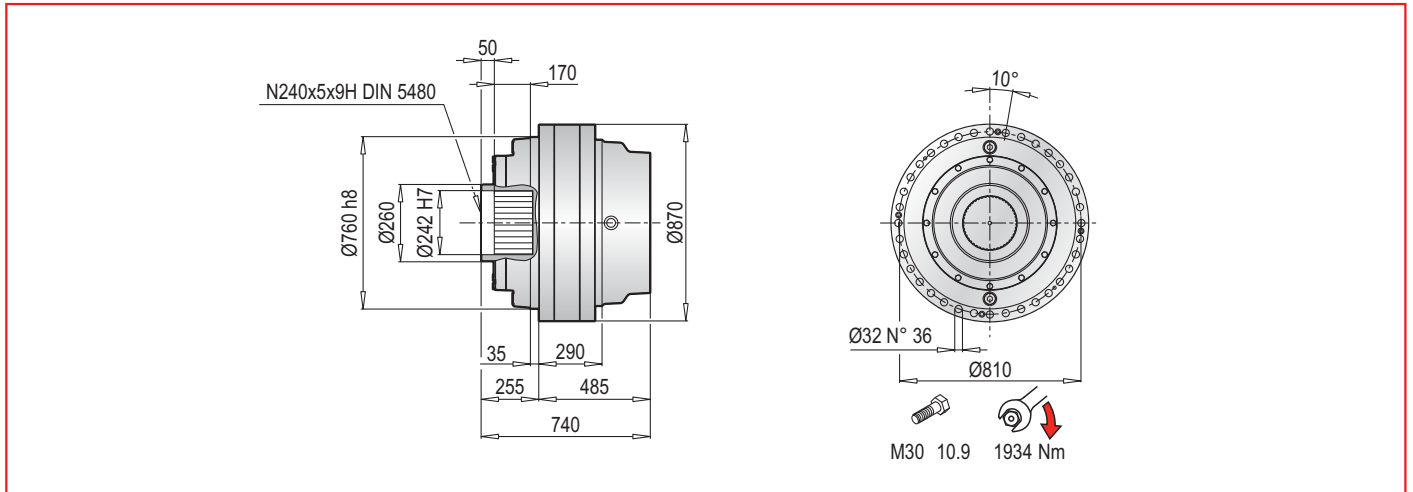

PL 30000 F - Elektrik Motor Adaptörleri (IEC) / Electric Motor Couplings (IEC) / Anbauvorrichtung Für Elektromotore (IEC) / Predisposizioni Per Motori Elettrici (IEC) / Adaptations Pour Moteurs Electriques (IEC) / Acoplamientos Para Motores Eléctricos (IEC)

PL	IEC 63			IEC 71			IEC 80			IEC 90			IEC 100			IEC 112			IEC 132		
	L _T	Z	ØD	L _T	Z	ØD	L _T	Z	ØD	L _T	Z	ØD	L _T	Z	ØD	L _T	Z	ØD	L _T	Z	ØD
300001	-	-	-	-	-	-	-	-	-	-	-	-	-	-	-	-	-	-	-	-	-
300002	-	-	-	-	-	-	-	-	-	-	-	-	-	-	-	-	-	-	-	-	-
300003	-	-	-	-	-	-	-	-	-	-	-	-	-	-	-	-	-	-	-	-	-
300004	-	-	-	-	-	-	-	-	-	-	-	-	-	-	-	-	-	-	-	-	-
300005	1111.5	36	140	1111.5	36	160	1131.5	56	200	1131.5	56	200	1141.5	66	250	1141.5	66	250	1175.5	100	300

PL	IEC 160			IEC 180			IEC 200			IEC 225			IEC 250			IEC 280		
	L _T	Z	ØD	L _T	Z	ØD	L _T	Z	ØD	L _T	Z	ØD	L _T	Z	ØD	L _T	Z	ØD
300001	635	-	-	635	-	-	635	-	-	624	-	-	624	-	-	624	-	-
300002	890	150	-	890	150	-	890	150	-	879	139	450	879	139	550	879	139	550
300003	1072	-	350	1072	-	350	1072	-	400	1061	-	-	1061	-	-	1061	-	-
300004	1134	118	-	1134	118	-	1164	148	-	1155	-	-	1164.5	148.5	-	-	-	-
300005	1214.5	139	-	1214.5	139	-	-	-	-	-	-	-	-	-	-	-	-	-

PL	IEC ~ Kg												
	63	71	80	90	100	112	132	160	180	200	225	250	280
300001	-	-	-	-	-	-	-	1805	1805	1810	1816	1828	1840
300002	-	-	-	-	-	-	-	2113	2113	2118	2124	2136	2148
300003	-	-	-	-	-	-	-	2287	2287	2292	2298	2310	2322
300004	-	-	-	-	-	-	-	2284	2284	2294	2318	2340	-
300005	2303	2303	2305	2305	2306	2306	2310	2320	2320	-	-	-	-

PL 30000 F - Giriş Milleri / Input Shafts / Antriebswellen / Alberi Entrata / Arbres D'entree / Ejes De Entrada

PL	EL C 28				EL C 42				EML 42				EML 1"3/8 Z6				EM 65				EM 1"3/8 Z6			
	L _T	Z	L	Ød	L _T	Z	L	Ød	L _T	Z	L	Ød	L _T	Z	L	Ød	L _T	Z	L	Ød	L _T	Z	L	Ød
300003	-	-	-	-	-	-	-	-	-	-	-	-	-	-	-	-	-	-	-	-	-	-	-	-
300004	-	-	-	-	-	-	-	-	-	-	-	-	-	-	-	-	1137.5	121.5	105	65	1137.5	121.5	105	1"3/8
300005	1139.5	64	50	28	1139.5	64	82	42	1169.5	94	82	42	1169.5	94	106	1"3/8	1197	121.5	105	65	1197	121.5	105	1"3/8

PL	EP 65				ET 90				PL	~ Kg							
	L _T	Z	L	Ød	L _T	Z	L	Ød		EL C 28	EL C 42	EML 42	EML 1"3/8 Z6	EM 65	EM 1"3/8 Z6	EP 65	ET 90
300003	-	-	-	-	1093.5	171.5	170	90	30003	-	-	-	-	-	-	-	2290
300004	1169	153	105	65	-	-	-	-	30004	-	-	-	-	2279	2279	2288	-
300005	1228.5	-	-	-	-	-	-	-	30005	2304	2304	2307	2307	2315	2465	2324	-

PL 300000 F - Sansuz Dişli Redüktör Adaptörleri (PMRV/PRV) / Worm Gearbox Adaptors (PMRV/PRV) / Anschluss Für Schneckengetriebe (PMRV/PRV) / Predisposizioni Per Riduttori A Vite Senza Fine (PMRV/PRV) / Adaptation Pour Reducteurs A Vis Sans Fin (PMRV/PRV) / Acoplamiento Para Reductores De Tornillo Sin Fin (PMRV/PRV)

PL	PMRV/PRV 050					PMRV/PRV 063					PMRV/PRV 075				
	Lm	l	h	MA	G	Lm	l	h	MA	G	Lm	l	h	MA	G
300004	-					-					-				
300005	1197	50	110	60	80	1206.5	63	113	72	95	1185.5	75	161	86	112.5

PL	PMRV/PRV 090					PMRV/PRV 110					PMRV/PRV 130				
	Lm	l	h	MA	G	Lm	l	h	MA	G	Lm	l	h	MA	G
300004	-					1150	110	237.5	127.5	160	1155.5	130	277.5	147.5	180
300005	1195.5	90	193	103	129.5	1209.5	110	237.5	127.5	160	1215	130	277.5	147.5	180

PL	PMRV/PRV 150				
	Lm	l	h	MA	G
300004	1172	150	320	170	210
300005	1231.5	150	320	170	210

PL	PMRV/PRV ~ Kg						
	050	063	075	090	110	130	150
300004	-	-	-	-	2114	2315	2361
300005	2306	2310	2312	2317	2344	2361	2397

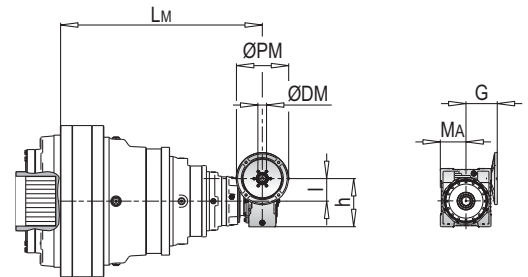

PLB 300000 F - Elektrik Motor Adaptörleri (IEC) / Electric Motor Couplings (IEC) / Anbauvorrichtung Für Elektromotore (IEC) / Predisposizioni Per Motori Elettrici (IEC) / Adaptations Pour Moteurs Electriques (IEC) / Acoplamientos Para Motores Eléctricos (IEC)

PLB	IEC 80				IEC 90				IEC 100				IEC 112				IEC 132			
	A	Lt	Z	ØD	A	Lt	Z	ØD	A	Lt	Z	ØD	A	Lt	Z	ØD	A	Lt	Z	ØD
300004	-				-				-				-				-			
300005	1138	296	56	200	1138	296	56	200	1138	306	66	250	1138	306	66	250	1138	340	100	300

PLB	IEC 160				IEC 180				IEC 200				IEC 225				IEC 250			
	A	Lt	Z	ØD	A	Lt	Z	ØD	A	Lt	Z	ØD	A	Lt	Z	ØD	A	Lt	Z	ØD
300004	1028	433	118	350	1028	433	118	350	1028	463	148	400	1028	451	139	450	1028	463.5	148.5	550
300005	1138	379	139	350	1138	379	139	350	-	-	-	-	-	-	-	-	-	-	-	-

PLB	IEC ~ Kg									
	80	90	100	112	132	160	180	200	225	250
300004	-	-	-	-	-	2375	2375	2390	2395	2436
300005	2385	2385	2386	2386	2390	2400	2400	-	-	-

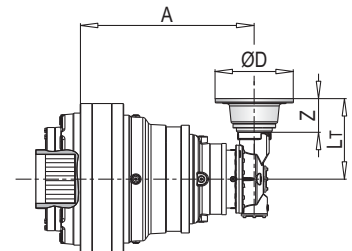

PLB 300000 F - Giriş Milleri / Input Shafts / Antriebswellen / Alberi Entrata / Arbres D'entree / Ejes De Entrada

PLB	EL C 28					EL C 42					EML 42					EML 1"3/8 Z6					EM 65				
	A	Lt	Z	L	Ød	A	Lt	Z	L	Ød	A	Lt	Z	L	Ød	A	Lt	Z	L	Ød	A	Lt	Z	L	Ød
300004	-					-					-					-					1028	436.5	121.5	105	65
300005	1138	304	64	50	28	1138	304	64	82	42	1138	334	94	82	42	1138	334	106	82	1"3/8	1138	361.5	121.5	105	65

PLB	EM 1"3/8 Z6					EP 65				
	A	Lt	Z	L	Ød	A	Lt	Z	L	Ød
300004	1028	436.5	121.5	105	1"3/8	1028	468	153	105	65
300005	1138	361.5	121.5	105	1"3/8	1138	393	153	105	65

PLB	~ Kg						
	EL C 28	EL C 42	EML 42	EML 1"3/8 Z6	EM 65	EM 1"3/8 Z6	EP 65
300004	-	-	-	-	2375	2375	2384
300005	2384	2384	2387	2387	2395	2395	2404

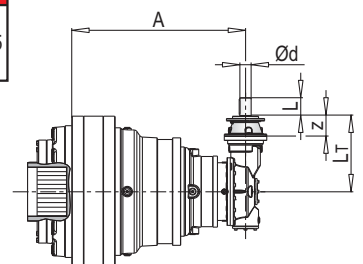

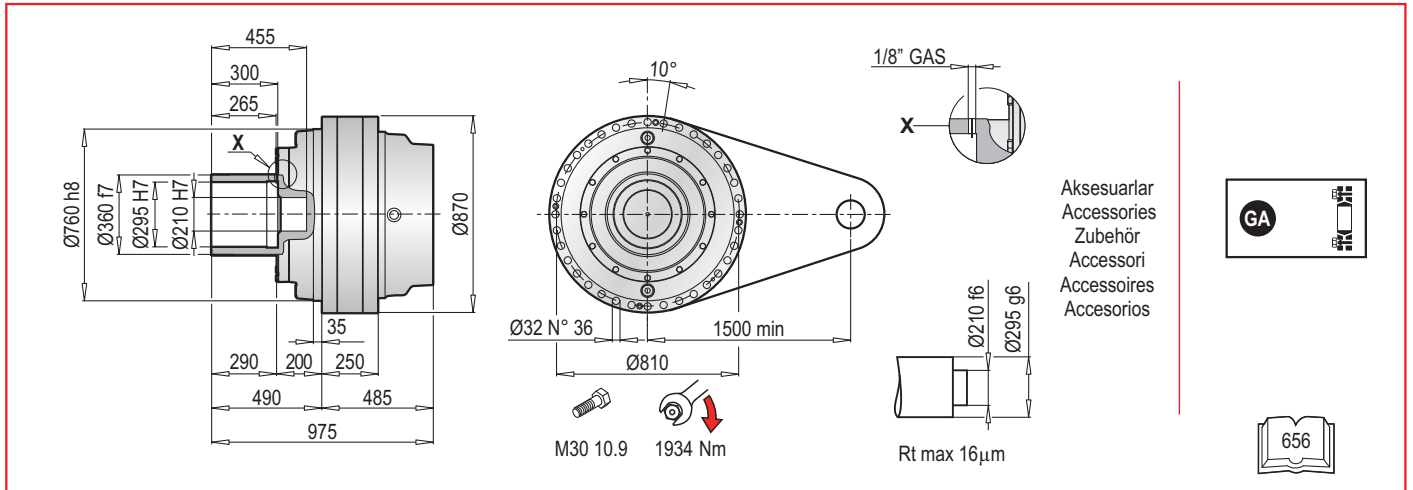

PL 300000 FS - Elektrik Motor Adaptörleri (IEC) / Electric Motor Couplings (IEC) / Anbauvorrichtung Für Elektromotore (IEC) / Predisposizioni Per Motori Elettrici (IEC) / Adaptations Pour Moteurs Electriques (IEC) / Acoplamientos Para Motores Eléctricos (IEC)

PL	IEC 63			IEC 71			IEC 80			IEC 90			IEC 100			IEC 112			IEC 132			
	L _T	Z	ØD	L _T	Z	ØD	L _T	Z	ØD	L _T	Z	ØD	L _T	Z	ØD	L _T	Z	ØD	L _T	Z	ØD	
300001	-	-	-	-	-	-	-	-	-	-	-	-	-	-	-	-	-	-	-	-	-	-
300002	-	-	-	-	-	-	-	-	-	-	-	-	-	-	-	-	-	-	-	-	-	-
300003	-	-	-	-	-	-	-	-	-	-	-	-	-	-	-	-	-	-	-	-	-	-
300004	-	-	-	-	-	-	-	-	-	-	-	-	-	-	-	-	-	-	-	-	-	-
300005	1111.5	36	140	1111.5	36	160	1131.5	56	200	1131.5	56	200	1141.5	66	250	1141.5	66	250	1175.5	100	300	

PL	IEC 160			IEC 180			IEC 200			IEC 225			IEC 250			IEC 280			
	L _T	Z	ØD	L _T	Z	ØD	L _T	Z	ØD	L _T	Z	ØD	L _T	Z	ØD	L _T	Z	ØD	
300001	635	-	-	635	-	-	635	-	-	624	-	-	624	-	-	624	-	-	
300002	890	150	-	890	150	-	890	150	-	879	139	450	879	139	550	879	139	550	
300003	1072	-	350	1072	-	350	1072	-	400	1061	-	-	1061	-	-	1061	-	-	
300004	1134	118	-	1134	118	-	1164	148	-	1155	-	-	1164.5	148.5	-	-	-	-	
300005	1214.5	139	-	1214.5	139	-	-	-	-	-	-	-	-	-	-	-	-	-	

PL	IEC ~ Kg												
	63	71	80	90	100	112	132	160	180	200	225	250	280
300001	-	-	-	-	-	-	-	1913	1913	1918	1924	1936	1948
300002	-	-	-	-	-	-	-	2221	2221	2226	2232	2244	2256
300003	-	-	-	-	-	-	-	2395	2395	2400	2426	2418	2430
300004	-	-	-	-	-	-	-	2392	2392	2402	2407	2448	-
300005	2411	2411	2413	2413	2414	2414	2418	2428	2428	-	-	-	-

PL 300000 FS - Giriş Milleri / Input Shafts / Antriebswellen / Alberi Entrata / Arbres D'entree / Ejes De Entrada

PL	EL C 28				EL C 42				EML 42				EML 1"3/8 Z6				EM 65				EM 1"3/8 Z6				
	L _T	Z	L	Ød	L _T	Z	L	Ød	L _T	Z	L	Ød	L _T	Z	L	Ød	L _T	Z	L	Ød	L _T	Z	L	Ød	
300003	-	-	-	-	-	-	-	-	-	-	-	-	-	-	-	-	-	-	-	-	-	-	-	-	-
300004	-	-	-	-	-	-	-	-	-	-	-	-	-	-	-	-	1137.5	121.5	105	65	1137.5	121.5	105	1"3/8	
300005	1139.5	64	50	28	1139.5	64	82	42	1169.5	94	82	42	1169.5	94	106	1"3/8	1197	121.5	105	65	1197	121.5	105	1"3/8	

PL	EP 65				ET 90			
	L _T	Z	L	Ød	L _T	Z	L	Ød
300003	-	-	-	-	1093.5	171.5	170	90
300004	1169	153	105	65	-	-	-	-
300005	1228.5	-	-	-	-	-	-	-

PL	~ Kg							
	EL C 28	EL C 42	EML 42	EML 1"3/8 Z6	EM 65	EM 1"3/8 Z6	EP 65	ET 90
300003	-	-	-	-	-	-	-	2398
300004	-	-	-	-	2387	2387	2396	-
300005	2412	2412	2415	2415	2423	2423	2432	-

PL 30000 FS - Sonsuz Dişli Redüktör Adaptörleri (PMRV/PRV) / Worm Gearbox Adaptors (PMRV/PRV) / Anschluss Für Schneckengetriebe (PMRV/PRV) / Predisposizioni Per Riduttori A Vite Senza Fine (PMRV/PRV) / Adaptation Pour Reducteurs A Vis Sans Fin (PMRV/PRV) / Acoplamiento Para Reductores De Tornillo Sin Fin (PMRV/PRV)

PL	PMRV/PRV 050					PMRV/PRV 063					PMRV/PRV 075				
	Lm	l	h	MA	G	Lm	l	h	MA	G	Lm	l	h	MA	G
300004	-					-					-				
300005	1197	50	110	60	80	1206.5	63	113	72	95	1185.5	75	161	86	112.5

PL	PMRV/PRV 090					PMRV/PRV 110					PMRV/PRV 130				
	Lm	l	h	MA	G	Lm	l	h	MA	G	Lm	l	h	MA	G
300004	-					1150	-				1155.5	-			
300005	1195.5	90	193	103	129.5	1209.5	110	237.5	127.5	160	1215	130	277.5	147.5	180

PL	PMRV/PRV 150				
	Lm	l	h	MA	G
300004	1172	-			
300005	1231.5	150	320	170	210

PL	PMRV/PRV ~ Kg						
	050	063	075	090	110	130	150
300004	-	-	-	-	2222	2423	2469
300005	2414	2418	2420	2425	2452	2469	2505

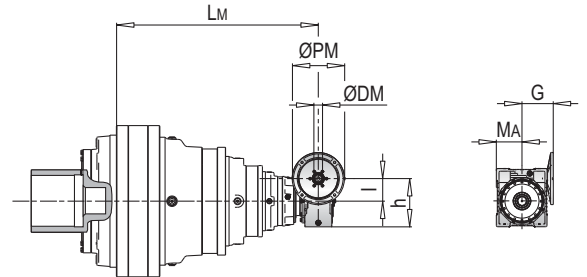

PLB 30000 FS - Elektrik Motor Adaptörleri (IEC) / Electric Motor Couplings (IEC) / Anbauvorrichtung Für Elektromotore (IEC) / Predisposizioni Per Motori Elettrici (IEC) / Adaptations Pour Moteurs Electriques (IEC) / Acoplamientos Para Motores Eléctricos (IEC)

PLB	IEC 80				IEC 90				IEC 100				IEC 112				IEC 132			
	A	LT	Z	ØD	A	LT	Z	ØD	A	LT	Z	ØD	A	LT	Z	ØD	A	LT	Z	ØD
300004	-				-				-				-				-			
300005	1138	296	56	200	1138	296	56	200	1138	306	66	250	1138	306	66	250	1138	340	100	300

PLB	IEC 160				IEC 180				IEC 200				IEC 225				IEC 250			
	A	LT	Z	ØD	A	LT	Z	ØD	A	LT	Z	ØD	A	LT	Z	ØD	A	LT	Z	ØD
300004	1028	433	118	350	1028	433	118	350	1028	463	148	400	1028	451	139	450	1028	463.5	148.5	550
300005	1138	379	139		1138	379	139		-	-	-	-	-	-	-	-	-	-	-	-

PLB	IEC ~ Kg									
	80	90	100	112	132	160	180	200	225	250
300004	-	-	-	-	-	2483	2483	2498	2503	2544
300005	2535	2535	2536	2536	2540	2508	2508	-	-	-

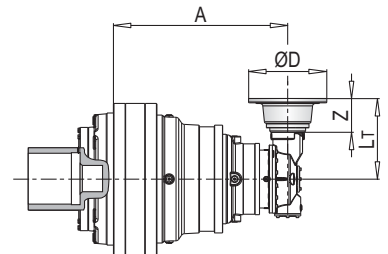

PLB 30000 FS - Giriş Milleri / Input Shafts / Antriebswellen / Alberi Entrata / Arbres D'entree / Ejes De Entrada

PLB	EL C 28					EL C 42					EML 42					EML 1"3/8 Z6					EM 65				
	A	LT	Z	L	Ød	A	LT	Z	L	Ød	A	LT	Z	L	Ød	A	LT	Z	L	Ød	A	LT	Z	L	Ød
300004	-					-					-					-					1028	436.5	-		
300005	1138	304	64	50	28	1138	304	64	82	42	1138	334	94	82	42	1138	334	106	82	1"3/8	1138	361.5	121.5	105	65

PLB	EM 1"3/8 Z6					EP 65				
	A	LT	Z	L	Ød	A	LT	Z	L	Ød
300004	1028	436.5	-			1028	468	-		
300005	1138	361.5	121.5	105	1"3/8	1138	393	153	105	65

PLB	~ Kg						
	EL C 28	EL C 42	EML 42	EML 1"3/8 Z6	EM 65	EM 1"3/8 Z6	EP 65
300004	-	-	-	-	2483	2483	2492
300005	2492	2492	2495	2495	2503	2503	2512

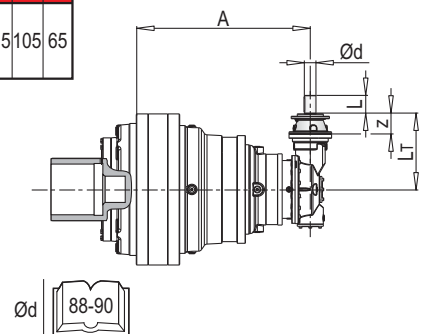

TR

RADYAL YÜKLER (Fr)

Aşağıdaki grafikler istenilen n_2xh değerinin elde edilmesi için gerekli olan radyal yükleri ve K faktörlerini göstermektedir.

EN

RADIAL LOADS (Fr)

The following curves show the radial loads and the K factors to obtain the required n_2xh value.

DE

RADIALLAST (Fr)

In den nachstehenden Diagrammen ist die Radiallast und der Koeffizient K dargestellt und kann mit dem gewünschten Wert n_2xh verglichen werden.

IT

CARICHI RADIALI (Fr)

Nei diagrammi seguenti sono riportati i carichi radiali e i coefficienti K per rapportarli al valore n_2xh desiderato.

FR

CHARGES RADIALES (Fr)

Dans les diagrammes suivants sont indiqués les charges radiales et les facteurs K de façon à obtenir la valeur n_2xh désirée.

ES

CARGAS RADIALES (Fr)

En los siguientes diagramas se indican las cargas radiales y los coeficientes K para obtener el valor requerido n_2xh .

M

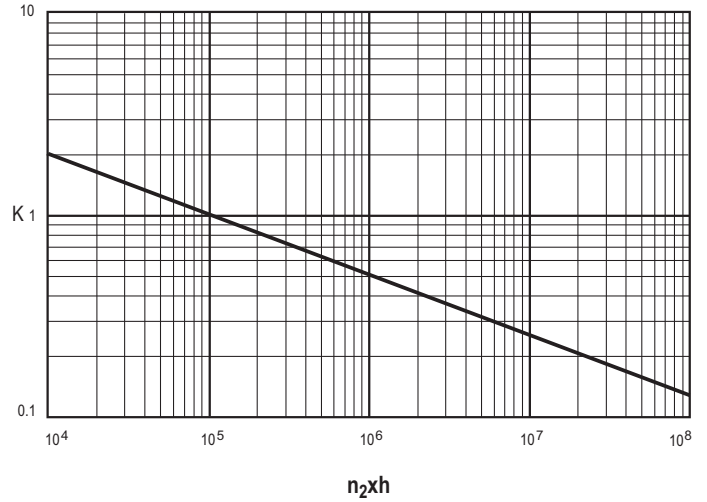
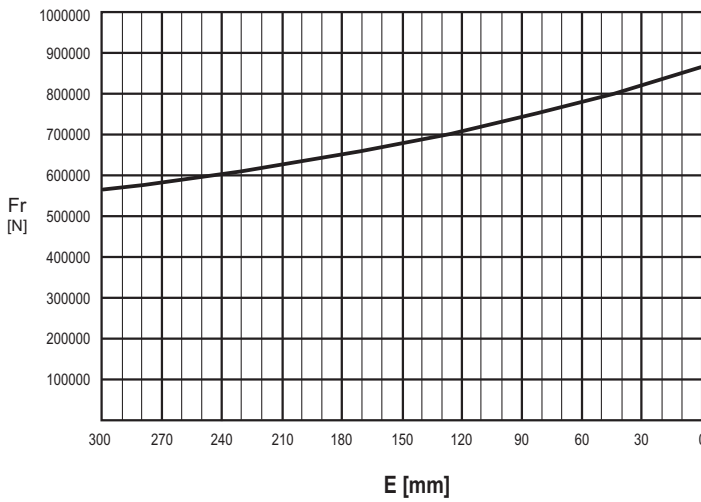

	n_2xh				
	10^5	10^4	10^6	10^7	10^8
M	Fr				Fr • K

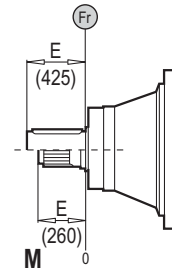

TR

EKSENEL YÜKLER (Fa)

Tabloda yer alan eksenel yük değerleri, çıkış tipine ve uygulamanın yük yönüne göre değişir.

EN

AXIAL LOADS (Fa)

The values of the axial loads in the table refer to the output versions and load direction of application.

DE

AXIALLAST (Fa)

Die dargestellten Werte der Axiallast basieren auf der Version und der applizierten Lastrichtung.

IT

CARICHI ASSIALI (Fa)

I valori dei carichi assiali indicati in tabella sono riferiti alle versioni e alla direzione di applicazione del carico.

FR

CHARGES AXIALES (Fa)

Les valeurs des charges axiales indiquées dans le tableau se réfèrent aux versions et à la direction d'application de la charge.

ES

CARGAS AXIALES (Fa)

Los valores de las cargas axiales indicados en la tabla se refieren a las versiones y a la dirección de aplicación de la carga.

Fa [N]	M	
	240000	←
160500	→	

