

BRUSHLESS-TECH GEARBOXES

Flanged for Servomotors
METRIC EDITION 2025

ITALIAN MADE
PRODUCTS

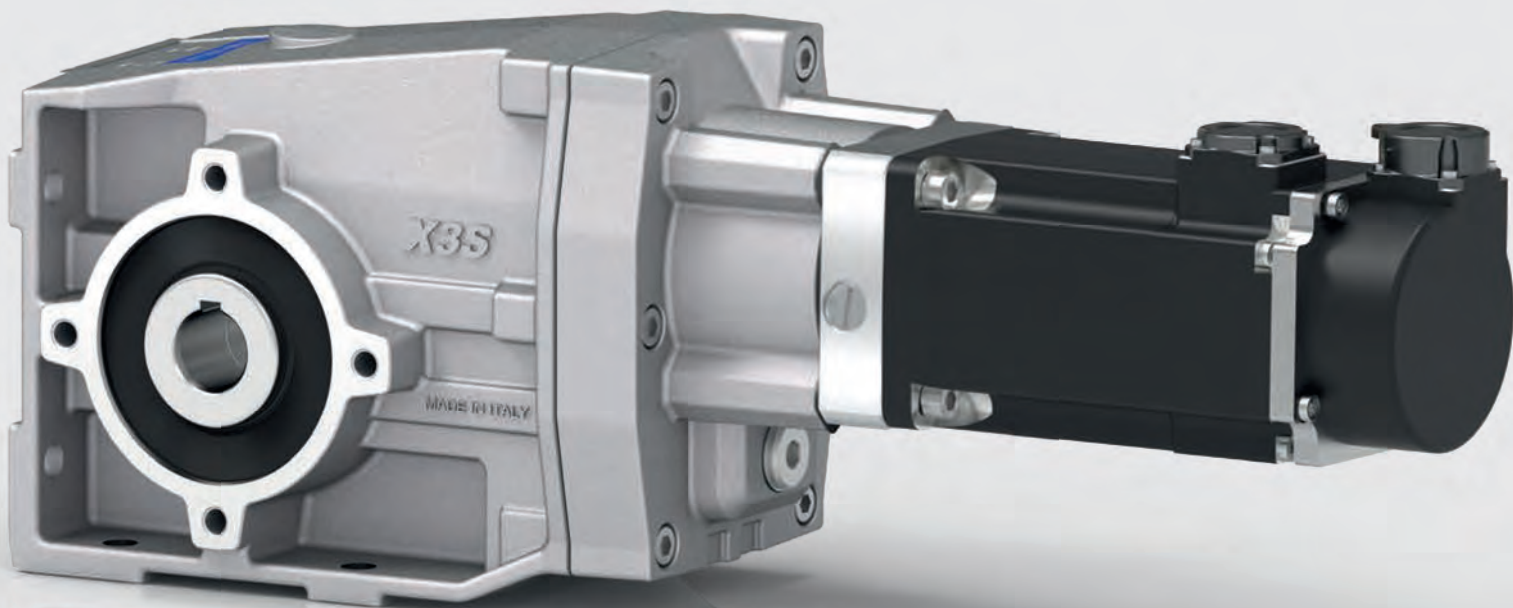

***abaroa*drive**

HIGH EFFICIENCY GEARBOXES

UNIQUE FEATURES

Special input shaft design with internal seal for Brushless applications.

Design speciale dell'albero di entrata con guarnizione interna per applicazioni Brushless.

1 Quality oil seals.
Anelli di tenuta di qualità.

2 All grounded gears.
Tutti gli ingranaggi rettificati.

On request FKM oil seals.
A richiesta anelli di tenuta FKM.

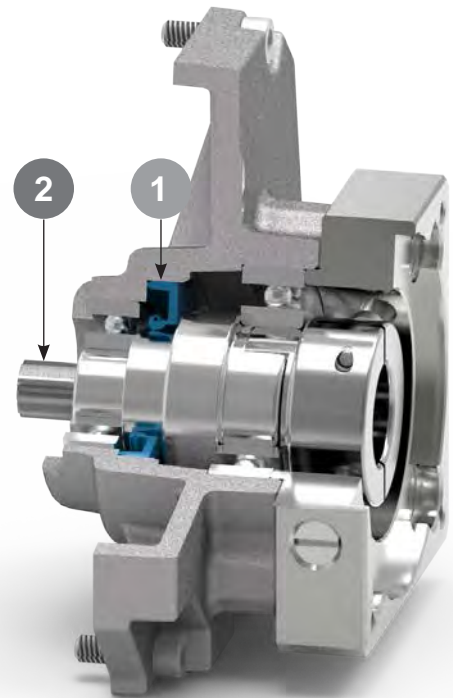

All couplings on stock.
Giunti disponibili a magazzino.



Flanges available for quantity.
Drawings available to download on the web site for a quick production of small quantity.
Flange disponibili per quantità.
Disegni scaricabili dal sito web per una rapida produzione di piccole quantità.

BRUSHLESS FLANGES FOR



Rightangle-Gear

Worm gearboxes
Riduttori a vite senza fine

Page **B-1**



Square-Gear

Square worm gearboxes
Riduttori a vite senza fine quadrati

Page **B-2**



Square-Gear

Square worm gearboxes
Riduttori a vite senza fine quadrati

Page **B-3**



Coaxial-Gear

Aluminum in-line gearboxes
Riduttori coassiali in alluminio

Page **B-4**



Compact-Gear

Aluminum shaft mounted gearboxes
Riduttori ad assi paralleli in alluminio

Page **B-5**



Compact-Gear

Cast iron shaft mounted gearboxes
Riduttori ad assi paralleli in ghisa

Page **B-6**



Cube-Gear

Parallel shaft gearboxes
Riduttori ad assi paralleli

Page **B-7**



Angletech-Gear

Aluminum Helical bevel gearboxes
Riduttori a coppia conica in alluminio

Page **B-8**



Angletech-Gear

Cast Iron Helical bevel gearboxes
Riduttori a coppia conica in ghisa

Page **B-9**



Available kit

Reduction bushing, coupling, flanges.
Bussola di riduzione, giunto, flange.

Page **B-10**



Important notes of selection

Page **B11÷B13**



Instructions

Instructions for assembly of motor
Istruzioni per il montaggio del motore

Page **B15, B16**

WORM GEARBOXES

Flanges for servomotors - Flange per servomotori

Rightangle-Gear

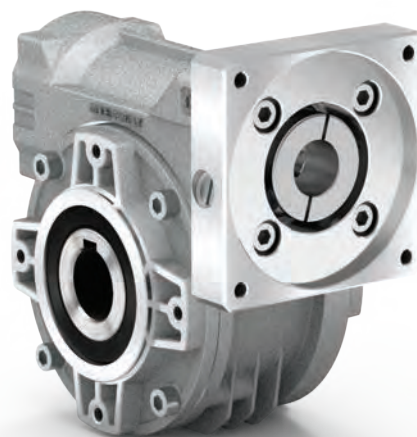
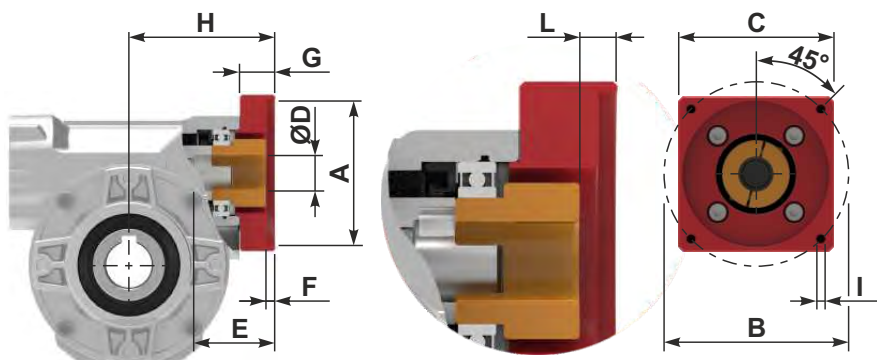

Type	Catalog Flange Code	Input Flanges Kit Code	Bushing Kit Code	Coupling Kit Code	Motor shaft Ø	A	B	C	ØD	E	F	G	L	I	H
030 21Nm	BA	K0304071	KBR09/14G	K0305190L	Ø9	40	63	58	Ø14	30	4	20	4.7	M5x12	68
	BC	K0304072	KBR11/14G	K0305190L	Ø11	60	75	70	Ø14	30	4.5	20	4.7	M5x12	68
	BB	K0304073	-	K0305190L	Ø14	50	70	60	Ø14	32	4.5	28.5	13.2	M5x12	76.5
045 41Nm	BC	K0504072	KBR11/14G	KC355190L	Ø11	60	75	70	Ø14	44	4.5	23	9	M5x12	79
	BB	K0504073	-	KC355190L	Ø14	50	70	70	Ø14	44	4.5	23	9	M5x12	79
	BE	K0504074	-	KC355190L	Ø14	80	100	85	Ø14	44	4.5	23	9	M6x12	79
	BB	K0504075	-	KC355190L	Ø14	95	115	100	Ø14	44	4.5	23	9	M8x12	79
	BE	K0504078	-	KC355190L	Ø14	70	90	80	Ø14	44	4.5	23	9	M6x12	79
050 72Nm	BC	K0504072	KBR11/19G	K0505190L	Ø11	60	75	70	Ø19	48	4.5	23	9	M5x12	83.5
	BC	K0504072	KBR14/19G	K0505190L	Ø14	60	75	70	Ø19	48	4.5	23	9	M5x12	83.5
	BB	K0504073	KBR14/19G	K0505190L	Ø14	50	70	70	Ø19	48	4.5	23	9	M5x12	83.5
	BE	K0504074	KBR14/19G	K0505190L	Ø14	80	100	85	Ø19	48	4.5	23	9	M6x12	83.5
	BF	K0504075	-	K0505190L	Ø19	95	115	100	Ø19	48	4.5	23	9	M8x12	83.5
	BD	K0504078	-	K0505190L	Ø19	70	90	80	Ø19	48	4.5	23	9	M6x12	83.5
063 147Nm	BC	K0634072	KBR14/22G	KC405190L	Ø14	60	75	90	Ø22	58	4.5	25	9	M5x12	104.5
	BB	K0634073	KBR14/22G	KC405190L	Ø14	50	70	80	Ø22	58	4.5	25	9	M5x12	104.5
	BE	K0634074	KBR14/22G	KC405190L	Ø14	80	100	85	Ø22	58	4.5	25	9	M6x12	104.5
63A 191Nm	BF	K0634075	KBR19/22G	KC405190L	Ø19	95	115	100	Ø22	58	4.5	25	9	M8x12	104.5
	BG	K0634076	-	KC405190L	Ø22	110	145	130	Ø22	63	8	30	14	M8x14	109.5
	BD	K0634078	KBR19/22G	KC405190L	Ø19	70	90	90	Ø22	58	4.5	25	9	M6x12	104.5
085 347Nm	BF	K0854075	KBR19/24G	KC505190L	Ø19	95	115	100	Ø24	60	4.5	26	9.5	M8x14	124.5
	BG	K0854076	KBR22/24G	KC505190L	Ø22	110	145	130	Ø24	64	8	30	13.5	M8x14	128.5
	BH	K0854077	-	KC505190L	Ø24	130	165	140	Ø24	60	5	26	9.5	M8x14	124.5
	BD	K0854078	KBR19/24G	KC505190L	Ø19	70	90	95	Ø24	60	4.5	26	9.5	M6x14	124.5



Supplied with reduction bushing
Fornito con bussola di riduzione

Coupling / Giunto

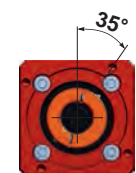

K0504072
Fixing holes shifted by 35°
Fori fissaggio motore ruotati a 35°

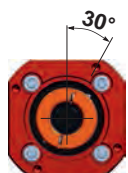

K0504073
K0634078
Fixing holes shifted by 30°
Fori fissaggio motore ruotati a 30°

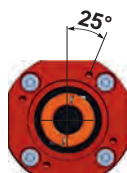

K0634072
K0634073
Fixing holes shifted by 25°
Fori fissaggio motore ruotati a 25°

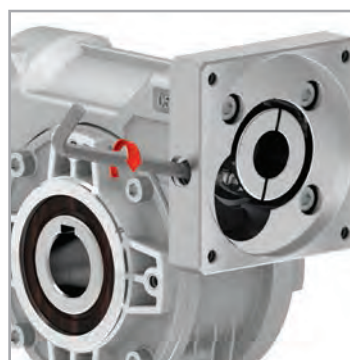

Coupling tightening
Serraggio del giunto

WORM GEARBOXES

Flanges for servomotors - Flange per servomotori

M-Square-Gear

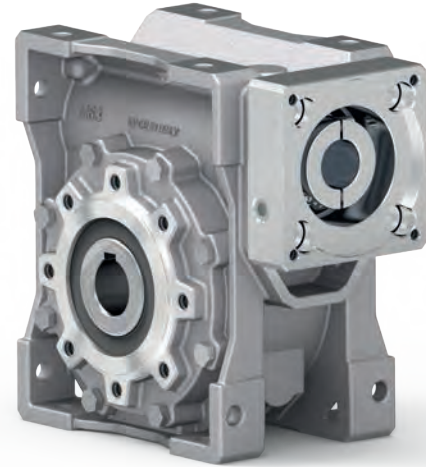
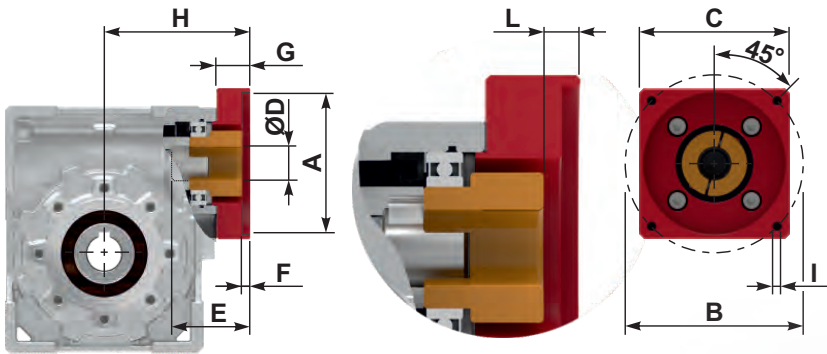

Type	Catalog Flange Code	Input Flanges Kit Code	Bushing Kit Code	Coupling Kit Code	Motor shaft Ø	A	B	C	ØD	E	F	G	L	I	H
M30 21Nm	BA	K0304071	KBR09/14G	K0305190L	Ø9	40	63	58	Ø14	30	4	20	4.7	M5x12	68
	BC	K0304072	KBR11/14G	K0305190L	Ø11	60	75	70	Ø14	30	4.5	20	4.7	M5x12	68
	BB	K0304073	-	K0305190L	Ø14	50	70	60	Ø14	32	4.5	28.5	13.2	M5x12	76.5
M45 41Nm	BC	K0504072	KBR11/14G	KC355190L	Ø11	60	75	70	Ø14	44	4.5	23	9	M5x12	85
	BB	K0504073	-	KC355190L	Ø14	50	70	70	Ø14	44	4.5	23	9	M5x12	85
	BE	K0504074	-	KC355190L	Ø14	80	100	85	Ø14	44	4.5	23	9	M6x12	85
	BF	K0504075	-	KC355190L	Ø14	95	115	100	Ø14	44	4.5	23	9	M8x12	85
	BD	K0504078	-	KC355190L	Ø14	70	90	80	Ø14	44	4.5	23	9	M6x12	85
M50 72Nm	BC	K0504072	KBR11/19G	K0505190L	Ø11	60	75	70	Ø19	48	4.5	23	9	M5x12	88.5
	BC	K0504072	KBR14/19G	K0505190L	Ø14	60	75	70	Ø19	48	4.5	23	9	M5x12	88.5
	BB	K0504073	KBR14/19G	K0505190L	Ø14	50	70	70	Ø19	48	4.5	23	9	M5x12	88.5
	BE	K0504074	KBR14/19G	K0505190L	Ø14	80	100	85	Ø19	48	4.5	23	9	M6x12	88.5
	BF	K0504075	-	K0505190L	Ø19	95	115	100	Ø19	48	4.5	23	9	M8x12	88.5
M63 147Nm	BD	K0504078	-	K0505190L	Ø19	70	90	80	Ø19	48	4.5	23	9	M6x12	88.5
	BC	K0634072	KBR14/22G	KC405190L	Ø14	60	75	90	Ø22	58	4.5	25	9	M5x12	105.5
	BB	K0634073	KBR14/22G	KC405190L	Ø14	50	70	80	Ø22	58	4.5	25	9	M5x12	105.5
	BE	K0634074	KBR14/22G	KC405190L	Ø14	80	100	85	Ø22	58	4.5	25	9	M6x12	105.5
	BF	K0634075	KBR19/22G	KC405190L	Ø19	95	115	100	Ø22	58	4.5	25	9	M8x12	105.5
M75 270Nm	BG	K0634076	-	KC405190L	Ø22	110	145	130	Ø22	63	8	30	14	M8x14	105.5
	BD	K0634078	KBR19/22G	KC405190L	Ø19	70	90	90	Ø22	58	4.5	25	9	M6x12	105.5
	BF	K0854075	KBR19/24G	KC505190L	Ø19	95	115	100	Ø24	60	4.5	26	9.5	M8x14	122
	BG	K0854076	KBR22/24G	KC505190L	Ø22	110	145	130	Ø24	64	8	30	13.5	M8x14	126
M85 347Nm	BH	K0854077	-	KC505190L	Ø24	130	165	140	Ø24	60	5	26	9.5	M8x14	122
	BD	K0854078	KBR19/24G	KC505190L	Ø19	70	90	95	Ø24	60	4.5	26	9.5	M6x14	122
	BF	K0854075	KBR19/24G	KC505190L	Ø19	95	115	100	Ø24	60	4.5	26	9.5	M8x14	124.5
	BG	K0854076	KBR22/24G	KC505190L	Ø22	110	145	130	Ø24	64	8	30	13.5	M8x14	128.5

Supplied with reduction bushing
Fornito con bussola di riduzione



Coupling / Giunto

Coupling
Giunto

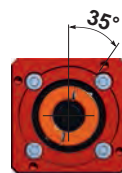

K0504072
Fixing holes shifted by 35°
Fori fissaggio motore ruotati a 35°

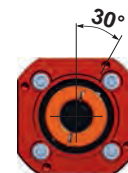

K0504073
K0634078
Fixing holes shifted by 30°
Fori fissaggio motore ruotati a 30°

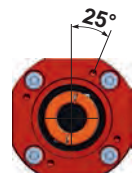

K0634072
K0634073
Fixing holes shifted by 25°
Fori fissaggio motore ruotati a 25°

WORM GEARBOXES

Flanges for servomotors - Flange per servomotori

Q-Square-Gear

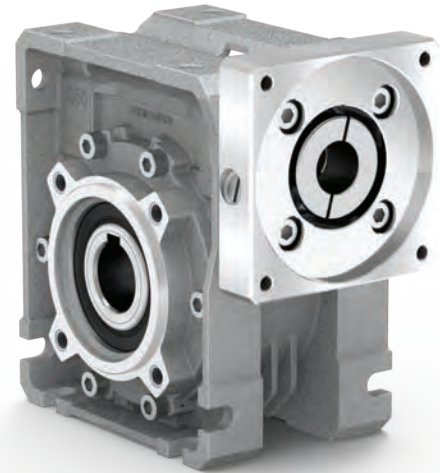
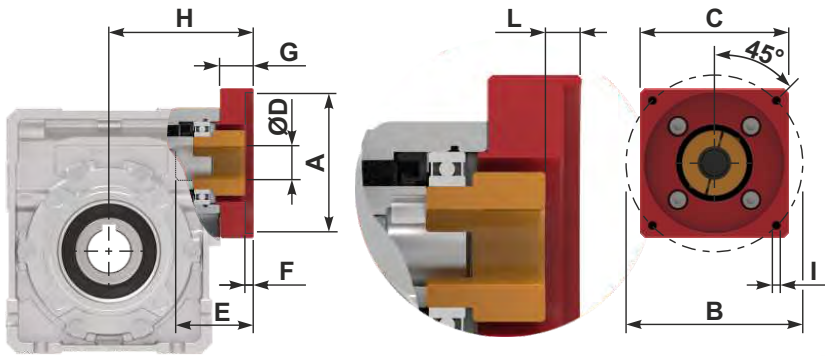

Type	Catalog Flange Code	Input Flanges Kit Code	Input Flanges Kit Code	Bushing Kit Code	Coupling Kit Code	Motor shaft Ø	A	B	C	ØD	E	F	G	L	I	H
Q63 147Nm	BC	K0634072	K0634072	KBR14/22G	KC405190L	Ø14	60	75	90	Ø22	58	4.5	25	9	M5x12	104.5
	BB	K0634073	K0634073	KBR14/22G	KC405190L	Ø14	50	70	80	Ø22	58	4.5	25	9	M5x12	104.5
	BE	K0634074	K0634074	KBR14/22G	KC405190L	Ø14	80	100	85	Ø22	58	4.5	25	9	M6x12	104.5
	BF	K0634075	K0634075	KBR19/22G	KC405190L	Ø19	95	115	100	Ø22	58	4.5	25	9	M8x12	104.5
	BG	K0634076	K0634076	-	KC405190L	Ø22	110	145	130	Ø22	63	8	30	14	M8x14	109.5
Q75 270Nm	BD	K0634078	K0634078	KBR19/22G	KC405190L	Ø19	70	90	90	Ø22	58	4.5	25	9	M6x12	104.5
	BF	K0854075	K0854075	KBR19/24G	KC505190L	Ø19	95	115	100	Ø24	60	4.5	26	9.5	M8x14	122
	BG	K0854076	K0854076	KBR22/24G	KC505190L	Ø22	110	145	130	Ø24	64	8	30	13.5	M8x14	126
	BH	K0854077	K0854077	-	KC505190L	Ø24	130	165	140	Ø24	60	5	26	9.5	M8x14	122
Q85 347Nm	BD	K0854078	K0854078	KBR19/24G	KC505190L	Ø19	70	90	95	Ø24	60	4.5	26	9.5	M6x14	124.5
	BF	K0854075	K0854075	KBR19/24G	KC505190L	Ø19	95	115	100	Ø24	60	4.5	26	9.5	M8x14	124.5
	BG	K0854076	K0854076	KBR22/24G	KC505190L	Ø22	110	145	130	Ø24	64	8	30	13.5	M8x14	128.5
	BH	K0854077	K0854077	-	KC505190L	Ø24	130	165	140	Ø24	60	5	26	9.5	M8x14	124.5

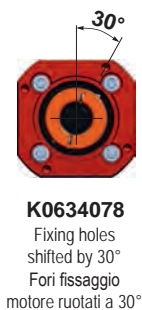

COAXIAL GEARBOXES

Flanges for servomotors - Flange per servomotori

Aluminum Coaxial-Gear

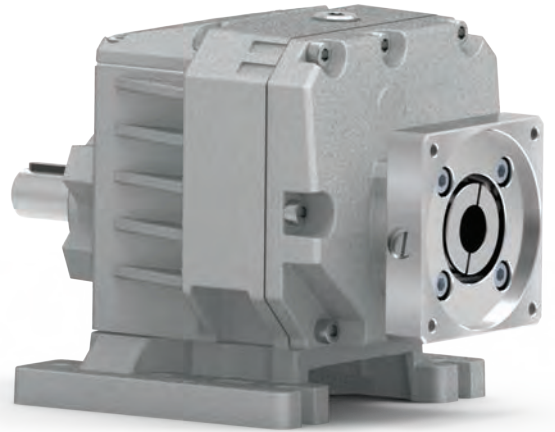
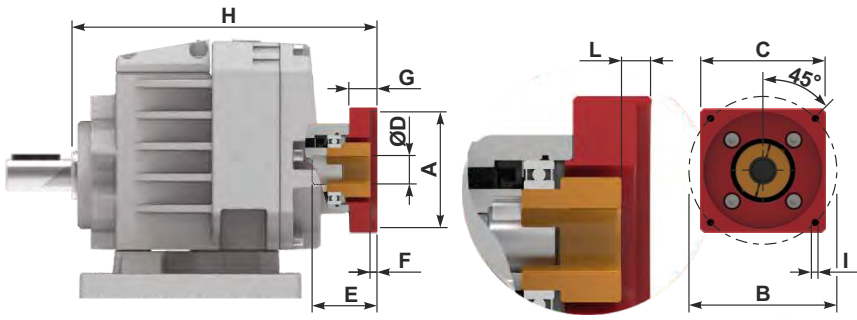

Type	Catalog Flange Code	Input Flanges Kit Code	Bushing Kit Code	Coupling Kit Code	Motor shaft Ø	A	B	C	ØD	E	F	G	L	I	H		
413A 175Nm	BC	K0504072	KBR11/14G	KC355190L	Ø11	60	75	70	Ø14	38	4.5	23	9	M5x12	190.5		
	BC	K0504072	-	KC355190L	Ø14	60	75	70	Ø14	38	4.5	23	9	M5x12	190.5		
	BB	K0504073	-	KC355190L	Ø14	50	70	70	Ø14	38	4.5	23	9	M5x12	190.5		
	BE	K0504074	-	KC355190L	Ø14	80	100	85	Ø14	38	4.5	23	9	M6x12	190.5		
	BB	K0504073	-	KC355190L	Ø14	50	70	70	Ø14	38	4.5	23	9	M5x12	190.5		
	BE	K0504074	-	KC355190L	Ø14	80	100	85	Ø14	38	4.5	23	9	M6x12	190.5		
412A 175Nm	BC	K0634072	KBR14/22G	KC405190L	Ø14	60	75	90	Ø22	55.5	4.5	25	9	M5x12	186.5	243	260
	BB	K0634073	KBR14/22G	KC405190L	Ø14	50	70	80	Ø22	55.5	4.5	25	9	M5x12	186.5	243	260
513A 360Nm	BE	K0634074	KBR14/22G	KC405190L	Ø14	80	100	85	Ø22	55.5	4.5	25	9	M6x12	186.5	243	260
	BF	K0634075	KBR19/22G	KC405190L	Ø19	95	115	100	Ø22	55.5	4.5	25	9	M8x12	186.5	243	260
613A 530Nm	BG	K0634076	-	KC405190L	Ø22	110	145	130	Ø22	60.5	8	30	14	M8x14	191.5	248	265
	BD	K0634078	KBR19/22G	KC405190L	Ø19	70	90	90	Ø22	55.5	4.5	25	9	M6x12	186.5	243	260
512A 360Nm	BF	K0854075	KBR19/24G	KC505190L	Ø19	95	115	100	Ø24	58	4.5	26	9.5	M8x14	235.5	252	
	BG	K0854076	KBR22/24G	KC505190L	Ø22	110	145	130	Ø24	62	8	30	13.5	M8x14	239.5	256	
612A 530Nm	BH	K0854077	-	KC505190L	Ø24	130	165	140	Ø24	58	5	26	9.5	M8x14	235.5	252	
	BD	K0854078	KBR19/24G	KC505190L	Ø19	70	90	95	Ø24	58	4.5	26	9.5	M6x14	235.5	252	

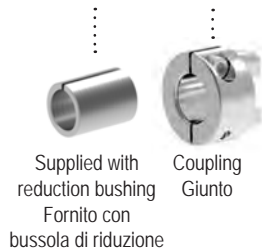

Flanges for servomotors
Flange per servomotori

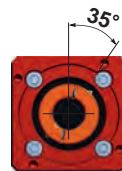

K0504072
Fixing holes shifted by 35°
Fori fissaggio motore ruotati a 35°

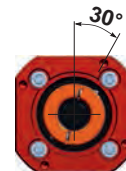

K0634078
Fixing holes shifted by 30°
Fori fissaggio motore ruotati a 30°

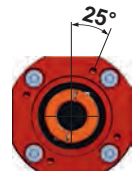

K0634073
Fixing holes shifted by 25°
Fori fissaggio motore ruotati a 25°

SHAFT MOUNTED GEARBOXES

Flanges for servomotors - Flange per servomotori

Aluminum Compact-Gear

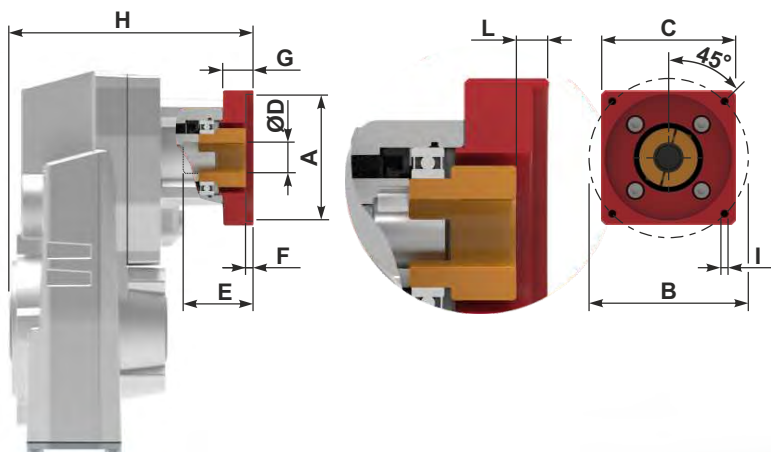

Type	Catalog Flange Code	Input Flanges Kit Code	Bushing Kit Code	Coupling Kit Code	Motor shaft Ø	A	B	C	ØD	E	F	G	L	I	H		
															FA33	FA43	
FA33 150Nm	BC	K0504072	KBR11/14G	KC355190L	Ø11	60	75	70	Ø14	38	4.5	23	9	M5x12	180	180	
	BC	K0504072	-	KC355190L	Ø14	60	75	70	Ø14	38	4.5	23	9	M5x12	180	180	
FA43 320Nm	BB	K0504073	-	KC355190L	Ø14	50	70	70	Ø14	38	4.5	23	9	M5x12	180	180	
	BE	K0504074	-	KC355190L	Ø14	80	100	85	Ø14	38	4.5	23	9	M6x12	180	180	
FA32 150Nm	BC	K0634072	KBR14/22G	KC405190L	Ø14	60	75	90	Ø22	55.5	4.5	25	9	M5x12	174.5	174.5	244
	BB	K0634073	KBR14/22G	KC405190L	Ø14	50	70	80	Ø22	55.5	4.5	25	9	M5x12	174.5	174.5	244
FA42 320Nm	BE	K0634074	KBR14/22G	KC405190L	Ø14	80	100	85	Ø22	55.5	4.5	25	9	M6x12	174.5	174.5	244
	BF	K0634075	KBR19/22G	KC405190L	Ø19	95	115	100	Ø22	55.5	4.5	25	9	M8x12	174.5	174.5	244
FA53 490Nm	BG	K0634076	-	KC405190L	Ø22	110	145	130	Ø22	60.5	8	30	14	M8x14	179.5	179.5	249
	BD	K0634078	KBR19/22G	KC405190L	Ø19	70	90	90	Ø22	55.5	4.5	25	9	M6x12	174.5	174.5	244
FA52 490Nm	BF	K0854075	KBR19/24G	KC505190L	Ø19	95	115	100	Ø24	58	4.5	26	9.5	M8x14	FA52 235		
	BG	K0854076	KBR22/24G	KC505190L	Ø22	110	145	130	Ø24	62	8	30	13.5	M8x14	239		
	BH	K0854077	-	KC505190L	Ø24	130	165	140	Ø24	58	5	26	9.5	M8x14	235		
	BD	K0854078	KBR19/24G	KC505190L	Ø19	70	90	95	Ø24	58	4.5	26	9.5	M6x14	235		

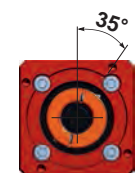
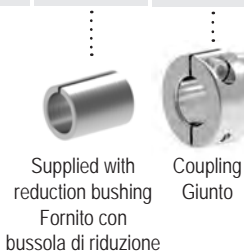

K0504072
Fixing holes shifted by 35°
Fori fissaggio motore ruotati a 35°

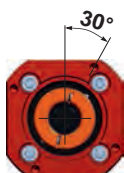

K0504073
K0634078
Fixing holes shifted by 30°
Fori fissaggio motore ruotati a 30°

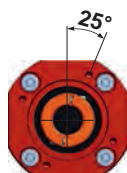

K0634072
K0634073
Fixing holes shifted by 25°
Fori fissaggio motore ruotati a 25°

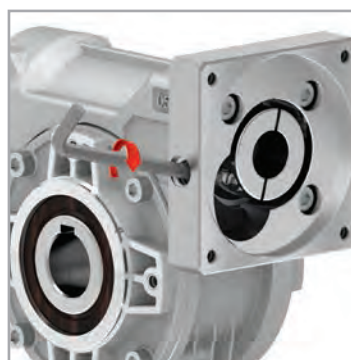

Coupling tightening
Serraggio del giunto

SHAFT MOUNTED GEARBOXES

Flanges for servomotors - Flange per servomotori

Cast Iron Compact-Gear

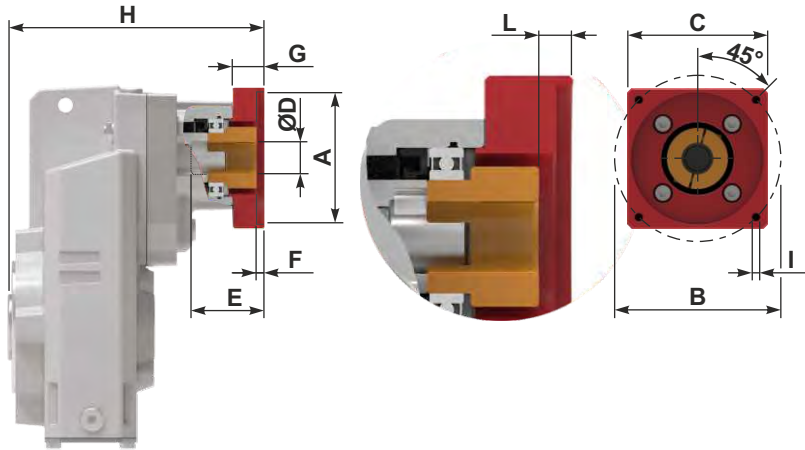

Type	Catalog Flange Code	Input Flanges Kit Code	Bushing Kit Code	Coupling Kit Code	Motor shaft Ø	A	B	C	ØD	E	F	G	L	I	H	
															FC63	FC73
FC63 675Nm	BC	K0634072	KBR14/22G	KC405190L	Ø14	60	75	90	Ø22	51.5	4.5	25	9	M5x12	244	255.5
	BB	K0634073	KBR14/22G	KC405190L	Ø14	50	70	80	Ø22	51.5	4.5	25	9	M5x12	244	255.5
	BE	K0634074	KBR14/22G	KC405190L	Ø14	80	100	85	Ø22	51.5	4.5	25	9	M6x12	244	255.5
FC73 900Nm	BF	K0634075	KBR19/22G	KC405190L	Ø19	95	115	100	Ø22	51.5	4.5	25	9	M8x12	244	255.5
	BG	K0634076	-	KC405190L	Ø22	110	145	130	Ø22	56.5	8	30	14	M8x14	249	260.5
	BD	K0634078	KBR19/22G	KC405190L	Ø19	70	90	90	Ø22	51.5	4.5	25	9	M6x12	244	255.5
FC62 675Nm	BF	K0854075	KBR19/24G	KC505190L	Ø19	95	115	100	Ø24	54	4.5	26	9.5	M8x14	235	246.5
	BG	K0854076	KBR22/24G	KC505190L	Ø22	110	145	130	Ø24	58	8	30	13.5	M8x14	239	251.5
FC72 900Nm	BH	K0854077	-	KC505190L	Ø24	130	165	140	Ø24	54	5	26	9.5	M8x14	235	246.5
	BD	K0854078	KBR19/24G	KC505190L	Ø19	70	90	95	Ø24	54	4.5	26	9.5	M6x14	235	246.5

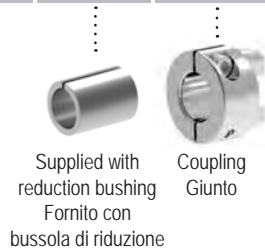

Reduction Bushing
Bussola di riduzione

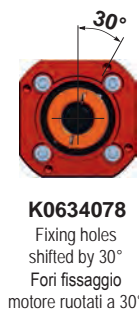

PARALLEL SHAFT GEARBOXES

Flanges for servomotors - Flange per servomotori

Cast Iron Cube-Gear

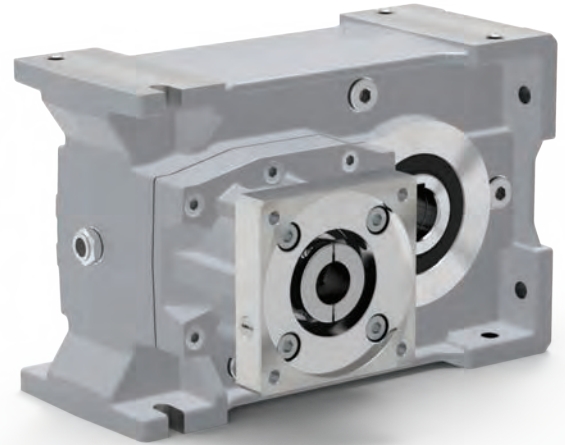
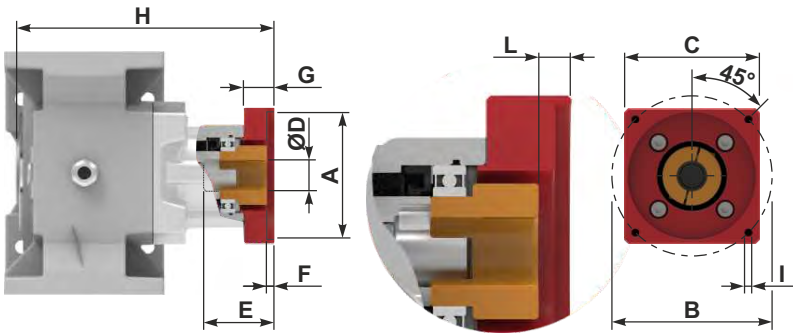

Type	Catalog Flange Code	Input Flanges Kit Code	Bushing Kit Code	Coupling Kit Code	Motor shaft Ø	A	B	C	ØD	E	F	G	L	I	H	
						H63C	H73C									
H63C 675Nm	BC	K0634072	KBR14/22G	KC405190L	Ø14	60	75	90	Ø22	55.5	4.5	25	9	M5x12	244	255.5
	BB	K0634073	KBR14/22G	KC405190L	Ø14	50	70	80	Ø22	55.5	4.5	25	9	M5x12	244	255.5
	BE	K0634074	KBR14/22G	KC405190L	Ø14	80	100	85	Ø22	55.5	4.5	25	9	M6x12	244	255.5
H73C 900Nm	BF	K0634075	KBR19/22G	KC405190L	Ø19	95	115	100	Ø22	55.5	4.5	25	9	M8x12	244	255.5
	BG	K0634076	-	KC405190L	Ø22	110	145	130	Ø22	60.5	8	30	14	M8x14	249	260.5
	BD	K0634078	KBR19/22G	KC405190L	Ø19	70	90	90	Ø22	55.5	4.5	25	9	M6x12	244	255.5
H62C 675Nm	BF	K0854075	KBR19/24G	KC505190L	Ø19	95	115	100	Ø24	58	4.5	26	22	M8x14	235	246.5
	BG	K0854076	KBR22/24G	KC505190L	Ø22	110	145	130	Ø24	62	8	30	26	M8x14	239	250.5
H72C 900Nm	BH	K0854077	-	KC505190L	Ø24	130	165	140	Ø24	58	5	26	22	M8x14	235	246.5
	BD	K0854078	KBR19/24G	KC505190L	Ø19	70	90	95	Ø24	58	4.5	26	22	M6x14	235	246.5

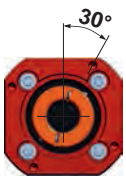

K0634078
Fixing holes shifted by 30°
Fori fissaggio motore ruotati a 30°

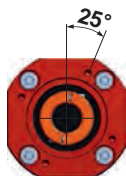

K0634072
K0634073
Fixing holes shifted by 25°
Fori fissaggio motore ruotati a 25°



Flanges for servomotors
Flange per servomotori

HELICAL BEVEL GEARBOXES

Flanges for servomotors - Flange per servomotori

Cast Iron Angletech-Gear

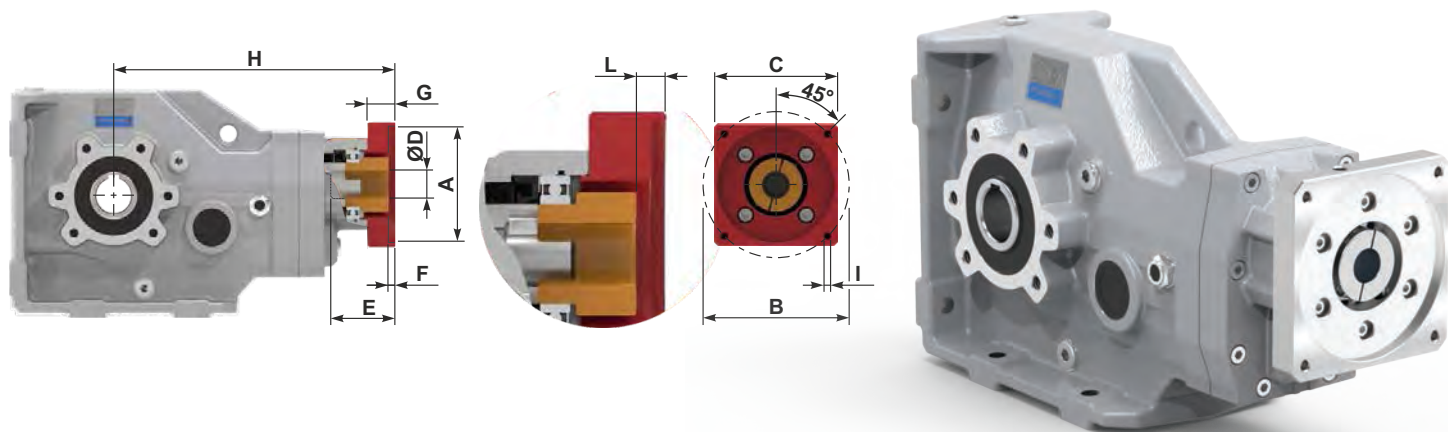

Type	Catalog Flange Code	Input Flanges Kit Code	Bushing Kit Code	Coupling Kit Code	Motor shaft Ø	A	B	C	ØD	E	F	G	L	I	H			
						X74C	X84C	114C	134C									
X74C 100Nm	BC	K0634072	KBR14/22G	KC405190L	Ø14	60	75	90	Ø22	55.5	4.5	25	9	M5x12	316	333	257.5	268
X84C 160Nm	BB	K0634073	KBR14/22G	KC405190L	Ø14	50	70	80	Ø22	55.5	4.5	25	9	M6x12	316	333	257.5	268
114C 250Nm	BE	K0634074	KBR14/22G	KC405190L	Ø14	80	100	85	Ø22	55.5	4.5	25	9	M6x12	316	333	257.5	268
134C 410Nm	BF	K0634075	KBR19/22G	KC405190L	Ø19	95	115	100	Ø22	55.5	4.5	25	9	M8x12	316	333	257.5	268
	BG	K0634076	-	KC405190L	Ø22	110	145	130	Ø22	60.5	8	30	14	M8x14	321	338	262.5	273
	BD	K0634078	KBR19/22G	KC405190L	Ø19	70	90	90	Ø22	55.5	4.5	25	9	M6x12	316	333	257.5	268
															X73C	X83C	113C	133C
X73C 90Nm	BF	K0854075	KBR19/24G	KC505190L	Ø19	95	115	100	Ø24	58	4.5	26	9.5	M8x14	307	324	244.5	259
X83C 150Nm	BG	K0854076	KBR22/24G	KC505190L	Ø22	110	145	130	Ø24	62	8	30	13.5	M8x14	311	328	248.5	263
113C 250Nm	BH	K0854077	-	KC505190L	Ø24	130	165	140	Ø24	58	5	26	9.5	M8x14	307	324	248.5	259
133C 410Nm	BD	K0854078	KBR19/24G	KC505190L	Ø19	70	90	95	Ø24	58	5	26	9.5	M6x14	307	324	248.5	259

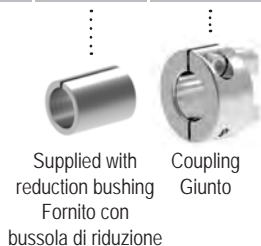

Coupling
Giunto

Available kits

Kit disponibili

Reduction bushings

Bussole di riduzione

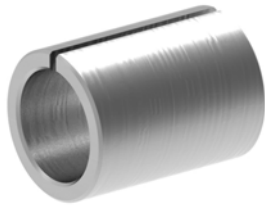

Reduction bushing dimensions

Dimensioni bussola di riduzione

ØI	ØE	Code
Ø9	Ø14	KBR09/14G
Ø11	Ø14	KBR11/14G
Ø11	Ø19	KBR11/19G
Ø14	Ø19	KBR14/19G
Ø14	Ø22	KBR14/22G
Ø19	Ø22	KBR19/22G
Ø19	Ø24	KBR19/24G
Ø22	Ø24	KBR22/24G

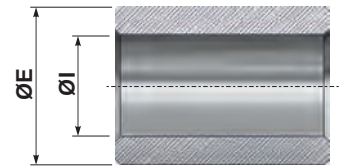

Couplings

Giunti



Coupling dimensions

Dimensioni giunto

Ød	ØD (min)	Code
Ø9	Ø34	K0305190L
Ø14	Ø40	KC355190L
Ø19	Ø42	K0505190L
Ø22	Ø48	KC405190L
Ø24	Ø57	KC505190L

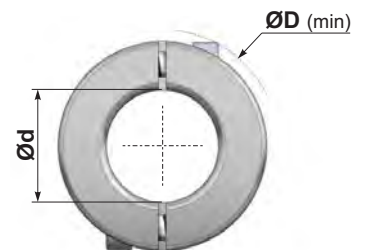

Flanges for servomotor

Flange per servomotore



Flange dimensions

Dimensioni flangia

Code Kit flange	A	B	C
K0304071	40	63	58
K0304072	60	75	70
K0304073	50	70	60
K0504072	60	75	70
K0504073	50	70	70
K0504074	80	100	85
K0504075	95	115	100
K0504078	70	90	80
K0634072	60	75	90
K0634073	50	70	80
K0634074	80	100	85
K0634075	95	115	100
K0634076	110	145	130
K0634078	70	90	90
K0854075	95	115	100
K0854076	110	145	130
K0854077	130	165	140
K0854078	70	90	95

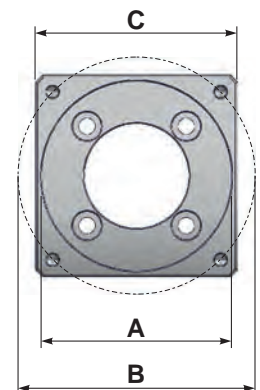

BRUSHLESS-TECH



Flange for servomotor
Flange per servomotore



Coupling
Giunto



Reduction bushing
Bussola di riduzione



HYDRO • MEC

X3S HIGH EFFICIENCY GEARBOXES

Several factors should be considered before selecting the appropriate gearbox for :

Diversi fattori devono essere considerati prima di selezionare il riduttore appropriato per:

1 motor speeds from 0 to 1500 rpm, you can use the rating in our Hydro-Mec general catalog. Velocità del motore da 0 a 1500 giri/min, vedere la selezione nel nostro catalogo generale Hydro-Mec.

2 Applications having frequent starts and stops. Applicazioni con avviamenti e arresti frequenti.

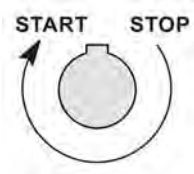

3 Quick inversion of rotation. Veloci inversioni di rotazione.

030 Rightangle - Gear 21Nm Rating - Aluminum WORM GEARBOXES													
1 QUICK SELECTION / Selezione veloce													
Output Speed n_2 [min ⁻¹]	Ratio i	Motor power P_m [kW]	Output torque M_{2m} [Nm]	Service factor f.s.	Nominal power P_n [kW]	Nominal torque M_{2n} [Nm]	Available B5 motor flanges		Available B14 motor flanges		Dynamic efficiency RD	Tooth Module [mm]	Ratios code
							-A	-B	-O	-P			
280	5	0.18	5	3.3	0.60	17	B		B-C		82	1.26	09
200	7	0.18	7	2.4	0.44	17	B		B-C		80	1.44	01
140	10	0.18	10	1.8	0.32	17	B		B-C		78	1.44	02
93	15	0.18	13	1.4	0.25	19	B		B-C		73	1.44	03
70	20	0.18	17	1.1	0.20	19	B		B-C		70	1.09	04
47	30	0.12	15	1.4	0.17	21	B		B-C		62	1.44	05
35	40	0.12	19	1.1	0.13	20	B		B-C		57	1.09	06
23	61	0.09	19	1.1	0.10	20	B		B-C		50	0.72	07
17.5	80	0.06	16	1.0	0.06	16	B		B-C		48	0.56	08
14	100	0.06*	16	0.5	0.03	8	B		B-C		40	0.45	10

■ Motor Flanges Available Flange Motore disponibili
 □ B) Supplied with Reduction Bushing (Disponibile a richiesta senza riduzione di riduzione)
 ■ Available on Request without reduction bushing (Disponibile a richiesta senza riduzione di riduzione)
 * Power higher than the maximum one which can be supported by the gearbox. Select according to the torque M_{2n} .
 Potenza superiore a quella massima sopportabile dal riduttore. Selezionare in base al momento torcente M_{2n} .

EN Unit 030 is supplied with synthetic oil, providing "long life" lubrication. For mounting position V5-V6 please contact us. See table 1 for lubrication and recommended quantity.

• LUBRICATION 030 Oil Quantity 0.03 Lt.
 SHELL Omala S4 WE 320 ENI Tellum VSF 320

For all details on lubrication and oils, check our website

Service factor - Worm gears / Fattore di servizio - Ingranaggi a vite senza fine

Type of load and starts per hour Tipo di carico e avviamenti per ora	Oper. hours per day Ore di funz. giorn.				
		<2 h	2 ÷ 8 h	8 ÷ 16 h	
Continuous or intermittent appl. with start / hour Applicazione cont. o interm. con n.ro operazioni/ora	Uniform / Uniforme	0.9	1	1.25	
		Moderate / Moderato	1	1.25	1.5
		Heavy / Forte	1.25	1.5	1.75
Intermittent application with start / hour Applicazione intermittente con n.ro operazioni/ora	Uniform / Uniforme	1.25	1.5	1.75	
	Moderate / Moderato	1.5	1.75	2	
	Heavy / Forte	1.75	2	2.25	

Service factor - Gears / Fattore di servizio - Ingranaggi

Type of load and starts per hour Tipo di carico e avviamenti per ora	Oper. hours per day Ore di funz. giorn.			
		3 h	10 h	24 h
Continuous or intermittent appl. with start / hour Applicazione cont. o interm. con n.ro operazioni/ora	Uniform / Uniforme	0.8	1	1.25
	Moderate / Moderato	1	1.25	1.5
	Heavy / Forte	1.25	1.5	1.75
Intermittent application with start / hour Applicazione intermittente con n.ro operazioni/ora	Uniform / Uniforme	1	1.25	1.5
	Moderate / Moderato	1.25	1.5	1.75
	Heavy / Forte	1.5	1.75	2.15

Add a second service factor for:

Aggiungere un secondo fattore di servizio per:

4 Motor speeds from 1500 to 3000 rpm: Consider a reduction of the nominal torque M_{2R} of 20%. Velocità del motore da 1500 a 3000 giri/min: Considerare una riduzione della coppia nominale M_{2R} del 20%.

5 Motor with speeds over 3000rpm please contact us. Velocità del motore oltre 3000 giri/min, contattateci.

Special options on request on the gearbox

Opzioni speciali a richiesta sul riduttore

6 ON REQUEST for speeds above 2000 rpm FKM oil seal are used on coupling configuration. A RICHIESTA per velocità al di sopra di 2000 giri/min in ingresso sul giunto usare anello di tenuta in FKM.

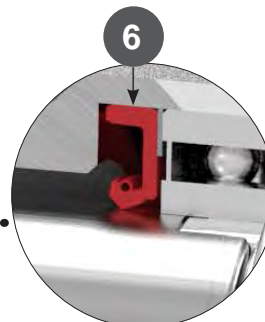

7 With high speed C3 bearings are suggested. Con alte velocità si consigliano cuscinetti con gioco C3.

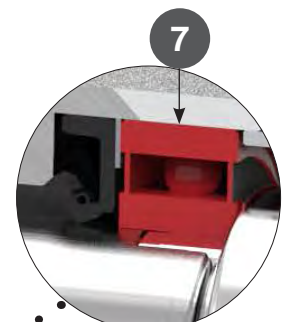

Suggested mounting position are as follows

Le posizioni di montaggio suggerite sono le seguenti

With high input speeds above 2000 rpm Oil breather plugs are suggested as internal pressure can rise. In some critical cases the oil quantity that are indicated in our website on the lubrication pages, may need to reduced. So please contact us.

Con velocità di ingresso elevate superiori a 2000 giri/min si consiglia l'uso di tappi di sfiato olio poiché la pressione interna può aumentare. In alcuni casi critici potrebbe essere necessario ridurre la quantità di olio indicata nel nostro sito relativa alla lubrificazione. Quindi per favore contattaci.

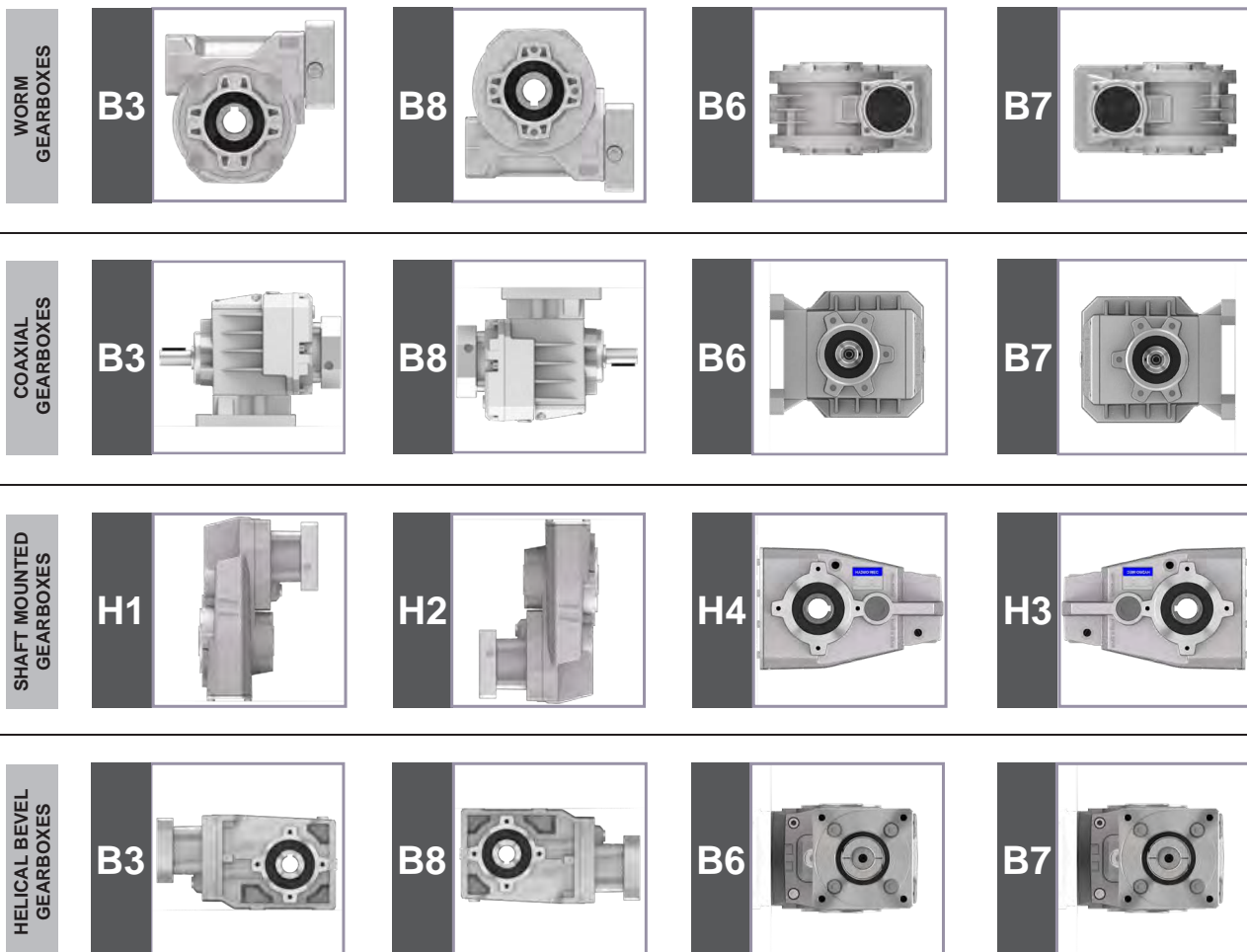

SUGGESTED POSITION

Lubrication for mounting position

Lubrificazione per posizione di montaggio

Vertical positions are critical

Le posizioni verticali sono critiche

These position required 2Z or 2RS bearings.

Queste posizioni richiedono l'utilizzo di cuscinetti 2Z o 2RS.

V6/H6

**MOST
CRITICAL**

Continuous duty with high start and stop is not suggested. In this condition the correct functioning of lower oil seal becomes critical.

Il servizio continuo con avvii e arresti frequenti non è consigliato.

In questa condizione il corretto funzionamento dell'anello di tenuta inferiore diventa critico.

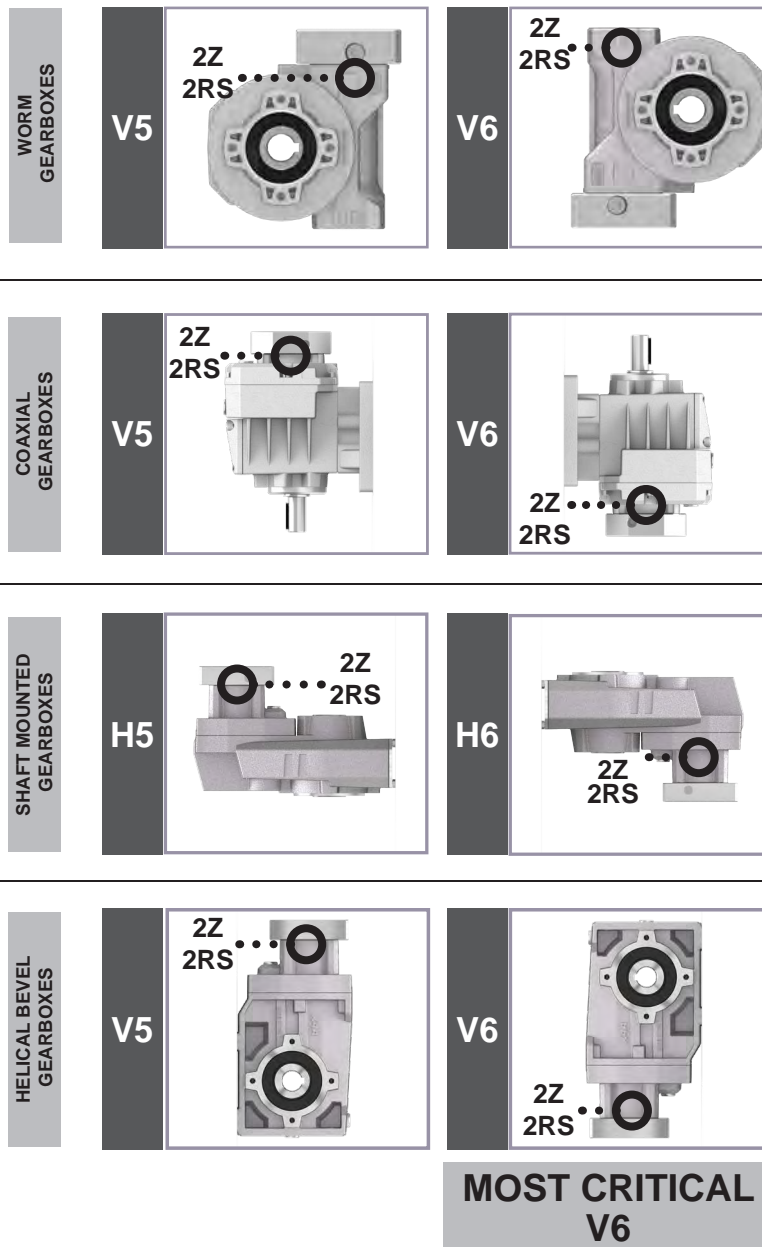

Instructions for motor assembly

Istruzioni per il montaggio del motore

1

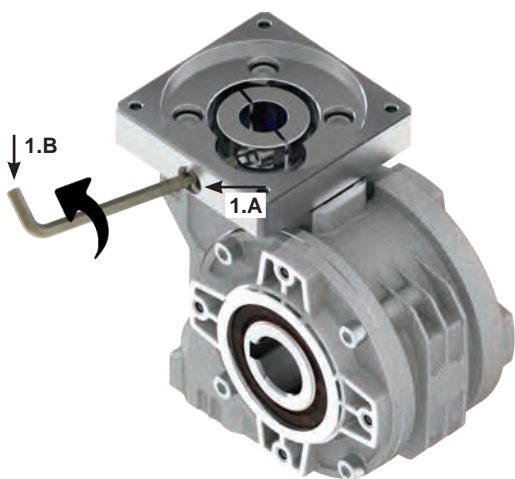

Remove the protection screws on the input flange.

Rimuovere le viti di protezione sulla flangia motore.

1.A



Loosen the fastening screws of the coupling.

Allentare le viti di serraggio del giunto.

1.B



2

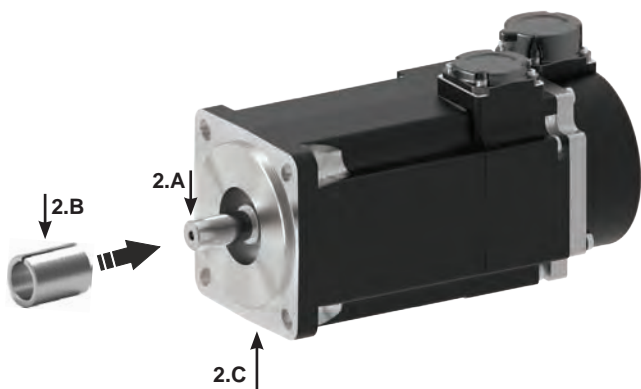

Motor shaft without key.

Albero motore senza linguetta.

CHECK

2.A



Only if used with reduction bushing.

Mount the reduction bushing with the rubber hammer.

2.B

Se prevista la bussola di riduzione. Utilizzare un martello di gomma per il montaggio.



3

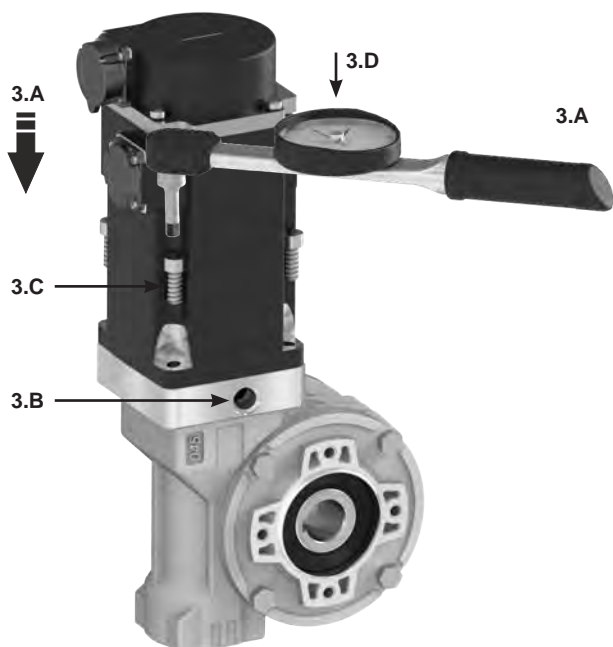

Clean the contact surface on the motor flange and input flange.

Pulire le superfici di contatto della flangia motore e flangia riduttore.

CHECK

2.C



Place the gearbox with the hollow shaft that has to be connected with the motor (input shaft) facing up. The gearbox has to be without load and the output shaft has to be free to rotate.

Posizionare il riduttore con l'albero cavo di accoppiamento al motore (albero entrata) rivolto verso l'alto. Il riduttore non deve essere collegato a nessun carico e l'albero di uscita deve essere libero di ruotare.

CHECK

3.A



Before mounting the motor, check aligned the screw is with the hole on the input motor flange.

Prima di montare il motore, assicurarsi che le viti del giunto sia allineata con il foro sulla flangia riduttore.

CHECK

3.B



For fixing the motor, apply anti-loosening paste on screw thread, employ Arexons 52A70 strong thread lock or similar.

Per il fissaggio del motore, applicare un prodotto anti-svitamento sui filetti delle viti, utilizzare un frena filetto forte tipo Arexons 52A70 o similare.

3.C



Tighten the screws according to table torque values. Recommended the class screws 8.8.

Serrare le viti in base ai valori in tabella. Consigliato le viti di classe 8.8.

3.D

Screw Vite	TS [Nm]
M4	3
M5	6
M6	10
M8	25
M10	45

Instructions for motor assembly

Istruzioni per il montaggio del motore

4

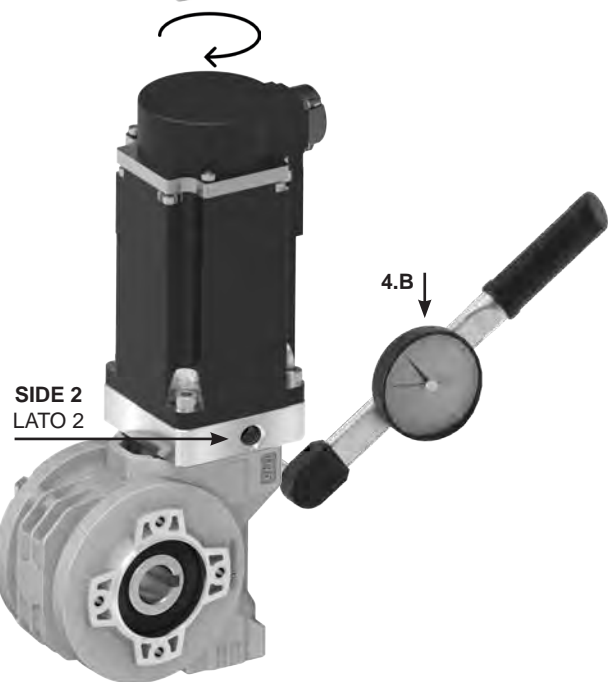
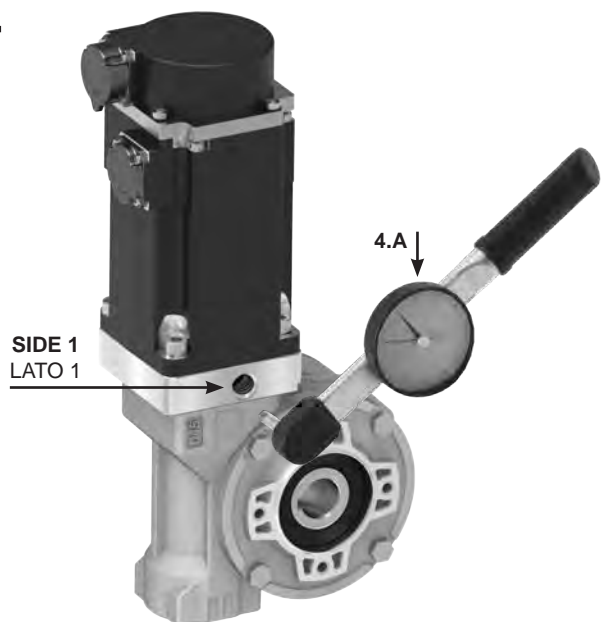

5

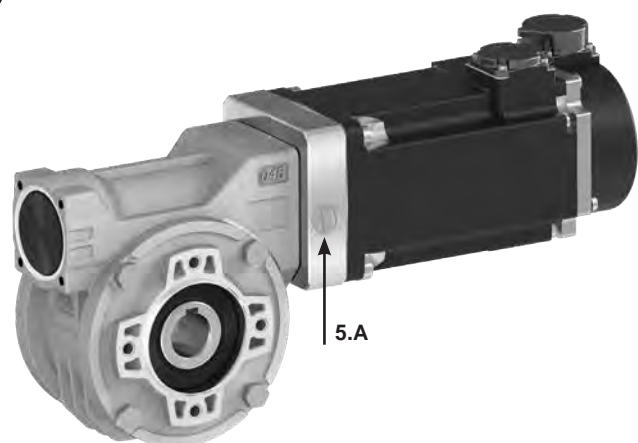

Tighten the screws (SC) according to the torque (TS) reported in the table.

(SC) Socked-head screw (Allen screw), class screws 8.8 .

4.A

Stringere le viti (SC) del giunto in base alla coppia di serraggio (TS) riportata nella tabella.

(SC) Vite a testa cilindrica esagono incassato (Brogola), classe 8.8 .

Coupling kit code	SC	TS [Nm]
K0305190L	M4x14	3.5
KC355190L	M4x14	3.5
K0505190L	M5x16	6
KC405190L	M5x16	6
KC505190L	M6x20	10



First tighten on side 1 and side 2, repeat the tightening a second round on both sides.

4.B

Stringere una prima volta sul lato 1 e sul lato 2, ripetere il serraggio una seconda volta su entrambi i lati.



CHECK

Exceeding the torque to fix the locking bolt can damage the coupling.

Il superamento della coppia di serraggio della vite di bloccaggio può danneggiare il dispositivo di accoppiamento



CHECK

5.A

Reset the protection screws.

Riposizionare le viti di protezione.

abaroadrive

HIGH EFFICIENCY GEARBOXES

Larrondo-Beheko Etorbidea, 4-P2
48180 LOIU - BIZKAIA - SPAIN
comercial@abaroadrive.com
T(+34) 946 765 423
www.abaroadrive.com



Distributed from

